



VHT4721



TECHNICAL INFORMATION

Flow (L/min)	21
Flow (US Gpm)	0,246527777777778
Rotation regime (rpm)	1450
Pressure (MPa)	14
Pressure (bar)	140
Pressure (psi)	2030
Power (hp)	7,5
Power (kW)	5,51
Overall dimensions L x l x h (mm)	315,5x254,5x146
Weight (kg)	14,5



Documents

Male shaft (key)

Male shaft (key) - vers. ATEX

Illustration Male shaft (key)

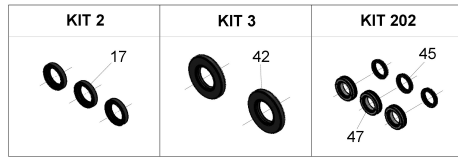

Fissare con Loctite 542 colore ROSSO cod. 12.0062.00
 * Fix with red Loctite 542 cod. 12.0062.00

Lubrificare con grasso al silicone cod. 12.0016.00
 ** Lubricate with silicone grease cod. 12.0016.00

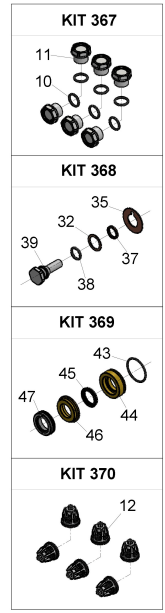
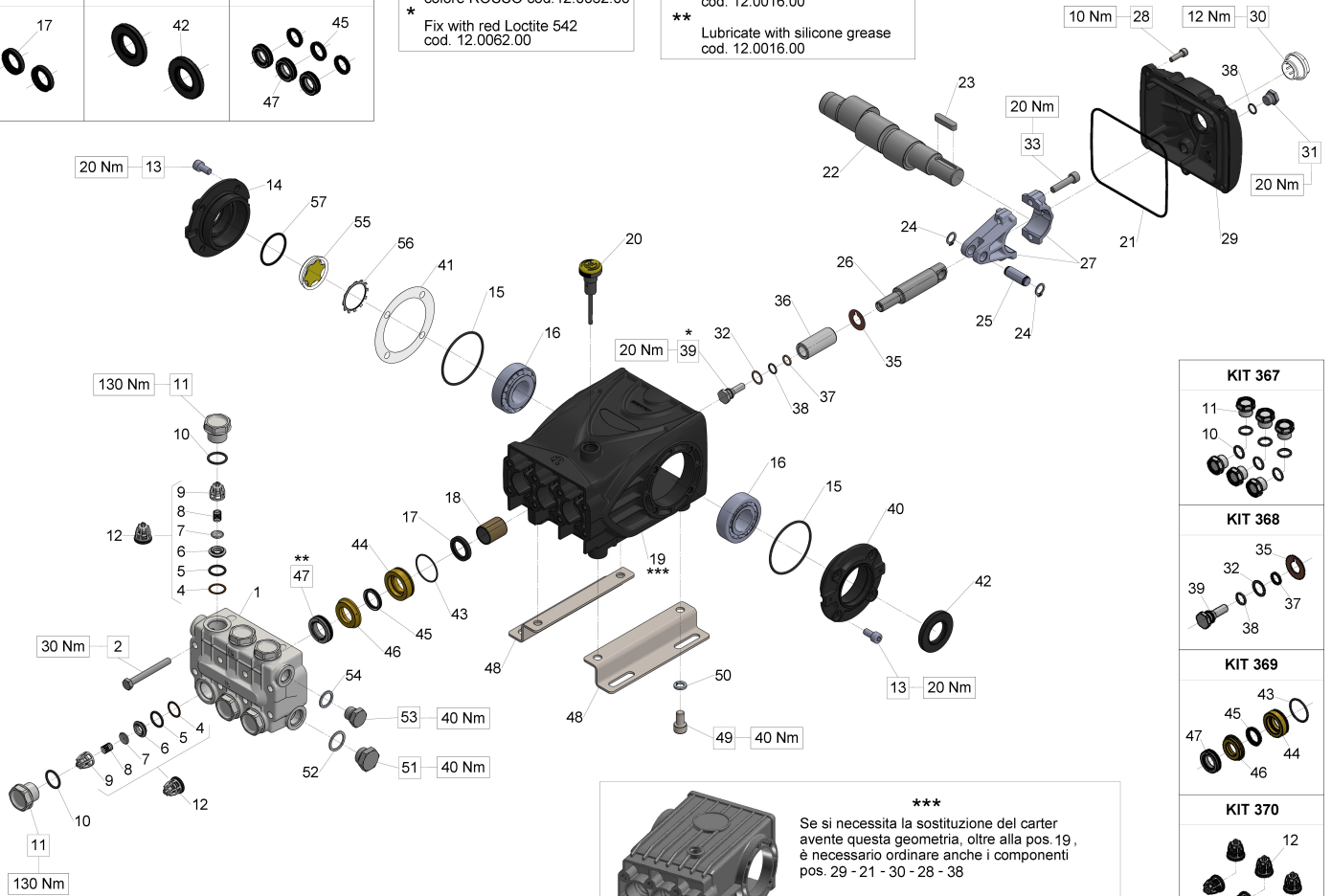

 Se si necessita la sostituzione del carter avente questa geometria, oltre alla pos. 19, è necessario ordinare anche i componenti pos. 29 - 21 - 30 - 28 - 38
 If you need to replace the crankcase that looks like this, other than pos. 19, you need to order also components pos. 29 - 21 - 30 - 28 - 38

Illustration Male shaft (key)

Pos.	Code	Description	Qty	Notes
KIT370	34037001	KIT 370 INLET/OUTLET VALVES (47 VHT)	1	
KIT369	34036901	KIT 369 CPL. SEALS D.22 (47 VHT)	1	
KIT368	34036801	KIT 368 PISTON BOLT (47 VHT)	1	
KIT367	34036701	KIT 367 VALVE PLUGS (47.VHT)	1	
KIT3	34000301	KIT 3 OIL SEAL D.30X55X7	1	
KIT202	34020201	KIT 202 SEALS D. 22 HT	1	
KIT2	34000201	KIT 2 OIL SEAL D. 22X32X5,5	1	
57	90387700	O-RING 39,34X2,62 (3156)	1	
56	90075600	CIRCLIP D.45 (ZJ45)	1	
55	70211801	OIL SIGHT GLASS	1	
54	96738000	WASHER 17,5X23X1,5	1	
53	98209900	PLUG G. 3/8X13 NICKEL	1	
52	96751400	WASHER 21,5X27X1,5	1	
51	98217900	PLUG G 1/2X10 NICKEL	1	
50	96710600	WASHER 10,2	4	
49	99364400	SCREW M 10x18-5931	4	
48	47200074	PUMP FOOT	2	
47	90231000	H.P. SEAL D. 22 (HT)	3	
46	47217570	INTERMEDIATE RING D.22 HT	3	
45	90230000	L.P. SEAL D.22 (HT)	3	
44	47081470	BACK UP RING D. 22 HT	3	
43	90361650	O-RING D. 34.65x1.78 HNBR 70SH 2137	3	
42	90164800	OIL SEAL 30x55x7	1	
41	97567800	SHIM D.74,5X104X0,1	1	
40	47151022	OPEN SIDE COVER (47-66)	1	
39	47219566	PISTON SCREW	3	
38	90358550	O-RING D.10.82x1.78 HNBR 70SH 2043	4	
37	90506700	ANTI-EXTRUSION RING	3	
36	47040509	PISTON D. 22x50	3	
35	96728600	WASHER 14X28X0,5	3	
33	99309900	SCREW M 8x35 UNI 5931	6	
32	96728000	WASHER 14X18,5X0,5	3	
31	98204250	PLUG G1/4"x12	1	
30	47221301	OIL SIGHT GLASS ASSY G3/4	1	
29	47160622	CRANKCASE COVER	1	
28	99188400	SCREW M 6x20 UNI 5931	5	

Illustration Male shaft (key)

Pos.	Code	Description	Qty	Notes
27	47030001	CONNECTING ROD	3	
26	47050466	PISTON GUIDE - S.S.	3	
25	97738000	CONNECTING-ROD PIN D.13X35,5	3	
24	90055700	CIRCLIP D.12 UNI 7435	6	
23	91489200	KEY 8(h9)X7X35 UNI 6604/A	1	
22	47022135	SHAFT C.14 SEMP. PdF USA	1	
21	90392200	O-RING D.133.02X 2,62(3525)	1	
20	98210600	OIL DIP-STICK G3/8X80	1	
19	47010822	CRANKCASE	1	
18	90912600	BUSHING 22X25X30	3	
17	90162500	OIL SEAL 22x32x5	3	
16	91837800	TAPER BEARING 32206 SKF	2	
15	90391300	O-RING 67,95X2,62 (3268)	2	
14	47151222	SIDE CRANKCASE COVER FOR OIL GAUGE	1	
13	99303900	SCREW M 8x16 UNI 5931	8	
12	36726101	INLET/OUTLET VALVE (47 VHT)	6	
11	98222200	VALVE PLUG M24X2X16 NICKEL PL.	6	
10	90384750	O-RING D. 20.29x2.62 HNBR 90SH 3081	6	
9	36200251	VALVE CAGE	6	
8	94737600	SPRING D. 9,4X14,8	6	
7	36200176	VALVE PLATE	6	
6	36200366	VALVE SEAT	6	
5	90340100	PACKING D.17.1x22.3x1.8 HNBR 90SH	6	
4	90510500	BACK-UP RING D.17.4X21.9X0.8	6	
2	99320600	HEX-HEAD SCREW M08X70 UNI5737 10.9 Fe/Zn5c1A+De	8	
1	47120941	MANIFOLD "T"	1	

Illustration Male shaft (key) - vers. ATEX

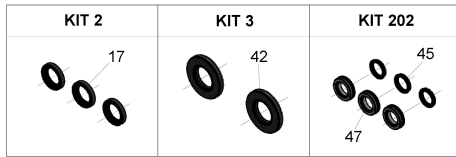

Fissare con Loctite 542
colore ROSSO cod. 12.0062.00
*
Fix with red Loctite 542
cod. 12.0062.00

Lubrificare con grasso al silicone
cod. 12.0016.00
**
Lubricate with silicone grease
cod. 12.0016.00

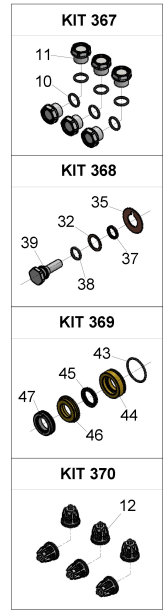
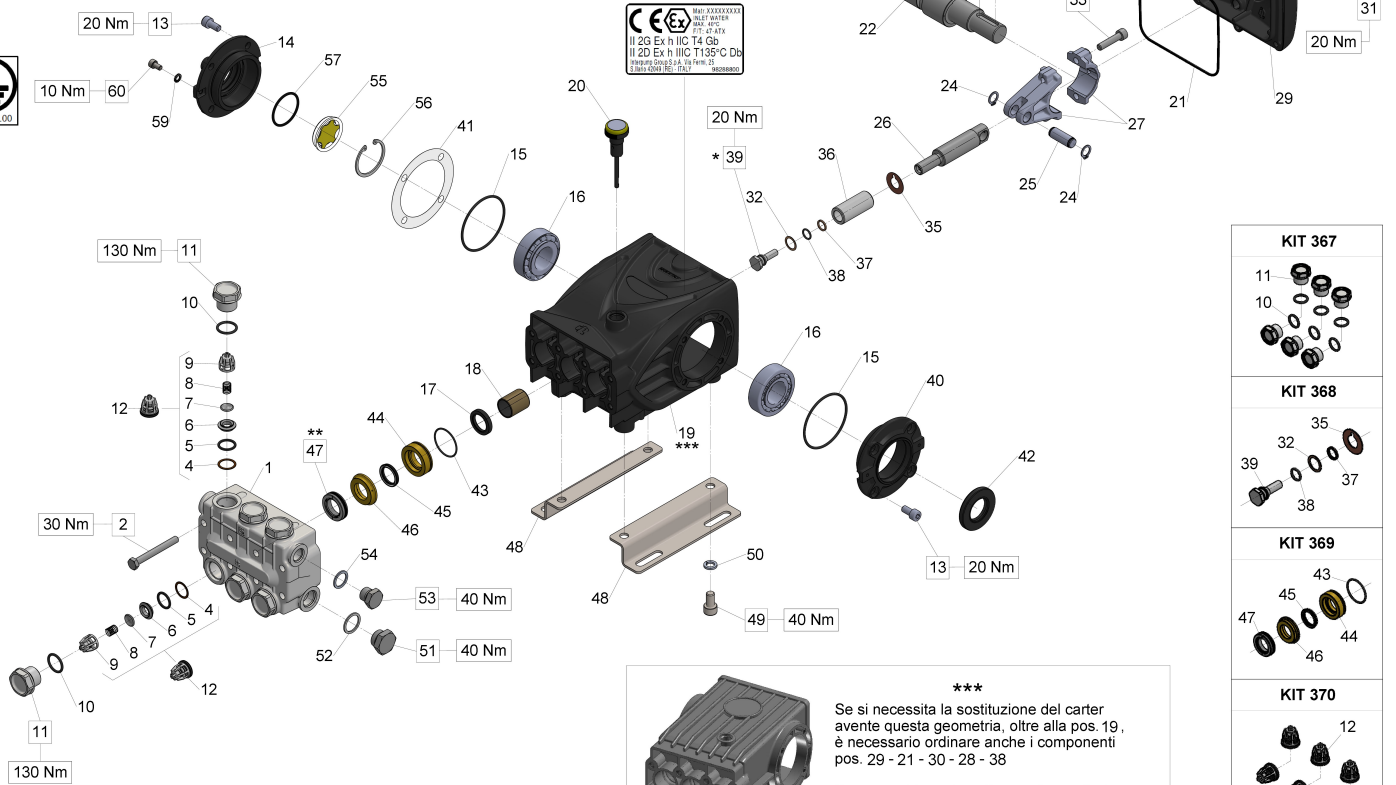

Se si necessita la sostituzione del carter
avente questa geometria, oltre alla pos. 19,
è necessario ordinare anche i componenti
pos. 29 - 21 - 30 - 28 - 38

If you need to replace the crankcase that
looks like this, other than pos. 19, you need to
order also components pos. 29 - 21 - 30 - 28 - 38

Illustration Male shaft (key) - vers. ATEX

Pos.	Code	Description	Qty	Notes
KIT370	34037001	KIT 370 INLET/OUTLET VALVES (47 VHT)	1	
KIT369	34036901	KIT 369 CPL. SEALS D.22 (47 VHT)	1	
KIT368	34036801	KIT 368 PISTON BOLT (47 VHT)	1	
KIT367	34036701	KIT 367 VALVE PLUGS (47.VHT)	1	
KIT3	34000301	KIT 3 OIL SEAL D.30X55X7	1	
KIT202	34020201	KIT 202 SEALS D. 22 HT	1	
KIT2	34000201	KIT 2 OIL SEAL D. 22X32X5,5	1	
60	99180900	SCREW M06X10 5931 A2-70	1	
59	96693950	WASHER 6.4x11.0x0.7 D6798A INOX	1	
57	90387700	O-RING 39,34X2,62 (3156)	1	
56	90075500	STOP RING J45 UNI7437	1	
55	70211801	OIL SIGHT GLASS	1	
54	96738000	WASHER 17,5X23X1,5	1	
53	98209900	PLUG G. 3/8X13 NICKEL	1	
52	96751400	WASHER 21,5X27X1,5	1	
51	98217900	PLUG G 1/2X10 NICKEL	1	
50	96710600	WASHER 10,2	4	
49	99364400	SCREW M 10x18-5931	4	
48	47200074	PUMP FOOT	2	
47	90231000	H.P. SEAL D. 22 (HT)	3	
46	47217570	INTERMEDIATE RING D.22 HT	3	
45	90230000	L.P. SEAL D.22 (HT)	3	
44	47081470	BACK UP RING D. 22 HT	3	
43	90361650	O-RING D. 34.65x1.78 HNBR 70SH 2137	3	
42	90164800	OIL SEAL 30x55x7	1	
41	97567800	SHIM D.74,5X104X0,1	1	
40	47151022	OPEN SIDE COVER (47-66)	1	
39	47219566	PISTON SCREW	3	
38	90358550	O-RING D.10.82x1.78 HNBR 70SH 2043	4	
37	90506700	ANTI-EXTRUSION RING	3	
36	47040509	PISTON D. 22x50	3	
35	96728600	WASHER 14X28X0,5	3	
33	99309900	SCREW M 8x35 UNI 5931	6	
32	96728000	WASHER 14X18,5X0,5	3	
31	98203600	PLUG G1/4x8 FOR PROBE D.6 S.S.	1	

Illustration Male shaft (key) - vers. ATEX

Pos.	Code	Description	Qty	Notes
30	98226600	PLUG G3/4X16 S.S.	1	
29	47160622	CRANKCASE COVER	1	
28	99188400	SCREW M 6x20 UNI 5931	5	
27	47030001	CONNECTING ROD	3	
26	47050466	PISTON GUIDE - S.S.	3	
25	97738000	CONNECTING-ROD PIN D.13X35,5	3	
24	90055700	CIRCLIP D.12 UNI 7435	6	
23	91489200	KEY 8(h9)X7X35 UNI 6604/A	1	
22	47022135	SHAFT C.14 SEMP. PdF USA	1	
21	90392200	O-RING D.133.02X 2,62(3525)	1	
20	98210700	OIL DIPSTICK G3/8X64 D4+FILTER ATEX	1	
19	47010822	CRANKCASE	1	
18	90912600	BUSHING 22X25X30	3	
17	90162500	OIL SEAL 22x32x5	3	
16	91837800	TAPER BEARING 32206 SKF	2	
15	90391300	O-RING 67,95X2,62 (3268)	2	
14	47151322	SIDE CRANKCASE COVER (ATEX)	1	
13	99303900	SCREW M 8x16 UNI 5931	8	
12	36726101	INLET/OUTLET VALVE (47 VHT)	6	
11	98222200	VALVE PLUG M24X2X16 NICKEL PL.	6	
10	90384750	O-RING D. 20.29x2.62 HNBR 90SH 3081	6	
9	36200251	VALVE CAGE	6	
8	94737600	SPRING D. 9,4X14,8	6	
7	36200176	VALVE PLATE	6	
6	36200366	VALVE SEAT	6	
5	90340100	PACKING D.17.1x22.3x1.8 HNBR 90SH	6	
4	90510500	BACK-UP RING D.17.4X21.9X0.8	6	
2	99320600	HEX-HEAD SCREW M08X70 UNI5737 10.9 Fe/Zn5c1A+De	8	
1	47120941	MANIFOLD "T"	1	