

## KX6/M EVO - KX7/M

Dual fuel burners gas/light oil two stages progressive (hi-low flame) or modulating (PID fully modulating) if equipped with addition of optional modulation kit and probe.

Composed by die-cast aluminum body, air blower at high pressurisation and combustion head with adjustment at high efficiency and high flame stability.

Compact overall dimensions and disposition rationalized of the components with accessibility facilitated for the easy setting and maintenance.

GAS fuel available in the versions METHANE (natural gas) or L.P.G. (to specify at the order) on demand specific versions for town gas or biogas.

Gas train composed by: working valve with regulation class A, safety valve class A, valve proving system, minimum gas pressure switch and filter stabilizer.

Burners are supplied with nozzle, fuel selection switch, flange, gasket for installation on boiler, flexible hoses, line filter.

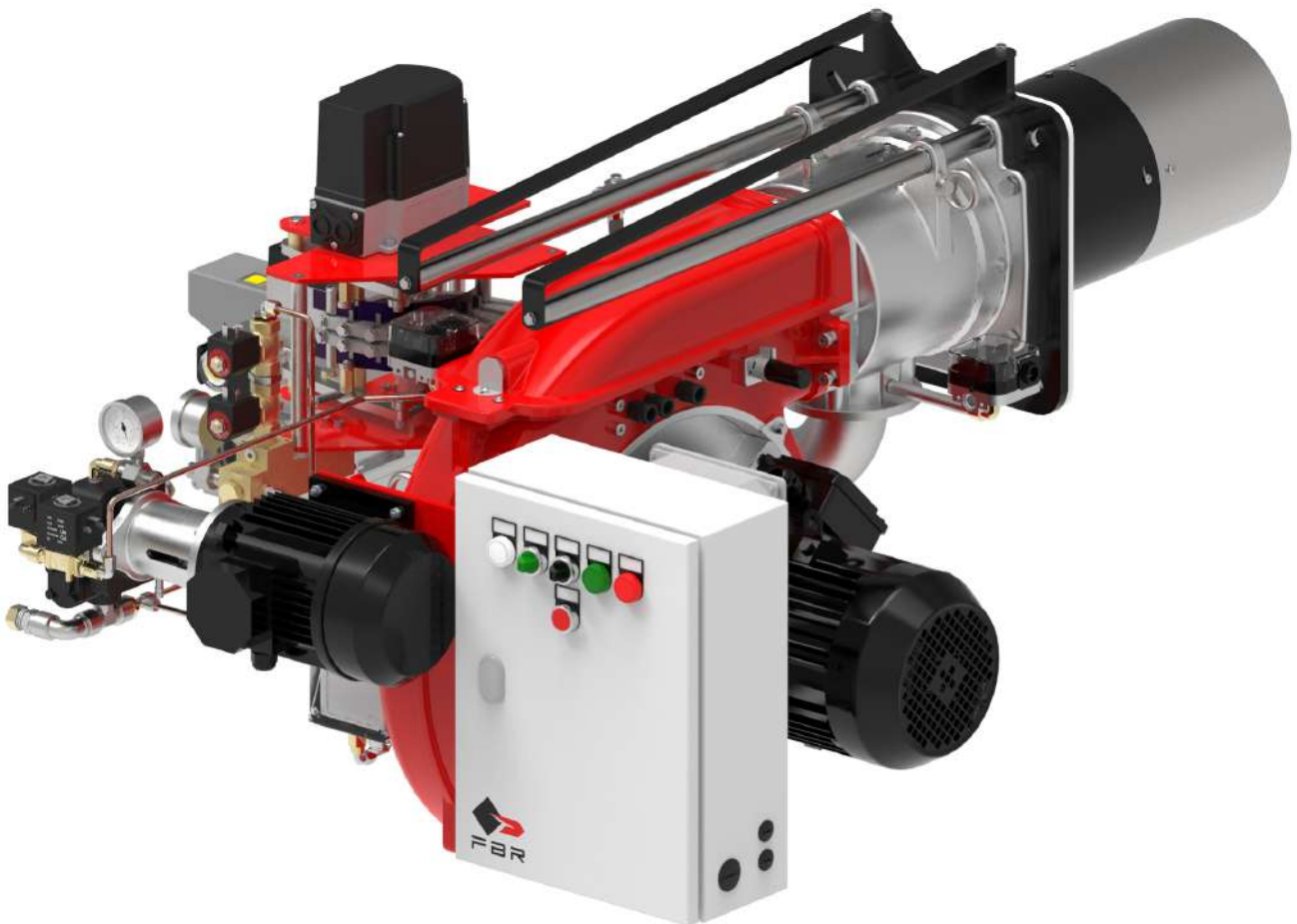

Fig. K X6/M EVO - K X7/M

## TECHNICAL DATA K X6/M EVO - K X7/M

MODEL		K X6/M EVO	K X7/M
Thermal power min. 1°st. / min. 2°st. - max. 2°st. *	[Mcal/h]	306/561-1118	367/765-1548
Thermal power min. 1°st. / min. 2°st. - max. 2°st. *	[kW]	355/652-1300	427/890-1800
Gas flow G20 (NATURAL GAS) min. 1°st. / min. 2°st. - max. 2°st. *	[Nm³/h]	35.8/65.6-130.8	43/89.5-181
Gas flow G31 (L.P.G.) min. 1°st. / min. 2°st. - max. 2°st. *	[Nm³/h]	13.8/25.2-50.3	16.5/34.5-69.7
Fuel: NATURAL GAS (second family) - L.P.G. (third family)			
Fuel category:		I2R,I2H,I2L,I2E,I2E+,I2Er,I2ELL,I2E(R),I3B/P,I3+,I3P,I3B,I3R	
Intermittent working operation (min. 1 stop every 24 hours) two stage progressive or modulating			
Environmental conditions operation / storage:		-15...+40°C / -20...+70°C, rel. humidity max. 80%	
Max. temperature combustion air	[°C]	60	60
Minimum pressure gas train D1"1/2 NATURAL GAS/L.P.G. **	[mbar]	46.2/21.5	81.8/38.4
Minimum pressure gas train D2" FS50 NATURAL GAS/L.P.G. **	[mbar]	39.8/19	69.6/33.6
Minimum pressure gas train DN65 FS65 NATURAL GAS/L.P.G. **	[mbar]	26.6/14	44.2/23.8
Minimum pressure gas train DN80 FS80 NATURAL GAS/L.P.G. **	[mbar]	21.9/12.1	35.4/20.3
Maximum pressure at the entry of valves (Pe. max) (D1"1/2-D2")	[mbar]	360	360
Maximum pressure at the entry of valves (Pe. max) (DN65-DN80)	[mbar]	500	500
LIGHT-OIL flow min. 1°st. / min. 2°st. - max. 2°st. *	[kg/h]	30/55-110	36/75-152
Fuel: light-oil 1.5°E at 20°C = 6.2 cSt = 35sec Redwood N°1			
Nominal electric power	[kW]	3.5	5.25
Fan motor	[kW]	2.2	4
Pump motor	[W]	750	750
Nominal absorption powers	[A]	6.8	9.5
Nominal absorption auxiliary	[A]	0.55	0.55
Power supply:		3~400V, 1N~230V - 50Hz	
Electric protection degree:		IP40	IP40
Noisiness *** min. - max.	[dB(A)]	82-83	84.3-86.6

\* Reference conditions: Environment temperature 20°C - Barometric pressure 1013 mbars - Altitude 0 metre (sea level).

\*\* Minimal feeding-gas pressure to the gas train to get the maximum power of the burner, considering counter-pressure in combustion chamber of value 0 (zero).

\*\*\* Measured sonorous pressure in the laboratory combustion, with functional burner on beta boiler to 1 metre of distance (UNI EN ISO 3746 law - method of control Class 3 - The tolerance of the measured pressure can be taken equal to ± 1 [dB(A)]).

OPERATING RANGE DIAGRAM

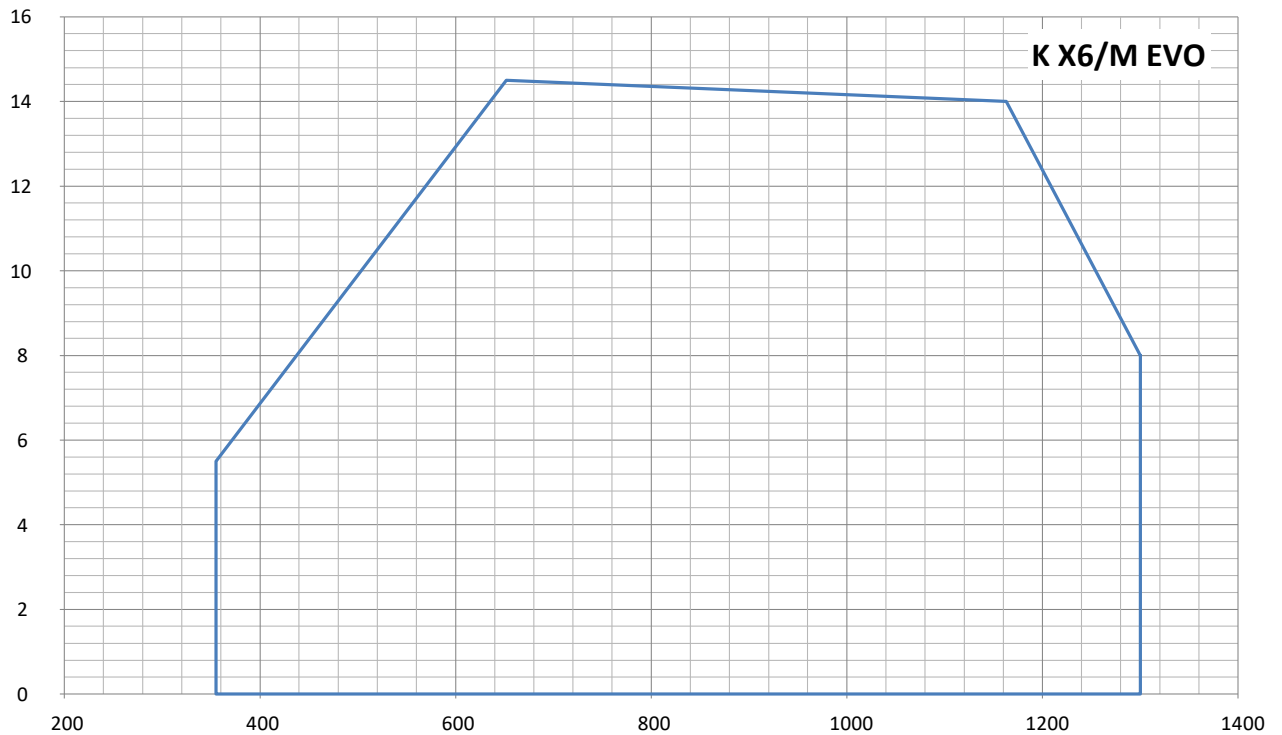

Fig. X = Thermal power [kW] Y = Pressure in combustion chamber [mbar]

The firing rates has been obtained based on test boilers in accordance with EN676 standards and are indicative of matching the burner to the boiler. For the correct operation of the burner, combustion chamber dimensions must be in accordance with current regulation. In case of non-compliance, contact the manufacturer.

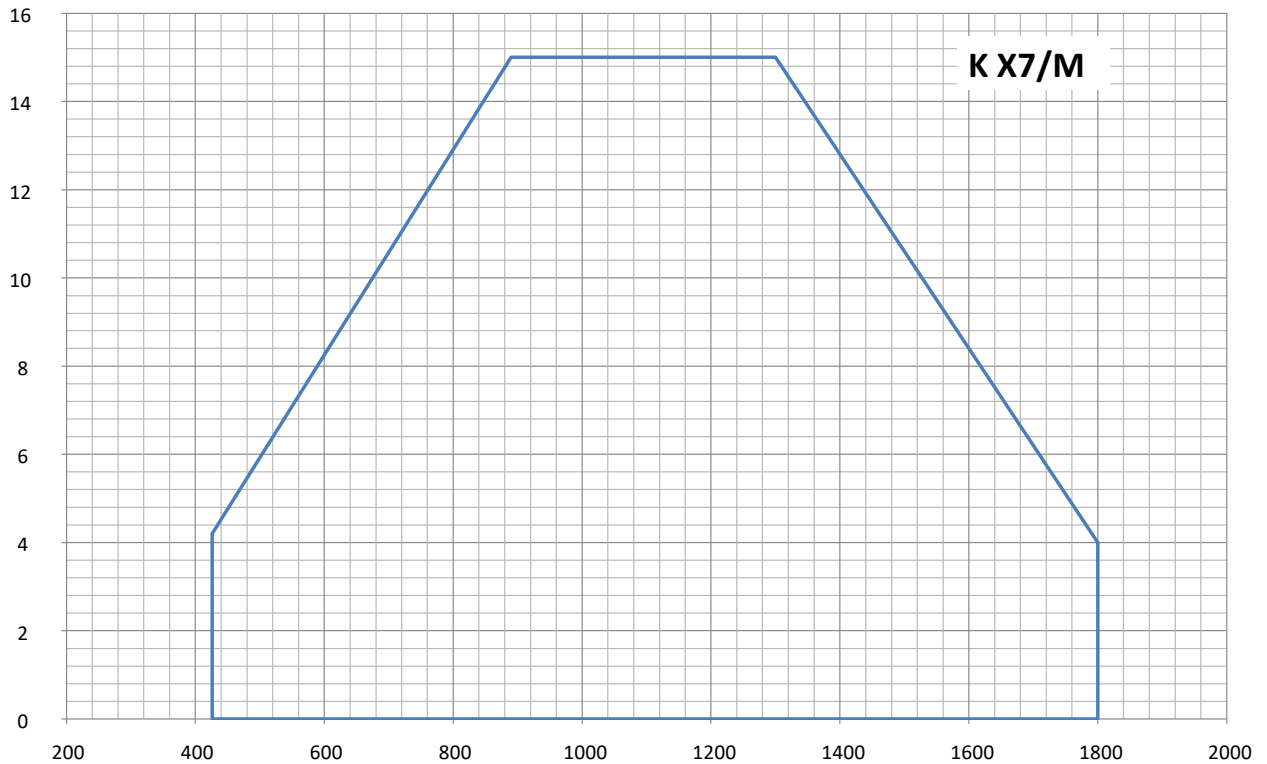

Fig. X = Thermal power [kW] Y = Pressure in combustion chamber [mbar]

The firing rates has been obtained based on test boilers in accordance with EN676 standards and are indicative of matching the burner to the boiler. For the correct operation of the burner, combustion chamber dimensions must be in accordance with current regulation. In case of non-compliance, contact the manufacturer.

**DIMENSIONS [MM]**

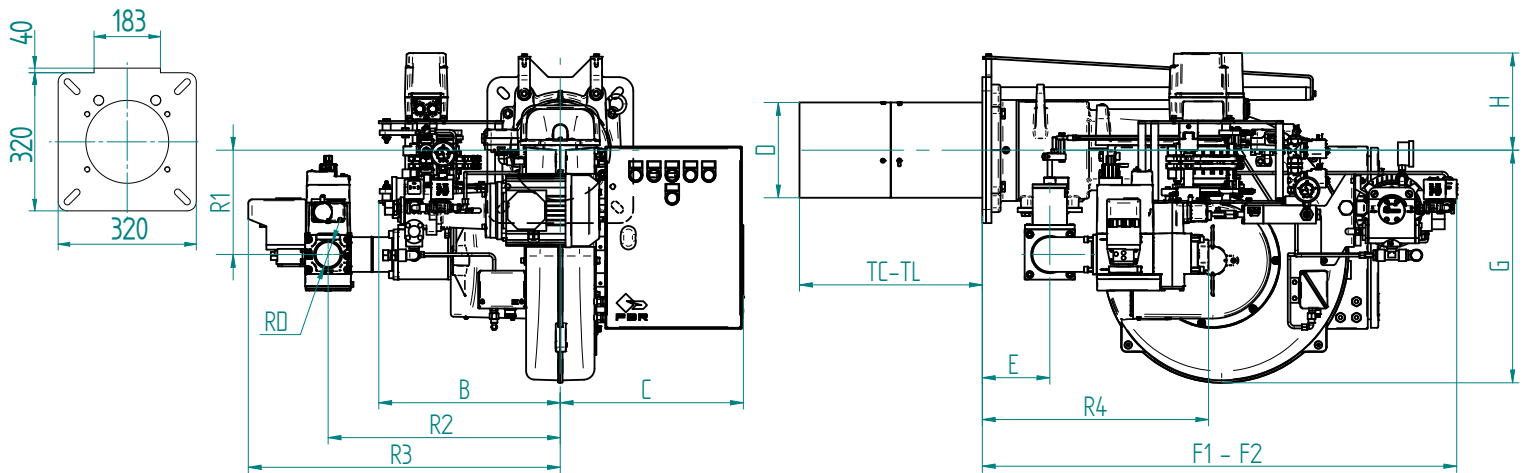

Fig. Dimensions

MODEL	B	C	D	E	F1	F2	G	H	TC*	TL**	R1	R2	R3	R4	RD	Gas train weight
K X6/M EVO - D1"1/2	398	402	209	148	1040	1624	510	213	280	400	228	510	684	496	Rp 1"1/2	22 kg
K X6/M EVO - D2"	398	402	209	148	1040	1624	510	213	280	400	228	510	684	496	Rp 2"	22 kg
K X6/M EVO - DN65	398	402	209	148	1040	1624	510	213	280	400	228	510	686	541	DN65	27 kg
K X6/M EVO - DN80	398	402	209	148	1040	1624	510	213	280	400	228	550	740	578	DN80	37 kg
K X7/M - D1"1/2	398	402	209	148	1040	1624	510	213	280	400	228	510	684	496	Rp 1"1/2	22 kg
K X7/M - D2"	398	402	209	148	1040	1624	510	213	280	400	228	510	684	496	Rp 2"	22 kg
K X7/M - DN65	398	402	209	148	1040	1624	510	213	280	400	228	510	686	541	DN65	27 kg
K X7/M - DN80	398	402	209	148	1040	1624	510	213	280	400	228	550	740	578	DN80	37 kg

\* With spacer.

\*\* For different flame tube lengths, please contact our Technical-Sales Department.

**BOILER PLATE**

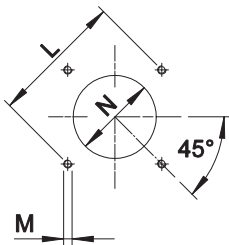

\* Suggested dimension of connection between burner and generator.

Fig. Boiler plate

MODEL		L min	L max	M	N min	N *	N max
K X6/M EVO	mm	340	368	M14	220	220	250
K X7/M	mm	340	368	M14	220	220	250

**PRODUCT SPECIFICATION****SHORT DESCRIPTION**

Dual fuel burners for gas and light-oil two stages progressive (hi-low flame) or modulating (PID fully modulating) if equipped with addition of optional modulation kit and probe.

**DETAILED SPECIFICATION**

Dual fuel burners for gas and light-oil two stages progressive (hi-low flame) or modulating (PID fully modulating) if equipped with addition of optional modulation kit and probe; composed by:

- Die-cast aluminum body;
- Fan at high pressurisation, with reverse blades for model K X6/M EVO;
- Combustion head with adjustment at high performance and elevated flame stability equipped with steel blast tube and steel flame disc;
- Flange and insulating gasket for fixing at boiler;
- Three-phase power supply;
- Safety air pressure switch to stop the burner in lock-out in case of failed or anomalous fan operation;
- Gas train with safety valve class A, adjustment valve class A and valve proving system;
- UV probe for the flame detection;
- IP 40 electric protection level;
- Spherical gas valve servo-controlled; progressive start and free way passage with total opening;
- Light-oil pressure regulator servo-controlled;
- Servomotor for air shutter, for the spherical gas valve and for the light-oil pressure regulator;
- Moving shutter with total closure when idle in order to reduce at the least energy losses related to boiler cooling down;
- Easy extraction of combustion head without get off the burners by boiler;
- Maximum gas pressure switch to stop the burner in lock-out in case of the gas pressure is higher then the set point value;
- Maximum light-oil pressure switch to stop the burner in case of the light-oil pressure on the return is higher then the set point value;
- Dedicated motor for the activation of the light-oil pump. It turns on simultaneously to the ignition transformer activation;
- Manual switch for the fuel selection "OIL - GAS";
- Supports and tierods for burner extraction;
- Set up for the additional specific kit that transforms burner operation as modulating i.e. the modulating kit allows to supply any power between the minimum and the maximum value based on instantaneous loading request.

**CONFORMING TO:**

- CE rules;
- 2014/30/UE Directive EMC;
- 2014/35/UE Directive LVD;
- 2006/42/CE - 2006/42/EG - 2006/42/EC Directive MD;
- Directive PED (art.4, par.3) 2014/68/EU;
- Reference rules: EN676 (gas) - EN267 (liquid fuel) - EN746-2 (industrial thermoprocessing equipment).

**STANDARD EQUIPMENT**

- Flexible hoses for connection;
- Line filter;
- Isomart gasket;
- Nozzle;
- Flange with insulating gasket;
- Burner nameplate;
- Warranty;
- Instruction handbook for installation, use and maintenance.

**OPTIONAL**

- Power modulating kits for temperatures;
- Power modulating kits for pressures;
- Temperature probe 0°C-400°C (PT 100 a 0° C);
- Temperature probe 0°C-1200°C (K probe);
- Pressure probe 0-3 bar, 0-6 bar, 0-16 bar, 0-20 bar, 0-30 bar;
- Noise protection;
- Antivibration couplings;
- Handle gas taps.