

K X6/2 EVO-K X7/2

Dual fuel gas/light-oil burners at two stages.

Composed by die-cast aluminum body, fan at high pressurisation and combustion head with adjustment at high efficiency and high flame stability.

Compact overall dimensions and disposition rationalized of the components with accessibility facilitated for the operations of setting and maintenance.

Available in the versions METHANE (natural gas) or L.P.G. (to specify at the order) on demand specific versions for town gas, coal gas or biogas.

Gas train with multiblock valve class A (1st stage + 2nd stage slow opening + safety), valve proving system, gas pressure switch and filter-stabilizer.

Complete of: flange and gasket for installation on generator, nozzles, flexible pipes and line filter.



Fig. K X6/2 EVO - K X7/2

TECHNICAL DATA AND OPERATING RANGE DIAGRAM K X6/2 EVO - K X7/2

MODEL		K X6/2 EVO	K X7/2
Thermal power 1 ^{st.} / min. 2 ^{st.} - max. 2 ^{st.} *	[Mcal/h]	187/561-1118	254/765-1548
Thermal power 1 ^{st.} / min. 2 ^{st.} - max. 2 ^{st.} *	[kW]	217/652-1300	295/890-1800
Gas flow G20 (NATURAL GAS) 1 ^{st.} / min. 2 ^{st.} - max. 2 ^{st.} *	[Nm ³ /h]	21.9/65.6-130.8	29.7/89.5-181
Gas flow G31 (L.P.G.) 1 ^{st.} / min. 2 ^{st.} - max. 2 ^{st.} *	[Nm ³ /h]	8.4/25.2-50.3	11.5/34.5-69.7
Fuel: NATURAL GAS (second family) - L.P.G. (third family)			
Fuel category:	I2R,I2H,I2L,I2E,I2E+,I2Er,I2ELL, I2E(R)/I3B/P,I3+,I3P,I3B,I3R		
Minimum pressure gas train D2" - S NATURAL GAS/LPG **	[mbar]	39.8/19	39.8/19
Maximum pressure at the entry of valves (Pe. max)	[mbar]	360	360
LIGHT-OIL flow 1 ^{st.} / min. 2 ^{st.} - max. 2 ^{st.} *	[kg/h]	18.5/55-110	25/75-152
Fuel: LIGHT-OIL 1,5^oE at 20°C= 6,2 cSt = 35 sec Redwood N°1			
Intermittent working operation (min. 1 stop every 24 hours) two stages			
Environmental conditions operation / storage:	-15...+40°C / -20...+70°C, rel. humidity max. 80%		
Max. temperature combustion air	[°C]	60	60
Nominal electric power	[kW]	3	4.5
Fan motor	[kW]	2.2	4
Nominal absorption fan motor	[A]	4.35	7.45
Pump motor	[kW]	0.37	0.37
Nominal absorption pump motor	[A]	1.2	1.2
Power supply:	3~400V, 1/N~230V-50Hz		
Electric protection degree:		IP 40	IP 40
Noisiness *** min. - max.	[dB(A)]	82-83	84.3-86.6

* Reference conditions: Environment temperature 20°C - Barometric pressure 1013 mbars - Altitude 0 metre (sea level).

** Minimal feeding-gas pressure to the gas train to get the maximum power of the burner, considering counter-pressure in combustion chamber of value 0 (zero).

*** Measured sonorous pressure in the laboratory combustion, with functional burner on beta boiler to 1 metre of distance (UNI EN ISO 3746 law - method of control Class 3 - The tolerance of the measured pressure can be taken equal to ± 1 [dB(A)]).

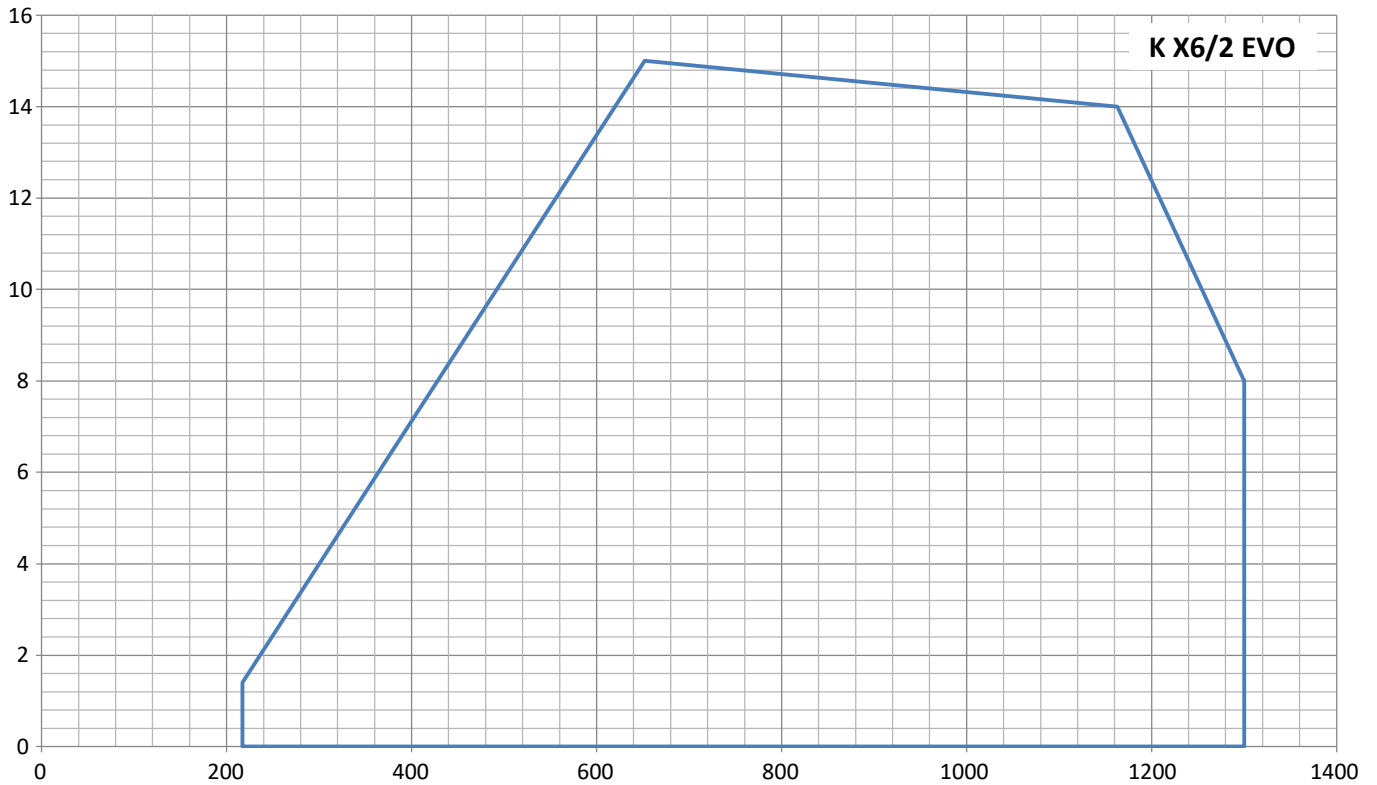

Fig. X = Thermal power [kW] Y = Pressure in combustion chamber [mbar]

The firing rates has been obtained based on test boilers in accordance with EN676 standards and are indicative of matching the burner to the boiler. For the correct operation of the burner, combustion chamber dimensions must be in accordance with current regulation. In case of non-compliance, contact the manufacturer.

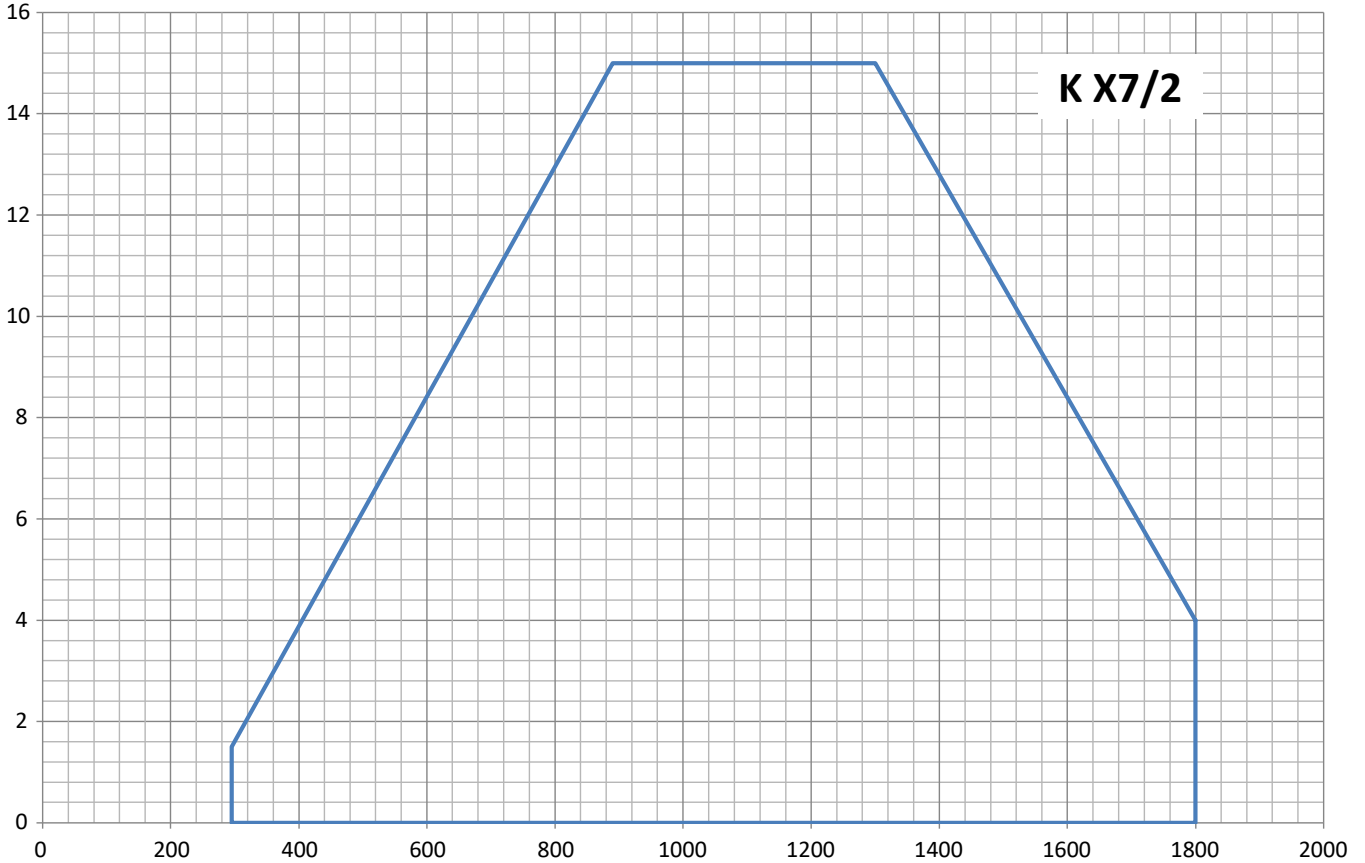

Fig. X = Thermal power [kW] Y = Pressure in combustion chamber [mbar]

The firing rates has been obtained based on test boilers in accordance with EN676 standards and are indicative of matching the burner to the boiler. For the correct operation of the burner, combustion chamber dimensions must be in accordance with current regulation. In case of non-compliance, contact the manufacturer.

DIMENSIONS [MM]

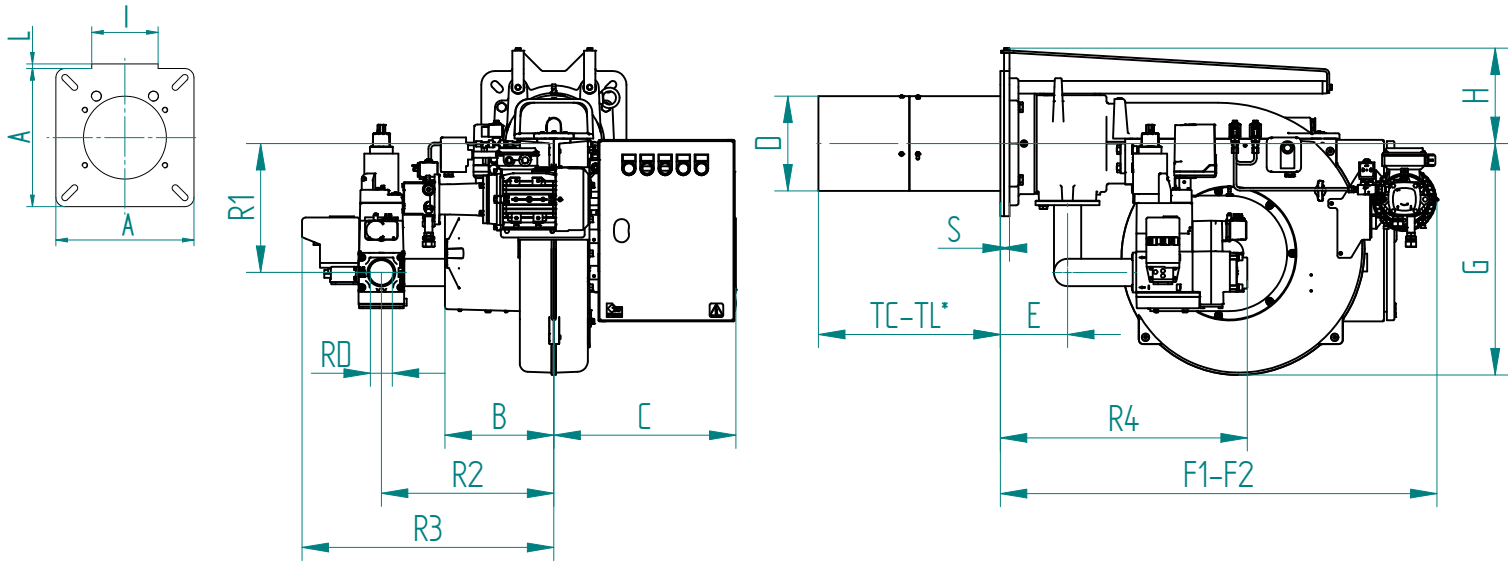

Fig. Dimensions: K X6/2 EVO - K X7/2

MODEL	A	B	C	D	E	F1	F2**	G	H	I	L	S	R1	R2	R3	R4	RD	Gas train weight
K X6/2 EVO	320	240	402	209	148	963	1548	510	210	183	40	20	284	380	555	545	Rp2	25 kg
K X7/2	320	240	398	209	148	963	1548	510	210	183	40	20	284	380	555	545	Rp2	25 kg

F2*: Encumbrance with burner move back.

TC-TL**: see chapter "FLAME TUBE LENGTH"

BOILER PLATE

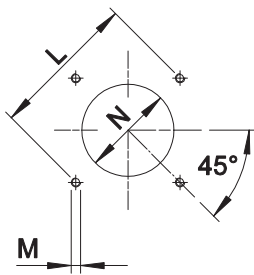

Fig. Boiler plate

* Suggested dimension of connection between burner and generator.

MODEL		L min	L max	M	N min	N *	N max
K X6/2 EVO	mm	340	368	M14	220	220	250
K X7/2	mm	340	368	M14	220	220	250

FLAME TUBE LENGTH

Flame tube length must be selected based on the specifications supplied by boiler manufacturer and, in any case, it must be greater than the thickness of the boiler door included its insulation. In case of boilers with flame inversion or front flue combustion chambers, it is necessary to insulate the area between the flame tube and front door with refractory material. This protection material must not impede flame tube extraction.

MODEL		TC	TL *
K X6/2 EVO	mm	280 **	400
K X7/2	mm	280 **	400

** With spacer.

* For different flame tube lengths, please contact our Technical-Sales Department.

PRODUCT SPECIFICATION**SHORT DESCRIPTION**

Dual fuel gas/light-oil burners at two stages.

DETAILED SPECIFICATION

Dual fuel gas/light-oil burners at two stages, composed by:

- Die-cast aluminum body;
- Fan at high pressurisation, with reverse blades for model K X6/2 EVO;
- Combustion head with adjustment at high performance and elevated flame stability equipped with inox blast tube and inox flame disc;
- Flange and insulating gasket for fixing at boiler;
- Three-phase power supply;
- Manual switch for the fuel selection gas/light-oil;
- Safety air pressure switch to stop the burner in lock-out in case of failed or anomalous fan operation;
- Complete with gas train with multiblock valve class A (1st stage + 2nd stage slow opening + safety); valve proving system, gas pressure switch and stabilizer filter;
- Motor dedicated for the light-oil pump; it turns on simultaneously to the ignition transformer activation;
- Maximum gas pressure switch;
- UV probe for flame detection;
- Supports and tierods for burner extraction;
- Easy extraction of combustion head without get off the burners by bolier;
- Servomotor for air shutter and for the consent of the 2nd stage operation;
- Moving shutter with total closure when idle in order to reduce at the least energy losses related to boiler cooling down;
- IP 40 electric protection level.

CONFORMING TO:

- CE rules;
- 2014/30/UE Directive E.M.C.;
- 2014/35/UE Directive LVD;
- 2006/42/CE - 2006/42/EG - 2006/42/EC Directive MD;
- Directive PED (art.4, par.3) 2014/68/EU;
- Reference rules: EN676 (gas) - EN267 (liquid fuel) - EN746-2 (industrial thermoprocessing equipment).

STANDARD EQUIPMENT

- Flexible pipes;
- Line filter;
- Isomart gasket;
- Nozzles;
- Flange with insulating gasket;
- Burner nameplate;
- Warranty;
- Instruction handbook for installation, use and maintenance.

OPTIONAL

- Noise protection;
- Antivibration couplings;
- Handle gas taps.