

K X6/M-EL EVO - K X7/M-EL

Dual fuel burners gas/light oil with electronic control box. Two stages progressive or modulating operation (if equipped with addition of optional modulation kit PID and probe: to guarantee an ideal proportionality of the power supplied to the thermal load).

Composed by: die-cast aluminum body, fan at high pressurisation and combustion head with adjustment at high efficiency and high flame stability.

Compact overall dimensions and disposition rationalized of the components with accessibility facilitated for the operations of setting and maintenance.

Available in the versions METHANE (natural gas) or L.P.G. (to specify at the order) on demand specific versions for town gas or biogas.

Gas train complete of: working valve class A, safety valve class A, gas valve proving pressure switch, minimum gaspressure switch, filter.

Supplied with: nozzle, flange and gasket for installation on boiler, flexible hoses, line filter.

The servomotors are independent and managed directly from the electronic control box of the burner: one servomotor for the gas modulator, one servomotor for the air shutter and one servomotor for the light-oil modulator.

The burners are equipped with a display that allows to:

- adjust the operating parameters of the burner
- visualize the flame intensity
- adjust the operating curve of the burner (air / fuel ratio)

With the addition of optional accessories (PID electronic regulator and probe) thanks to the most advanced systems for automatic modulation in mechanical or electronic version, the burner constantly ensures the proper thermal load. The maximum efficiency of the returns in each combustion point derived from the punctual adaptation of the thermal load to the heat requirements of the burner at any instant of operation.

In the version with the electronic cam the fuel / combustion air curve, more extended, is fully exploited, guaranteeing excellent performance in terms of accuracy and speed, even during the calibration phase.

A microprocessor monitors the different stages of the process and allows the correct repetition of the sequences of operation.

Optional accessories: PID power modulator kit, probe, PC interface, VSD, O2 control, O2 + CO control, field bus (profibus, modbus, profinet), Touchscreen HMI panel.

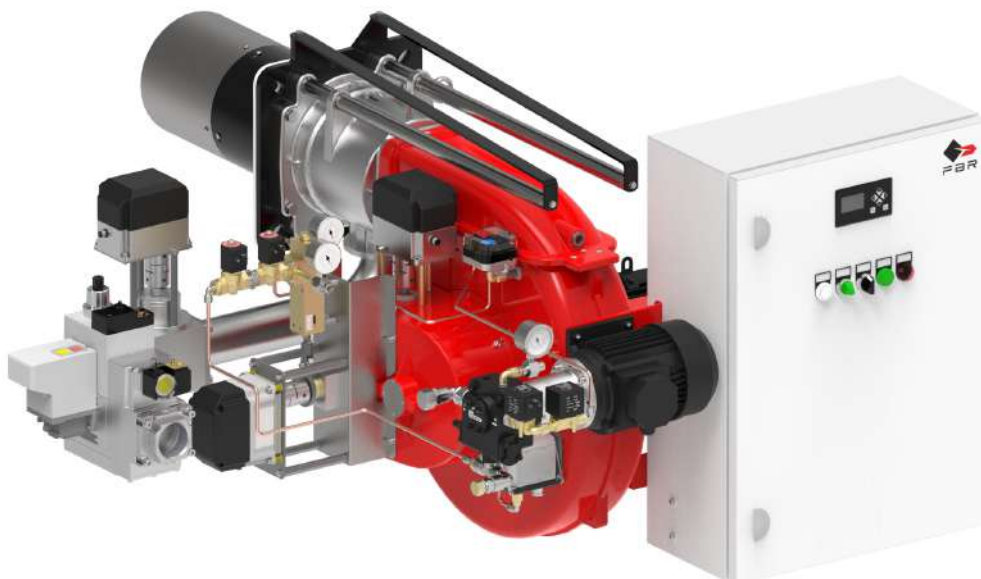

Fig. K X7/M-EL

CONTROL BOX LAMTEC BT3

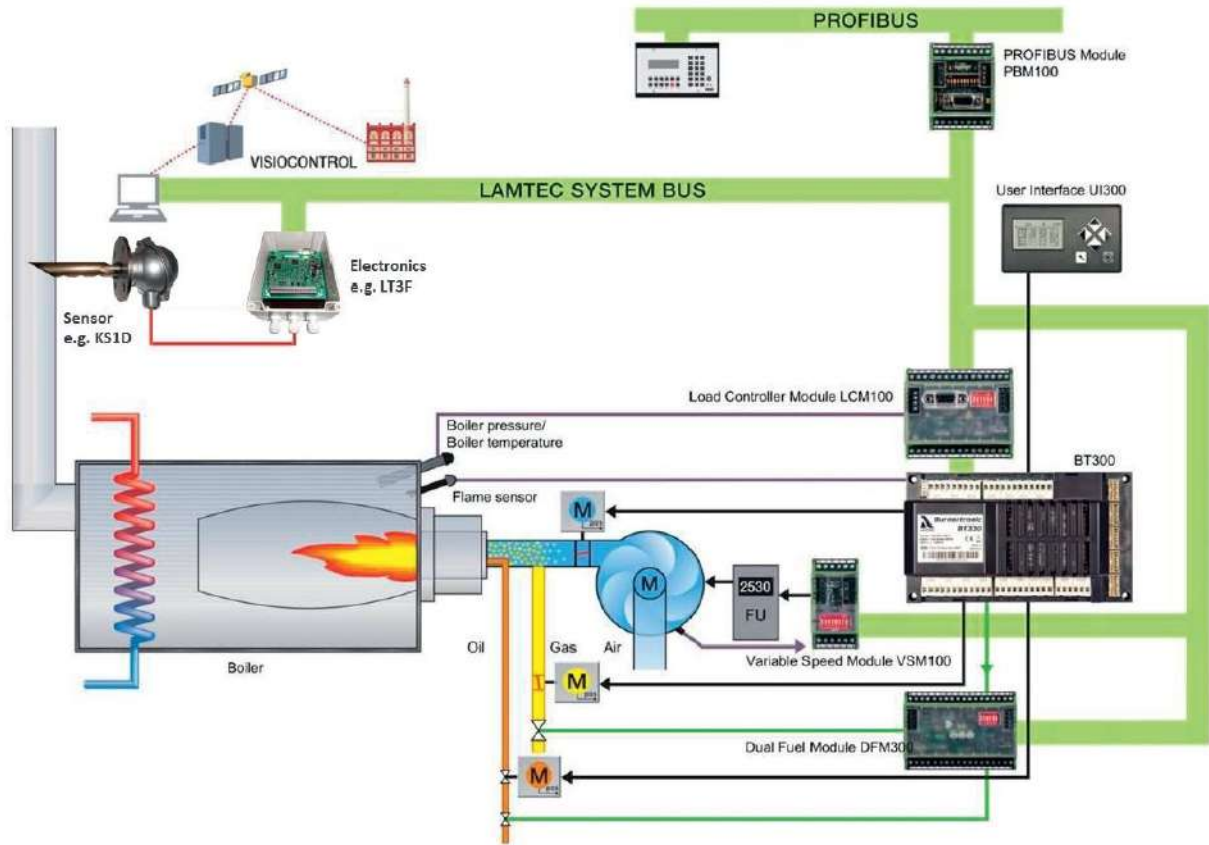

Fig. Control box Lamtec BT3

TECHNICAL DATA K X6/M-EL EVO - K X7/M-EL

MODEL		K X6/M-EL EVO	K X7/M-EL
Thermal power min. 1°st. / min. 2°st. - max. 2°st. *	[Mcal/h]	306/561-1118	367/765-1548
Thermal power min. 1°st. / min. 2°st. - max. 2°st. *	[kW]	355/652-1300	427/890-1800
Gas flow G20 (NATURAL GAS) min. 1°st. / min. 2°st. - max. 2°st. *	[Nm ³ /h]	35.8/65.6-130.8	43/89.5-181
Gas flow G31 (L.P.G.) min. 1°st. / min. 2°st. - max. 2°st. *	[Nm ³ /h]	13.8/25.2-50.3	16.5/34.5-69.7
Fuel: NATURAL GAS (second family) - L.P.G. (third family)			
Fuel category:		I2R,I2H,I2L,I2E,I2E+,I2Er,I2ELL,I2E(R),I3B/P,I3+,I3P,I3B,I3R	
Intermittent working operation (min. 1 stop every 24 hours) two stage progressive or modulating			
Environmental conditions operation / storage:		-15...+40°C / -20...+70°C, rel. humidity max. 80%	
Max. temperature combustion air	[°C]	60	60
Minimum pressure gas train D1"1/2 NATURAL GAS/L.P.G. **	[mbar]	46.2/21.5	81.8/38.4
Minimum pressure gas train D2" FS50 NATURAL GAS/L.P.G. **	[mbar]	39.8/19	69.6/33.6
Minimum pressure gas train DN65 FS65 NATURAL GAS/L.P.G. **	[mbar]	26.6/14	44.2/23.8
Minimum pressure gas train DN80 FS80 NATURAL GAS/L.P.G. **	[mbar]	21.9/12.1	35.4/20.3
Maximum pressure at the entry of valves (Pe. max) (D1"1/2 - D2")	[mbar]	360	360
Maximum pressure at the entry of valves (Pe. max) (DN65 - DN80)	[mbar]	500	500
LIGHT-OIL flow min. 1°st. / min. 2°st. - max. 2°st. *	[kg/h]	30/55-110	36/75-152
Fuel: light-oil 1.5°E at 20°C = 6.2 cSt = 35sec Redwood N°1			
Nominal electric power	[kW]	3.5	5.25
Fan motor	[kW]	2.2	4
Pump motor	[W]	750	750
Nominal absorption powers	[A]	6.8	9.5
Nominal absorption auxiliary	[A]	0.55	0.55
Power supply:		3~400V, 1N~230V - 50Hz	
Electric protection degree:		IP40	IP40
Noisiness *** min. - max.	[dB(A)]	82-83	84.3-86.6

* Reference conditions: Environment temperature 20°C - Barometric pressure 1013 mbars - Altitude 0 metre (sea level).

** Minimal feeding-gas pressure to the gas train to get the maximum power of the burner, considering counter-pressure in combustion chamber of value 0 (zero).

*** Measured sonorous pressure in the laboratory combustion, with functional burner on beta boiler to 1 metre of distance (UNI EN ISO 3746 law - method of control Class 3 - The tolerance of the measured pressure can be taken equal to ± 1 [dB(A)]).

OPERATING RANGE DIAGRAM

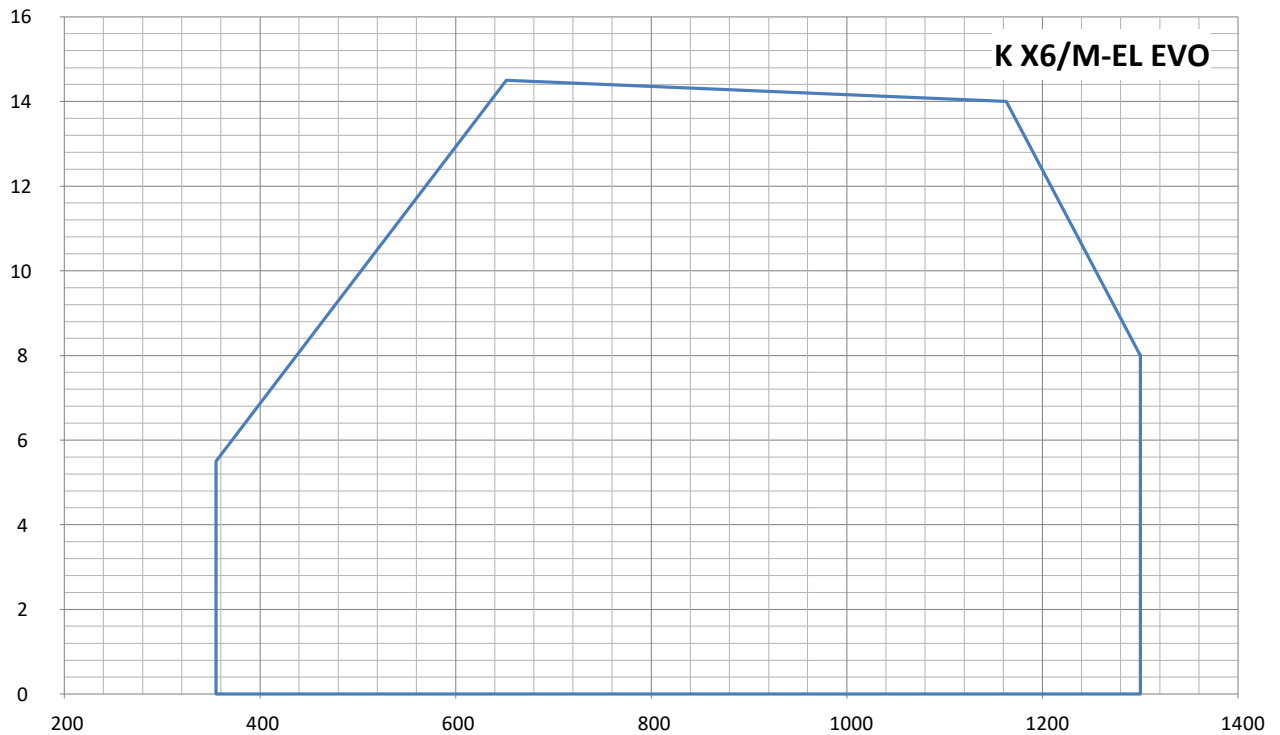

Fig. X = Thermal power [kW] Y = Pressure in combustion chamber [mbar]

The firing rates has been obtained based on test boilers in accordance with EN676 standards and are indicative of matching the burner to the boiler. For the correct operation of the burner, combustion chamber dimensions must be in accordance with current regulation. In case of non-compliance, contact the manufacturer.

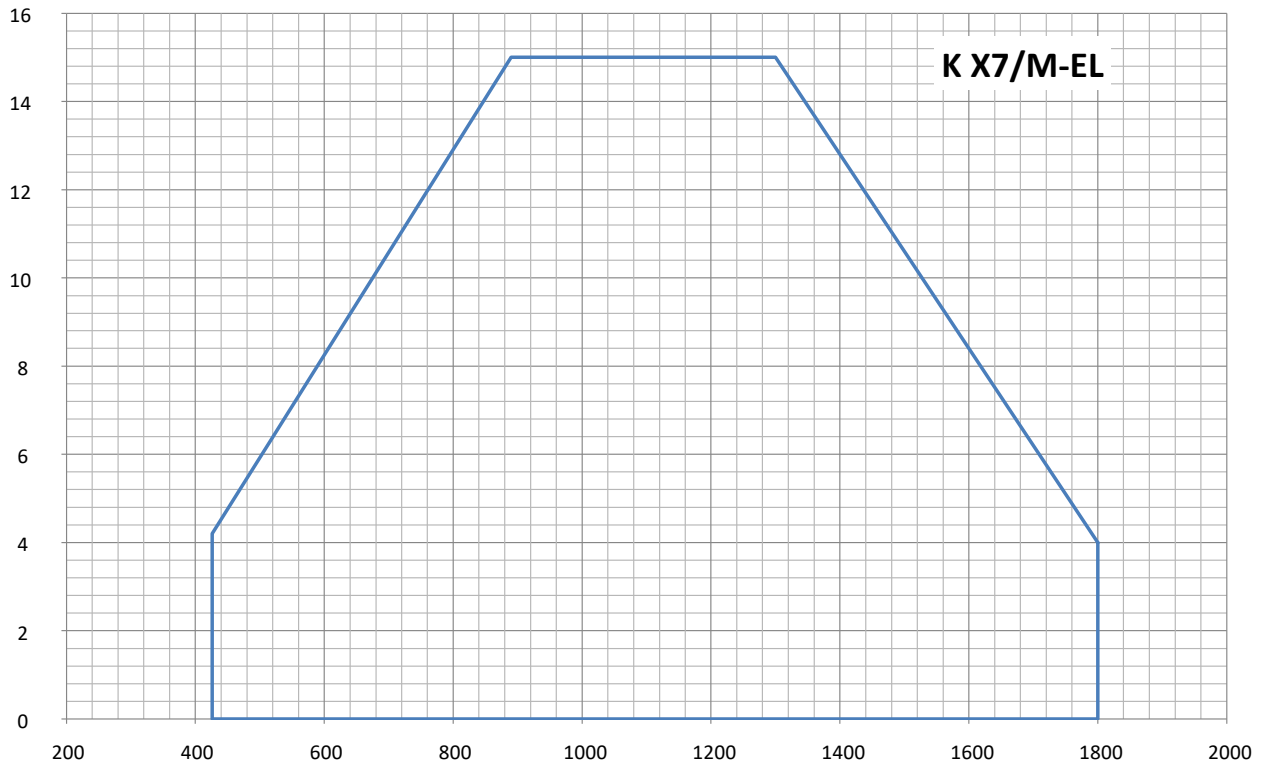

Fig. X = Thermal power [kW] Y = pressure in combustion chamber [mbar]

The firing rates has been obtained based on test boilers in accordance with EN676 standards and are indicative of matching the burner to the boiler. For the correct operation of the burner, combustion chamber dimensions must be in accordance with current regulation. In case of non-compliance, contact the manufacturer.

DIMENSIONS [MM]

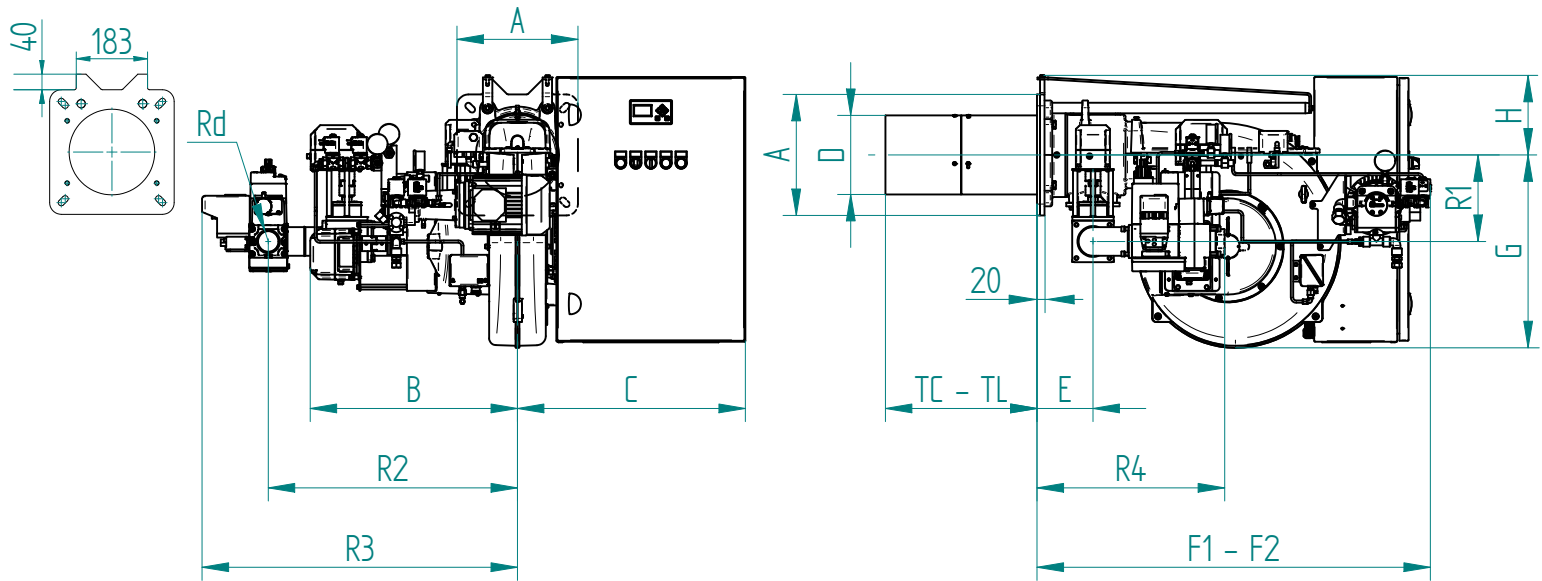

Fig. Dimensions

MODEL	A	B	C	D	E	F1	F2	G	H	TC*	TL**	R1	R2	R3	R4	RD	Gas train weight
K X6/M-EL EVO - D1"1/2	320	550	603	209	148	1040	1630	510	210	280	400	228	660	835	496	Rp 1"1/2	22 kg
K X6/M-EL EVO - D2"	320	550	603	209	148	1040	1630	510	210	280	400	228	660	835	496	Rp 2"	22 kg
K X6/M-EL EVO - DN65	320	550	603	209	148	1040	1630	510	210	280	400	228	660	835	541	DN65	27 kg
K X6/M-EL EVO - DN80	320	550	603	209	148	1040	1630	510	210	280	400	228	700	890	578	DN80	37 kg
K X7/M-EL - D1"1/2	320	550	603	209	148	1040	1630	510	210	280	400	228	660	835	496	Rp 1"1/2	22 kg
K X7/M-EL - D2"	320	550	603	209	148	1040	1630	510	210	280	400	228	660	835	496	Rp 2"	22 kg
K X7/M-EL - DN65	320	550	603	209	148	1040	1630	510	210	280	400	228	660	835	541	DN65	27 kg
K X7/M-EL - DN80	320	550	603	209	148	1040	1630	510	210	280	400	228	700	890	578	DN80	37 kg

* With spacers

** For different flame lengths, please contact our Technical-Sales Department.

BOILER PLATE

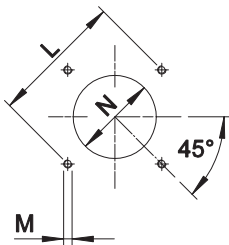

* The dimensions of the boiler plate (threaded holes or studs) must be as indicated in the drawing.

Fig. Boiler plate

MODEL		L min	L max	M	N min	N *	N max
K X6/M-EL EVO	mm	340	368	M14	220	220	250
K X7/M-EL	mm	340	368	M14	220	220	250

PRODUCT SPECIFICATION

SHORT DESCRIPTION

Dual fuel burners for gas and light-oil two stages progressive (hi-low flame) or modulating (PID fully modulating) if equipped with addition of optional modulation kit and probe.

DETAILED SPECIFICATION

Gas and Light-oil burner two stages progressive (hi-low flame) or modulating (PID fully modulating) if equipped with addition of optional modulation kit and probe; composed by:

- Die-cast aluminum body;
- Fan at high pressurisation, at reverse blades for model K X6/M-EL EVO;
- Combustion head with adjustment at high performance and elevated flame stability equipped with steel blast tube and steel flame disc;
- Flange and insulating gasket for fixing at boiler;
- Three-phase power supply;
- Safety air pressure switch to stop the burner in lock-out in case of failed or anomalous fan operation;
- Gas train complete of: working valve class A - safety valve class A - minimum gas pressure switch - gas valve proving pressure switch - filter;
- UV probe for the flame detection;
- IP 40 electric protection level;
- Spherical gas valve servo-controlled with dedicated servomotor; progressive start and free way passage with total opening;
- Light-oil pressure regulator servo-controlled with dedicated servomotor;
- Servomotor for air shutter;
- Moving shutter with total closure when idle in order to reduce at the least energy losses related to boiler cooling down;
- Easy extraction of combustion head without get off the burners by boiler;
- Maximum gas pressure switch to stop the burner in lock-out in case of the gas pressure is higher then the set point value;
- Maximum light-oil pressure switch to stop the burner in case of the light-oil pressure on the return is higher then the set point value;
- Dedicated motor for the activation of the light-oil pump. It activates simultaneously with the activation of the burner ignition transformer;
- Manual switch for the fuel selection "OIL - GAS";
- Burner extraction pins and tie rods for easy maintenance;
- Set up for the additional specific kit that transforms burner operation as modulating i.e. the modulating kit allows to supply any power between the minimum and the maximum value based on instantaneous loading request.
- Direct fan motor start;
- Burner terminal strip with terminal dedicated for 3ph/1ph power supply and for the connections to thermostats/boiler in-out signals;

CONFORMING TO:

- CE rules;
- 2014/30/UE Directive E.M.C.;
- 2014/35/UE Directive L.V.;
- 2006/42/CE - 2006/42/EG - 2006/42/EC Directive M.D.;
- 2014/68/EU Directive P.E.D. (Art. 4, par. 3);
- Reference rules: EN676 (gas) - EN267 (liquid fuel) - EN746-2 (industrial thermoprocessing equipment).

STANDARD EQUIPMENT

- Flexible hoses for connection;
- Line filter;
- Isomart gasket;
- Nozzle;
- Flange with insulating gasket;
- Burner nameplate;
- Warranty;
- Instruction handbook for installation, use and maintenance.



DUAL FUEL GAS/LIGHT-OIL BURNERS TWO STAGES PROGRESSIVE OR MODULATING WITH ELECTRONIC CONTROL BOX

SK073568_C_en

OPTIONAL

- Power modulating kits for temperatures;
- Power modulating kits for pressures;
- Kit for input 4-20mA / 0-10Vdc;
- Temperature probe 0°C-400°C (PT 100 a 0° C);
- Temperature probe 0°C-350°C (J probe);
- Temperature probe 0°C-1200°C (K probe);
- Pressure probe 0-3 bar, 0-6 bar, 0-16 bar, 0-20 bar, 0-30 bar;
- Sensors and system for O₂ control (is suggest to add the VSD);
- Sensors and system for CO control (is suggest to add the VSD);
- Sensors and system for O₂-CO control (is suggest to add the VSD);
- Modules for field BUS (modbus - profibus - profinet);
- HMI Touchscreen panel (7", 10", 15");
- Noise protection;
- Antivibration couplings;
- Handle gas taps.