

GAS P190-250-300/MCE-LX-EL

Burners for gas with electronic control box. Two stages progressive or modulating operation (if equipped with addition of optional modulation kit PID and probe; to guarantee an ideal proportionality of the power supplied to the thermal load).

Composed by: fan at high pressurisation, additional large diameter flange on the fan motor for easy extraction of the motor group + fan and combustion head with adjustment at high efficiency and high flame stability. Compact overall dimensions and disposition rationalized of the components with accessibility facilitated for operations of setting and maintenance.

Equipped as standard with UV probe and pilot flame.

Gas train completely assembled and tested; complete of: working valve class A - safety valve class A - minimum gas pressure switch - gas valve proving pressure switch - filter.

Complete of flange and gasket for installation on generator.

The servomotors are independent and managed directly from the electronic control box of the burner: one servomotor for the gas modulator and one servomotor for the air shutter.

The burners are equipped with a display that allows to:

- adjust the operating parameters of the burner
- visualize the flame intensity
- adjust the operating curve of the burner (air / gas ratio)

With the addition of optional accessories (probes) thanks to the most advanced systems for automatic modulation in mechanical or electronic version, the burner constantly ensures the proper gas / air ratio. The maximum efficiency of the returns in each combustion point derived from the punctual adaptation of the thermal load to the heat requirements of the burner at any instant of operation.

In the version with the electronic cam the fuel / combustion air curve, more extended, is fully exploited, guaranteeing excellent performance in terms of accuracy and speed, even during the calibration phase.

A microprocessor monitors the different stages of the process and allows the correct repetition of the sequences of operation.

Optional accessories: PID power modulator kit, probe, PC interface, VSD, O₂ control, O₂ + CO control, field bus (profibus, modbus, profinet).

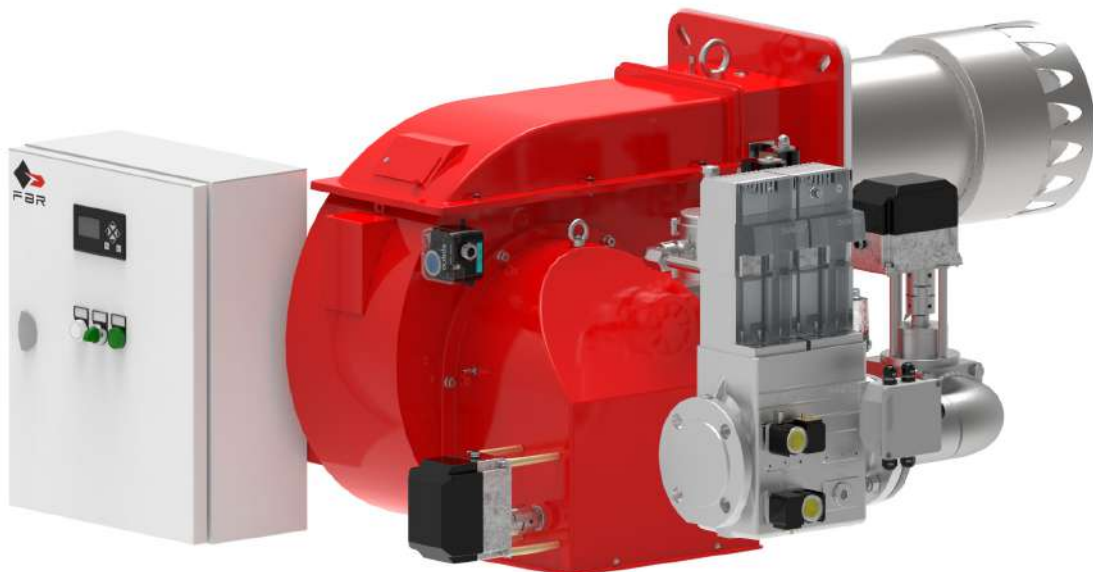

CONTROL BOX LAMTEC BT3

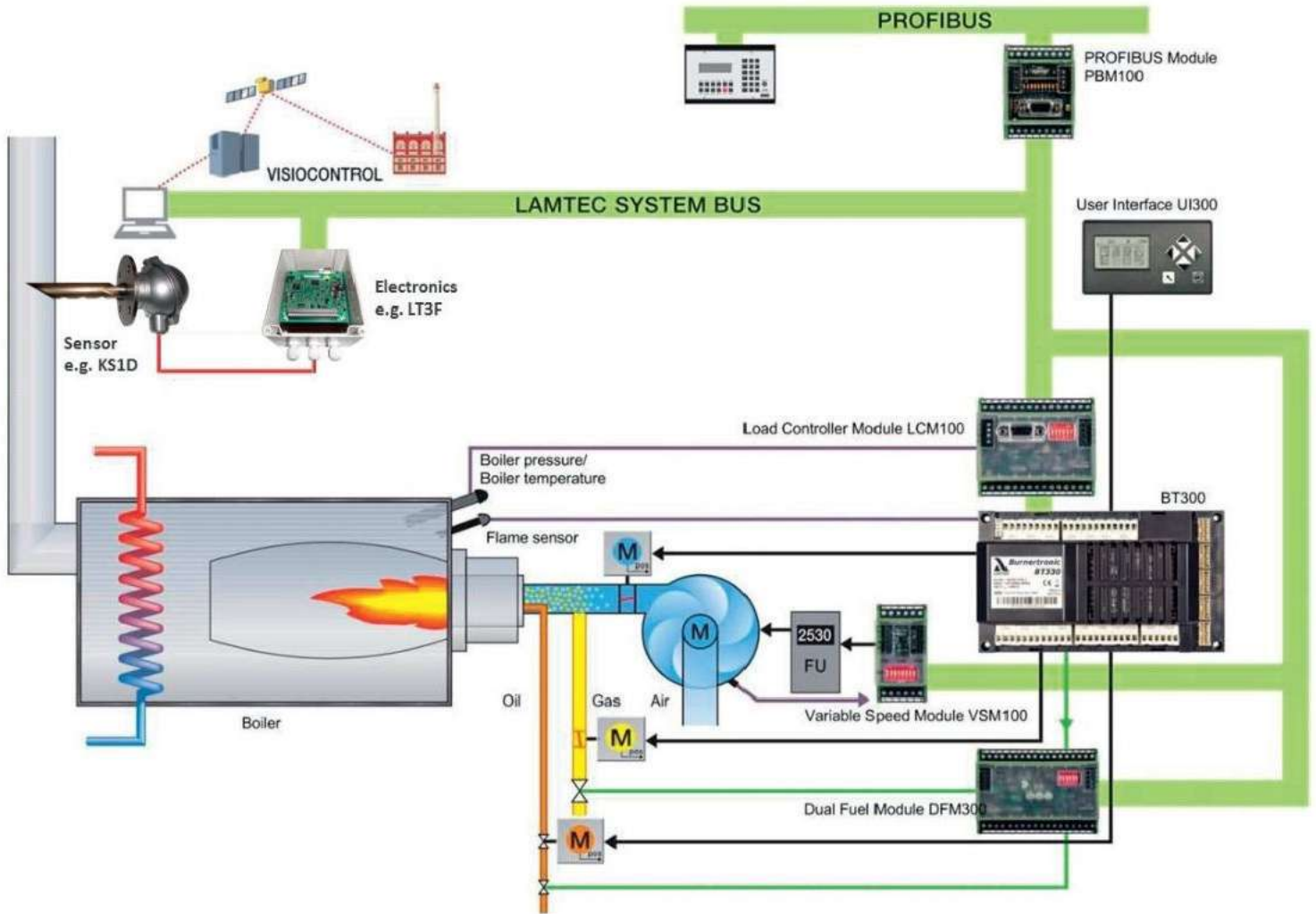

Fig. 1 Control box Lamtec BT3

TECHNICAL DATA

MODEL		GAS P190/MCE -LX-EL	GAS P250/MCE -LX-EL	GAS P300/MCE -LX-EL
Thermal power min. 1°st. / min. 2°st. - max. 2°st. *	[Mcal/h]	300/900-1900	400/1000-2500	483/1204-3000
Thermal power min. 1°st. / min. 2°st. - max. 2°st. *	[kW]	349/1046-2209	465/1163-2907	562/1400-3488
Gas flow G20 (NATURAL GAS) min. 1°st. / min. 2°st. - max. 2°st. *	[Nm³/h]	35/105-222	47/117-292	47/140-351
Fuel: NATURAL GAS (second family)				
Fuel category:		I2R,I2H,I2L,I2E,I2E+,I2Er,I2ELL,I2E(R)		
NOx **	[mg/kWh]	< 80: class 3 (EN 676)		
Intermittent working operation (min. 1 stop every 24 hours) two stages progressive or modulating				
Environmental conditions operation / storage:		-15...+40°C / -20...+70°C, rel. humidity max. 80%		
Max. temperature combustion air	[°C]	60	60	60
Minimum pressure gas train D2"-S-F50 NATURAL GAS ***	[mbar]	86.7	150	225
Minimum pressure gas train DN65-S-F65 NATURAL GAS ***	[mbar]	51	88	129
Minimum pressure gas train DN80-S-F80 NATURAL GAS ***	[mbar]	38	66	96
Minimum pressure gas train DN100-S-F100 NATURAL GAS ***	[mbar]	28	48	66
Maximum pressure at the entry of valves (Pe. max)	[mbar]	500	500	500
Nominal electric power	[kW]	4.5	6	8
Fan motor	[kW]	4	5.5	7.5
Nominal motor current absorption	[A]	8.6	12.3	15.8
Nominal auxiliary absorption	[A]	0.5	0.5	0.6
Power supply:		3~400V, 1N~230V - 50Hz		
Electric protection degree		IP40	IP40	IP40
Noisiness **** min. - max.	[dB(A)]	79-82	79-82	81-85
Burner weight	[kg]	128	120	122

* Reference conditions: Environment temperature 20°C - Barometric pressure 1013 mbars - Altitude 0 metre (sea level).

** To obtain this low Nox emission like in the declaration, it's necessary to couple the burner to the proper boiler for this application: boilers with 3 turns for the exhaust gas, condensing boilers and any generator with direct exhaust outlet and the thermal load isn't higher than 1,1 MW/m³.

*** Minimal feeding-gas pressure to the gas train to get the maximum power of the burner, considering counter-pressure in combustion chamber of value 0 (zero).

**** Measured sonorous pressure in the laboratory combustion, with functional burner on beta boiler to 1 metre of distance (UNI EN ISO 3746 - Control method Class 3 - The tolerance on the measured sound pressure can be assumed equal to ± 1 [dB (A)]).

OPERATING RANGE DIAGRAM

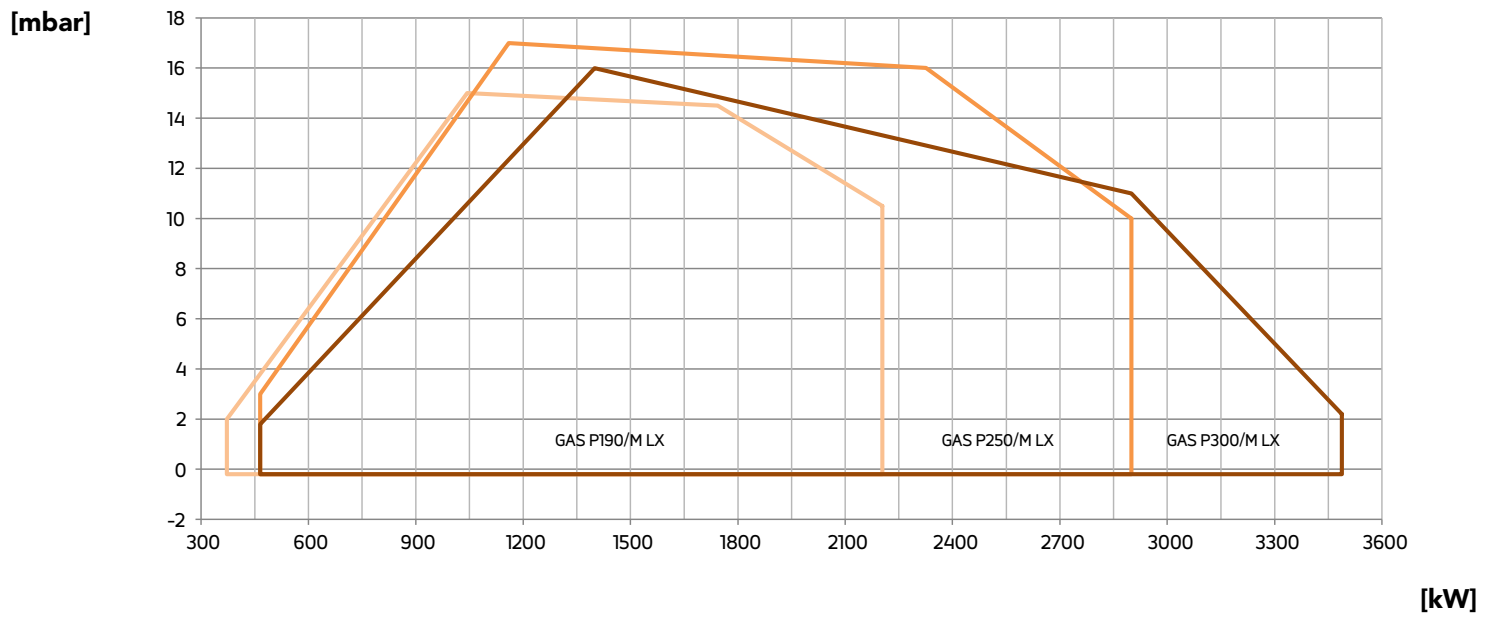

Fig. 2 X = Thermal power [kW] Y = Pression in the combustion chamber [mbar]

The firing rates has been obtained based on test boilers in accordance with EN676 standards and are indicative of matching the burner to the boiler. For the correct operation of the burner bruciatore, combustion chamber dimensions must be in accordance with current regulation. In case of non-compliance, contact the manufacturer.

DIMENSIONS [MM]

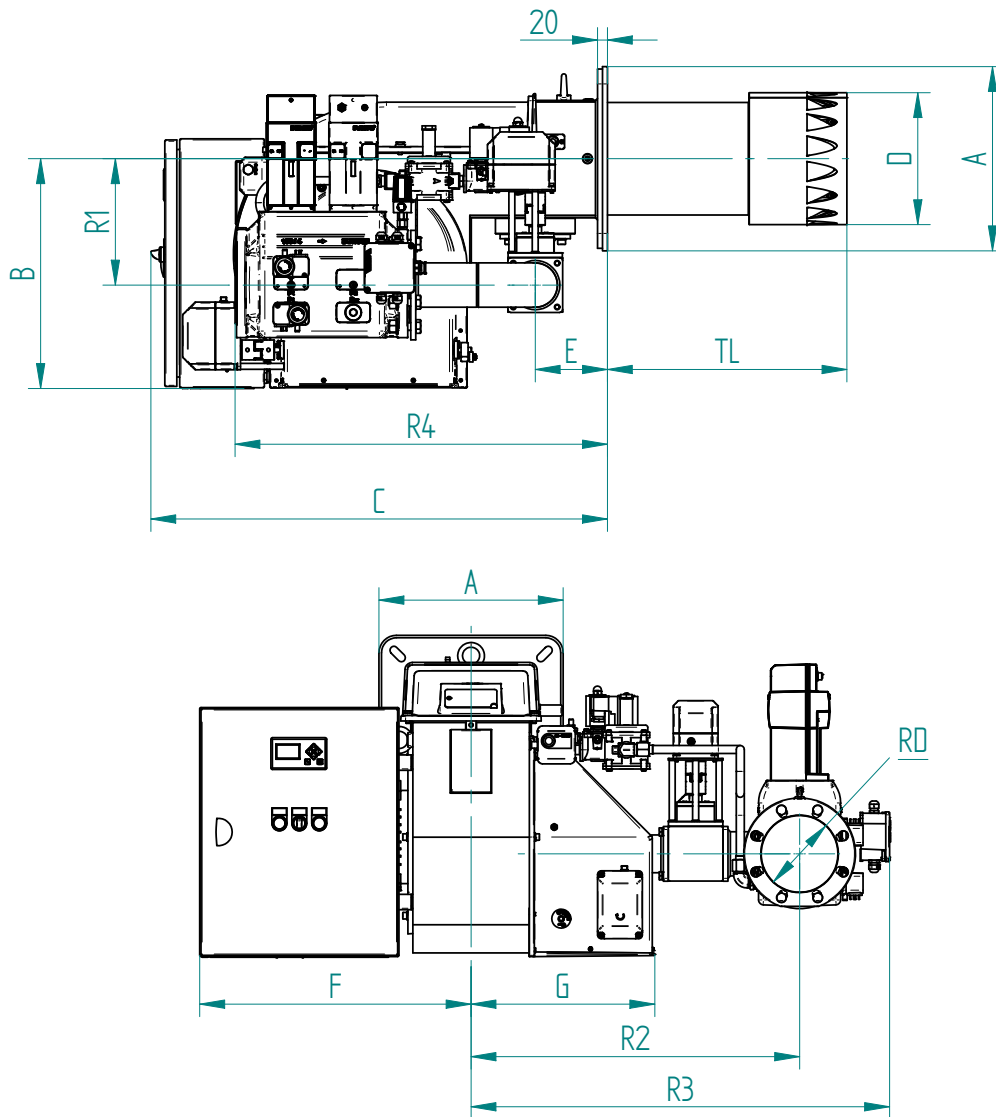
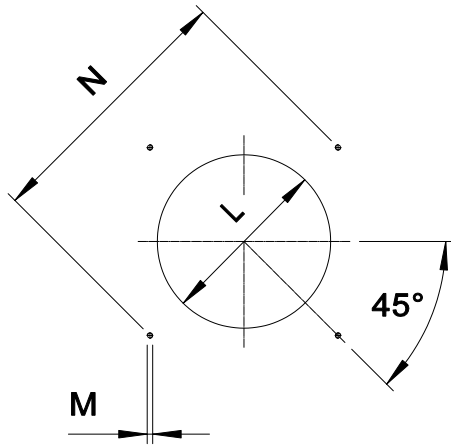

Fig. 3 Dimensions

MODEL	A	B	C	D	E	F	G	R1	R2	R3	R4	RD	Gas train weight
GAS P190/MCE-LX-EL - D2"-S-F50	360	461	917	265	145	545	369	254	626	761	870	Rp 2"	22 kg
GAS P190/MCE-LX-EL - DN65-S-F65	360	461	917	265	145	545	369	254	720	868	688	DN65	37 kg
GAS P190/MCE-LX-EL - DN80-S-F80	360	461	917	265	145	545	369	254	630	800	708	DN80	47 kg
GAS P190/MCE-LX-EL - DN100-S-F100	360	461	917	265	145	545	369	254	660	840	748	DN100	57 kg
GAS P250/MCE-LX-EL - D2"-S-F50	360	461	917	265	145	545	369	254	626	761	870	Rp 2"	22 kg
GAS P250/MCE-LX-EL - DN65-S-F65	360	461	917	265	145	545	369	254	720	868	688	DN65	37 kg
GAS P250/MCE-LX-EL - DN80-S-F80	360	461	917	265	145	545	369	254	630	800	708	DN80	47 kg
GAS P250/MCE-LX-EL - DN100-S-F100	360	461	917	265	145	545	369	254	660	840	748	DN100	57 kg
GAS P300/MCE-LX-EL - D2"-S-F50	360	461	917	300	145	545	369	254	626	761	870	Rp 2"	22 kg
GAS P300/MCE-LX-EL - DN65-S-F65	360	461	917	300	145	545	369	254	720	868	688	DN65	37 kg
GAS P300/MCE-LX-EL - DN80-S-F80	360	461	917	300	145	545	369	254	630	800	708	DN80	47 kg
GAS P300/MCE-LX-EL - DN100-S-F100	360	461	917	300	145	545	369	254	660	840	748	DN100	57 kg

BOILER PLATE



The dimensions of the boiler plate must be as indicated in the drawing.

* Suggested dimension of connection between burner and generator.

MODEL		L min	L *	L max	M	N min	N *	N max
GAS P190/MCE-LX-EL	mm	280	280	320	M14	396	424	438
GAS P250/MCE-LX-EL	mm	280	280	320	M14	396	424	438
GAS P300/MCE-LX-EL	mm	310	310	320	M14	396	424	438

FLAME TUBE LENGTH

Flame tube length must be selected based on the specifications supplied by boiler manufacturer and, in any case, it must be greater than the thickness of the boiler door included its insulation.

In case of boilers with flame inversion or front flue combustion chambers, it is necessary to insulate the area between the flame tube and front door with refractory material. This protection material must not impede flame tube extraction.

MODEL		TL**
GAS P190/MCE-LX-EL	mm	481
GAS P250/MCE-LX-EL	mm	481
GAS P300/MCE-LX-EL	mm	491

** For different flame lengths, please contact our Technical-Sales Department.



PRODUCT SPECIFICATION

SHORT DESCRIPTION

Burners for gas two stages progressive or modulating (PID fully modulating) if equipped with addition of optional modulation kit and probe low emissions in conformity with CE 676 class 3 (NO_x < 80 mg/kWh).

DETAILED SPECIFICATION

Burner for gas two stages progressive or modulating (PID fully modulating) if equipped with addition of optional modulation kit and probe; low emissions in conformity with CE 676 class 3 (NO_x < 80 mg/kWh), composed by:

- Fan at high pressurisation;
- Additional large diameter flange on the fan motor for easy extraction of the motor group + fan;
- Combustion head with adjustment at high performance and elevated flame stability equipped with steel blast tube and steel flame disc;
- Flange and insulating gasket for fixing at boiler;
- Three-phase power supply;
- Direct fan motor start;
- Burner terminal strip with terminal dedicated for 3ph/1ph power supply and for the connections to thermostats/boiler in-out signals;
- Burner electrical panel with: display with lock-out reset button, white led for power supply presence, green illuminated switch ON/OFF, green led for flame alight;
- Safety air pressure switch to stop the burner in lock-out in case of failed or anomalous fan operation;
- Gas train completely assembled and tested; complete of: working valve class A - safety valve class A - minimum gas pressure switch - gas valve proving pressure switch - filter;
- UV probe for flame detection;
- Pilot flame;
- IP 40 electric protection level;
- Spherical gas valve servo-controlled; progressive start and free way passage with total opening;
- Servomotor for air shutter and for the spherical gas valve;
- Moving shutter with total closure when idle in order to reduce at the least energy losses related to boiler cooling down;
- Easy extraction of combustion head without get off the burners by bolier;
- Maximum gas pressure switch to stop the burner in lock-out in case of the gas pressure is higher then the set point value;
- Set up for the additional specific kit that transforms burner operation as modulating i.e. the modulating kit allows to supply any power between the minimun and the maximum value based on instantaneous loading request.

CONFORMING TO:

- CE rules;
- 2014/30/UE Directive E.M.C.;
- 2014/35/UE Directive L.V.;
- 2006/42/CE - 2006/42/EG - 2006/42/EC Directive M.D.;
- Reference rules: EN676 (gas) - EN746-2 (industrial thermoprocessing equipment).

STANDARD EQUIPMENT

- Isomart gasket;
- Flange with insulating gasket;
- Burner nameplate;
- Warranty;
- Instruction handbook for installation, use and maintenance.



GAS BURNERS LOW NOX TWO STAGES PROGRESSIVE OR MODULATING WITH ELECTRONIC CONTROL BOX

SK073056_A_en

OPTIONAL

- Power modulating kits for temperatures;
- Power modulating kits for pressures;
- Kit for input 4-20mA / 0-10Vdc;
- Temperature probe 0°C-400°C (PT 100 a 0° C);
- Temperature probe 0°C-350°C (J probe);
- Temperature probe 0°C-1200°C (K probe);
- Pressure probe 0-3 bar, 0-6 bar, 0-16 bar, 0-20 bar, 0-30 bar;
- Sensors and system for O₂ control (is suggest to add the VSD);
- Sensors and system for CO control (is suggest to add the VSD);
- Sensors and system for O₂-CO control (is suggest to add the VSD);
- Modules for field BUS (modbus - profibus - profinet);
- Noise protection;
- Antivibration couplings;
- Handle gas taps.