

IGNITION TRANSFORMERS TYPES T8.. T16/D T18.. T20..

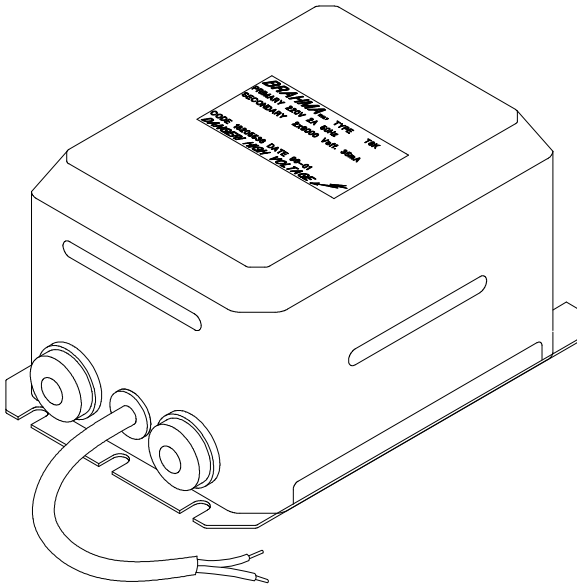

DESCRIPTION

The ignition transformers type T8... - T16/D - T18... - T20 have the same overall dimensions, but different electric features and fixing systems.

These transformers are used in different applications depending on their electric features, i.e.:

- The T8/... transformers are suitable for high thermal power burners or pressurised burners for light or heavy oil.
- The T16/D transformers are suitable for fluid or gaseous fuel burners.
- The T18/... transformers, which are designed for permanent operation, are suitable for the application on industrial machines (e.g. water cleaners).
- The T20/... transformers are suitable to equip light or heavy oil burners designed for frequent and repeated starts (e.g. burners for steam boilers, cooking furnaces, and so on).

FEATURES

Followings are the main features of this series:

- various connection and fixing systems;
- high discharge power;
- high efficiency and ignition power.

TECHNICAL DATA

- **Supply voltage:** 220V - 50Hz
(different voltage and frequency values are available on request)
- **Operating temperature range:** -10°C +60°C
- **Isolation:** polyester resin
- **Recommended distance between the electrodes:** 3÷5mm
- **Supply cable standard length:** 700 mm

	T8/...	T16/D	T18/...	T20/...
Number of poles	2	2	2	2
Output peak voltage (KV)	2 x 6.5	2x5	2 x 4.5	2 x 5
Output effective current (mA) (1)	35	20	16	23
Input effective current (A)	2.1	1,1	0.77	1.3
Duty cycle	33% in 3 minutes	33% in 3 minutes	100%	66% in 3 minutes
Power consumption (VA)	460	240	170	285
Weight (Kg)	3.5	30	3.7	3.2

(1) : short circuit secondary.

CONSTRUCTION

This series consists of column-type transformers, i.e. ignition transformers fitted with 2 primary windings and 2 secondary windings, except for type T16/D which is a shell-type transformer. All types are isolated by a special high isolation separator. High voltage isolation is achieved by means of a special kind of vacuum cast polyester resin.

The housing is made of stove enamelled pressed metal. Each transformer is specified by the letter T (transformer), by one or more figures indicating the model and sometimes by some letters referring to the particular fixing system, i.e.:

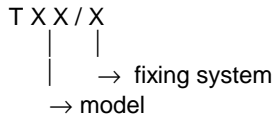

If the fixing system used is standard, the corresponding reference letter is not inserted in the part reference. For instance, the part reference T8 refers to a transformer with standard fixing system, whereas the part reference T8/B corresponds to a T8 transformer with different fixing system (see Fig.1, type B). The transformers of this series can have the same electric features but different fixing systems, or vice versa.

OVERALL DIMENSIONS

Fig.1 shows the main overall dimensions and the various fixing systems of these transformers.

CONNECTION

The high voltage isolators employed in this series of transformers are of two different types (see Fig.2), according as the connection with high voltage cables occurs by means of a screw or of a 6.3 diameter cylindrical terminal type Rajah. If not expressly mentioned, the connection terminal used is a screw terminal. Both isolators are made of ceramic.

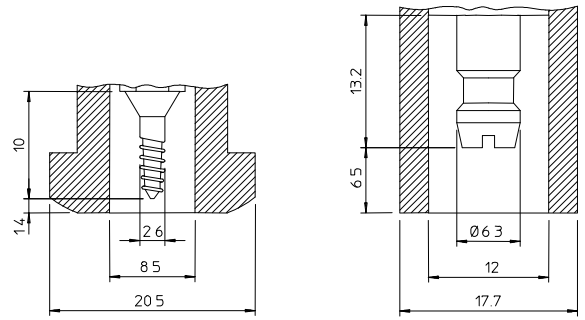

Fig.2

INSTALLATION

- Connect and disconnect the ignition transformer only after switching off the power supply.
- Respect the applicable national and European standards (e.g. EN 60355-1 / EN 50165) regarding electrical safety.
- Make sure that the earth of the transformer and the earth of the electric system are well connected.
- The device can be mounted in any position.
- Do not put high voltage cables next to other cables.
- Guarantee a protection degree suitable to the application.

Fig.1

