

**ELECTRONIC IGNITION  
TRANSFORMERS FOR  
INTERMITTENT OPERATION  
SUPPLIED BY LOW VOLTAGE**

**TC2...A Series**

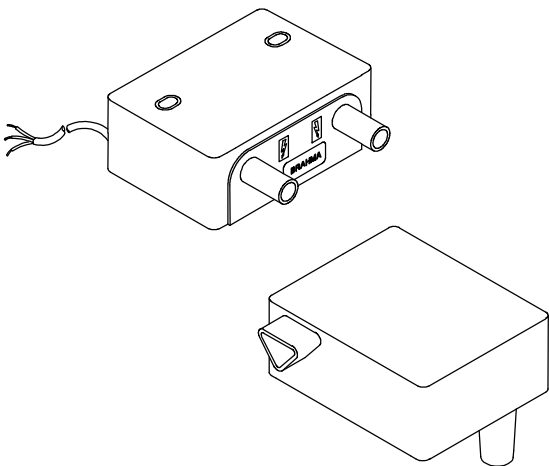

**TD2...A Series**

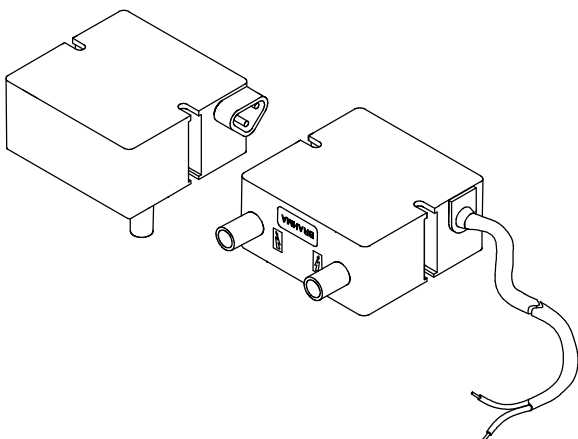

**DESCRIPTION**

These ranges of electronic ignition transformers are characterized by extremely limited overall dimensions and are particularly suitable to equip forced draught burners for gas and light or heavy oil, for civil and industrial applications.

The working principle is based on a high frequency electronic oscillator; the voltage it generates is then increased by using a transformer with ferrite nucleus, reaching in this way output voltage values up to 12 kV.

**FEATURES**

The main features are the followings:

- 50% duty cycle in 2 minutes;
- limited weight and overall dimensions;

	TC2...A TD2...A
	24 V DC/AC
Number of poles	2
Output peak voltage kV (1)	2 x12
Rated output voltage kV(4)	2 x 5
Output peak current mA (2)	35
Rated output current mA (2)	24
Output voltage frequency kHz (1)	7
Output voltage frequency kHz (2)	14
Consumo (3)	63 W ( 24 VDC ) 45VA ( 24 VAC )

- (1) No-load output and 30 pF load
- (2) Short circuito output.
- (3) 10 mm spark gap.
- (4) No-load output.

- different fixing and connecting systems
- inbuilt protection against short circuit;
- **in oil and gas burner , the safety of ignition transformers depends on the control unit.**

**TECHNICAL DATA**

- **Supply voltage:** 24VDC e 24VAC
- **Duty cycle:** 50% in 2 minutes
- **Operating temperature range:** -10°C +60°C
- **Protection degree:** IP00
- **Winding class:** H
- **Recommended distance between the electrodes::** 3÷5 mm
- **Max. ignition cable length:** 1.5 m
- **Standard supply cable length:** 560mm
- **Weight:** TC series 420g approx.  
TD series 360g approx

## CONSTRUCTION

The working principle based on the use of a high frequency electronic oscillator has enabled to develop a device with limited dimensions and weight, but with high ignition power.

The electronic circuit and the transformer with ferrite nucleus are bathed in a special kind of resin with very good thermal conductivity and a specific coefficient of expansion, which ensures high resistance to temperature variations and to the overload due to protracted working.

The transformers of these series are available in different versions as regards the position of the isolators, the type of connection, the power supply connection; on this subject, see the following scheme:

### TC/TD 2 X X X A

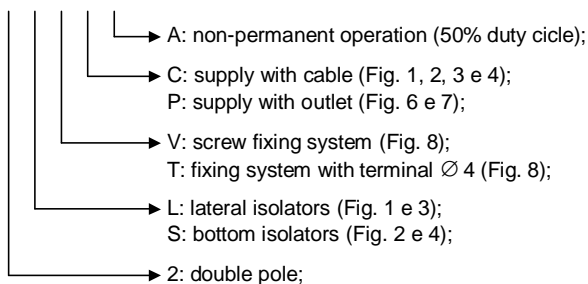

For instance, the designation TD2LTPA indicates that the transformer is provided with two lateral isolators, screw fixing system, power supply with outlet, and is for non-permanent operation.

## OVERALL DIMENSIONS

The TD series differs from the TC series for its more reduced overall dimensions; Fig.1, Fig.2, Fig.3 e Fig.4 show the main dimensions of both transformer series.

To fix the transformer screw type M4 or M5 should be used; (in the transformer of the TC series, the oval holes enable a variation of the fixing wheel base between 57 mm and 64 mm).

### TC2L

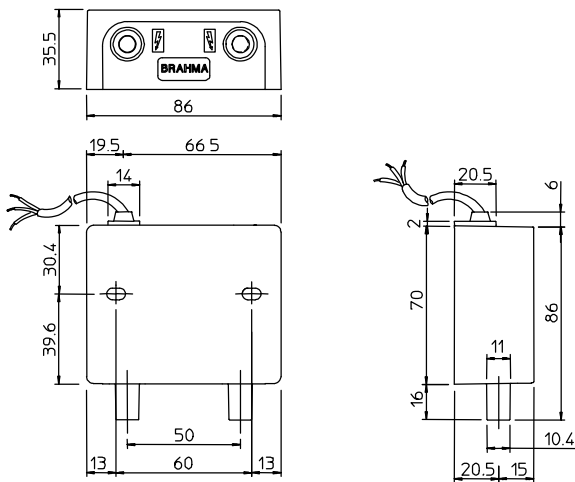

Fig. 1

### TC2S

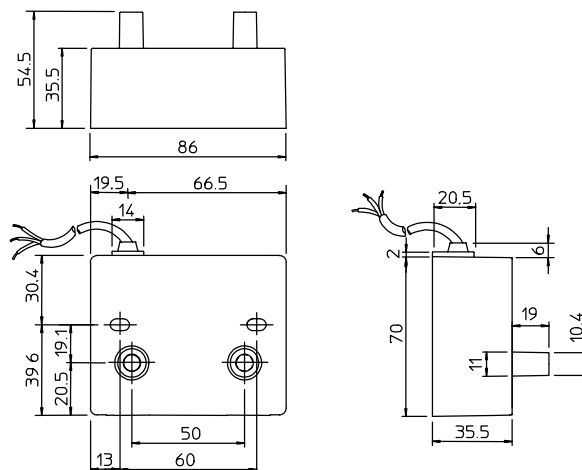

Fig. 2

### TD2L

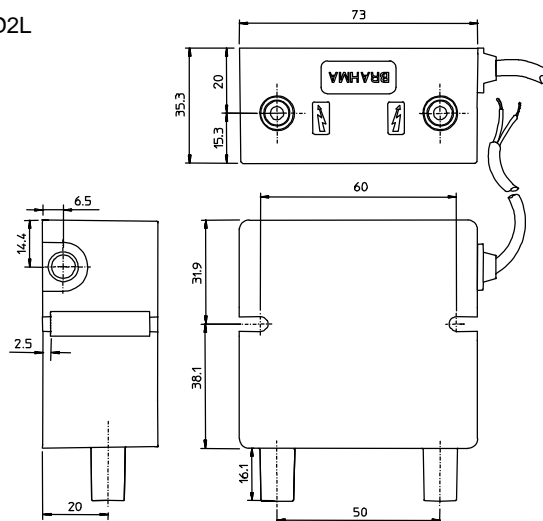

Fig. 3

### TD2S

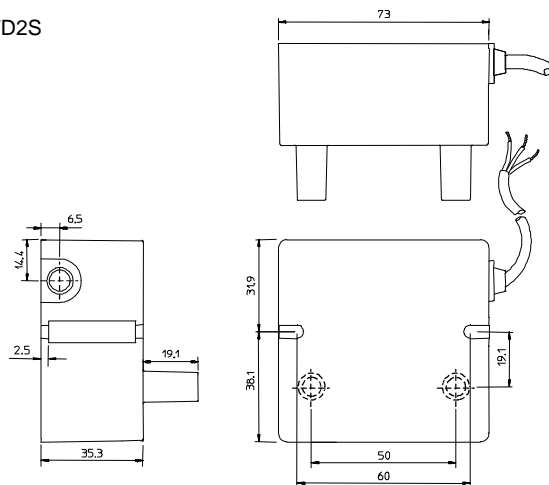

Fig. 4

## CONNECTION

These ranges of ignition transformers have been developed in order to be used with control boxes of our own production, which can be mounted on the ignition devices by means of fixing screws type M4x45, as shown in Fig. 5.

All transformers can be supplied with cable or supply outlet; see, for instance, Fig. 6 and Fig. 7, which show the dimensions of a transformer provided with supply outlet (with laterals isolators).

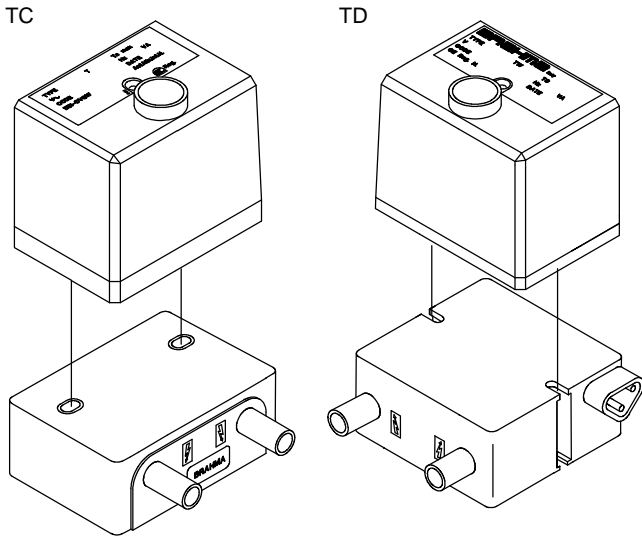
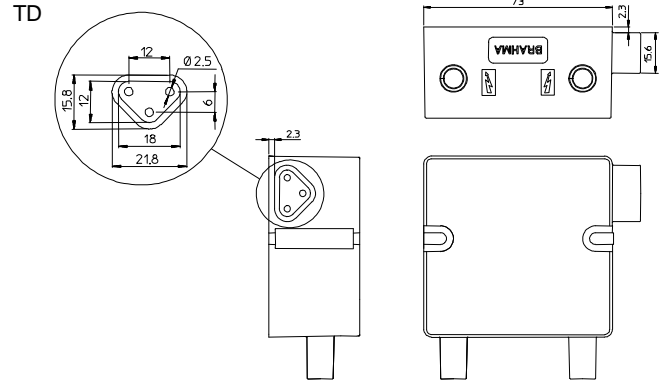
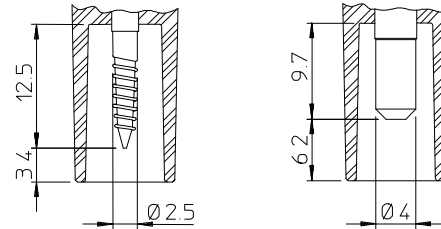

Fig. 5



The connection of high voltage cables can be of two types, according to the terminals used inside the isolators: connections can be carried out by means of a screw or a cylindrical terminal with 4 mm diameter, as shown in Fig. 8. All connectors, including the ones complete with cable, can be supplied on request.



Type "V"

Type "T"

Fig. 8

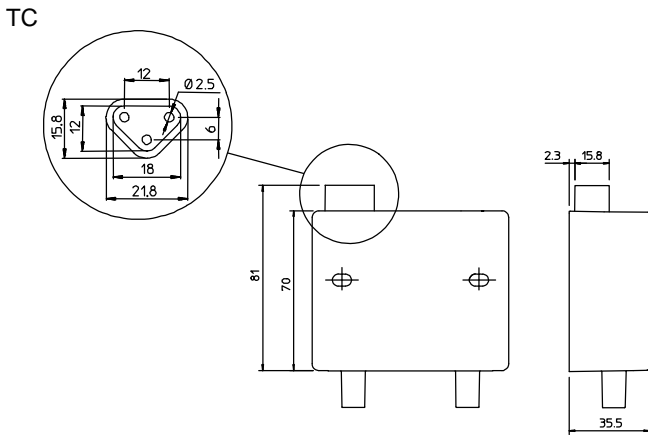

Fig. 6

## INSTALLATION



- Caution! There might be dangerous voltages.
- Connect and disconnect the ignition transformer only after interrupting the main supply.
- Respect the applicable national and European standards (e.g. EN 60355-1 / EN 50165) regarding electrical safety.
- Make sure that the earth of the ignition transformer and the earth of the electrical system are well connected.
- The device can be mounted in any position.
- Avoid putting high voltage cables next to other cables.
- Ensure a protection degree suitable to the application.

Fig. 7