

# EN331

1/4" - 4" EN 10226-1



## HIGH TEMPERATURE RESISTANCE

Now approved for **HTB** use (Hochtemperaturbeständigkeit)  
Class B 0,1 (0,1 bar @650°C for at least 30 minutes).



## Quality

- 24h 100% seal test guaranteed
- Dual sealing system allows valve to be operated in either direction making installation easier
- No metal-to-metal moving parts
- No maintenance ever required
- Handle clearly shows ball position
- Silicone-free lubricant on all seals
- Handle stops on body to avoid stress at stem
- Chrome plated brass ball for longer life with rinse hole

## Body

- Hot forged sand blasted external nickel plated brass body and cap sealed with Loctite® or equivalent thread sealant
- Finest brass according to EN 12165 and EN 12164 specifications

## Stem

- Blowout-proof nickel plated brass stem
- Maintenance-free, double FPM O-rings at the stem for maximum safety

## Sealing

- Pure PTFE self-lubricating seats with flexible-lip design

## Threads

- EN 10226-1, ISO 228 parallel female by female threads

## Upon request

- Stainless steel ball (1.4401/AISI 316)
- Glass filled PTFE seals
- Custom design

## PED directive

- Assessment according to Pressure Equipment Directive 2014/68/UE module B+D by ICIM (0425)

## Flow

- Full port to DIN 3357 for maximum flow

## Handle

- Geomet® carbon steel handle with thick PVC dip coating. Handle coating offers both thermal and electrical protection
- **WARNING:** do not exceed reasonable temperature and/or electrical load
- Handle removable with valve in service

## Working pressure & temperature

- 40 bar (600 PSI) up to 2", 30 bar (450 PSI) over 2" non-shock cold working pressure
- -40°C to +170°C (-40°F to +350°F)
- For use with dangerous fluids temperature rating is -20°C +60°C and pressure rating is 5 bar / **HTB** Class B 0,1
- AS4617 Limitation for GAS: 2100 Kpa up to 2" and 1500 Kpa from 2.1/2" to 4" rated working pressure and 0°C/ +60°C temperature
- **WARNING:** freezing of the fluid in the installation may severely damage the valve

## Options up to 2" size

- Stem extension
- T-handle
- Stainless steel handle (1.4016 / AISI 430)
- Taper male by parallel female threads up to 4"
- Oval lockable handle up to 2", round over 2"
- Patented locking device for valves up to 4"
- Stubby handle
- **RuB** memory stop designed to be installed with our stubby handle

## Approved by or in compliance with

- The Australian Gas Association (Australia)
- Factory Mutual (United States)
- SVGW (Switzerland)
- GOST-R (Russia)
- EAC - Declaration of conformity (Russia, Kazakhstan, Belarus)
- BSI Group (United Kingdom)
- RoHS Compliant (EU)
- DIN-DVGW (Germany) - MOP 5 B 0,1
- ARGB-KVBG (Belgium) - MOP 5 bar for outside building gas installation, MOP 100 mbar for inside the buildings

**NOTE:** approvals apply to specific configurations/sizes only.



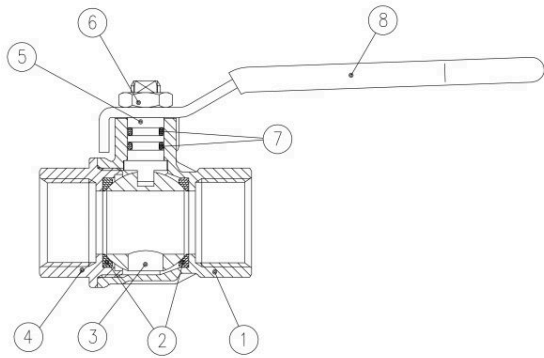

	PART DESCRIPTION	Q.TY	MATERIAL
1	Nickel plated body (external nickel plated, unplated inside up to 2")	1	CW617N
2	Seat	2	PTFE
3	Chrome plated ball with rinse hole (read rinse hole on sizes from 3/4" up to 2")	1	CW617N
4	Nickel plated end-cap (external nickel plated, unplated inside up to 2")	1	CW617N
5	Nickel plated stem O-ring design	1	CW617N
6	Geomet® nut	1	CB4FF (EN10263-2)
7	O-Ring	2	FPM
8	Yellow PVC coated Geomet® steel handle	1	DD11 (EN10111)

1.1/4" - 2" hollow ball

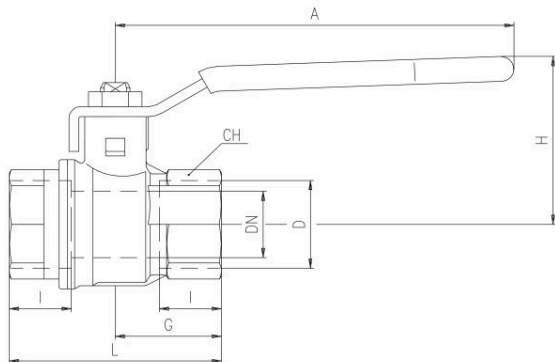

DN shows the nominal flow diameter. Actual flow diameter complies with full port DIN 3357 part 4. Stem configuration of valves over 2" is slightly different. Ball valves are marked CE on handle from 1.1/4" to 2", on body over 2" as follow: CE 0425 cat IIIB+D PS: 5 GAS TS1: -20°C TS2: +60°C

Compliant to  
 2014/68/UE product  
 Equipment category III Module B+D

D (Inch)	1/4	3/8	1/2	3/4	1	1 1/4	1 1/2	2	2 1/2	3	4
DN (mm)	8	10	15	20	25	32	40	50	65	80	100
I (mm)	12	12	15.5	17	21	23	23	26.5	32	35	41.5
L (mm)	45	45	59	64	81	93	102	121	156	177	216
G (mm)	22.5	22.5	29.5	32	40.5	46.5	51	60.5	78	88.5	108
A (mm)	82	82	100	120	120	158	158	158	255	255	255
H (mm)	38	38	43	50	54	73	79	86	132	140	154
CH (mm)	20	20	25	31	40	49	54	68.5	85	99	125
Kv (m <sup>3</sup> /h)	3.9	8.2	28	36	62	79	124	178	516	776	1130

Pressure-temperature chart

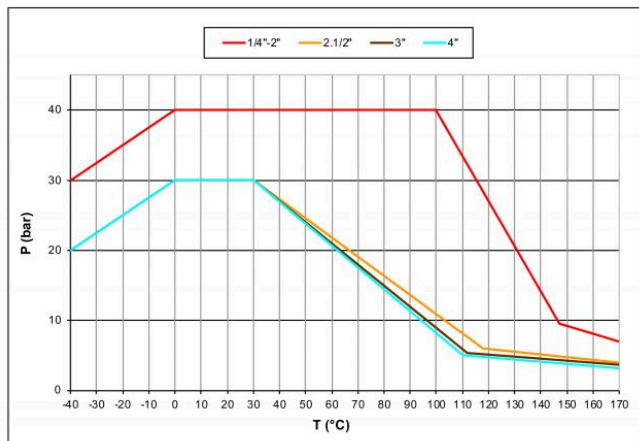

AS4617 limitations for GAS: 2100 Kpa up to 2" and 1500 Kpa from 2. 1/2" to 4" rated working pressure and 0°C +60°C temperature

Pressure drop chart

