

MICROFLAT SERIES TYPES CM32PR CE32PR

**AUTOMATIC CONTROL SYSTEMS WITH
MANUAL AND ELECTRIC RESET FOR
PRE-MIXED GAS BURNERS AND
INSTALLATIONS (PROVIDED WITH FREE
TERMINALS FOR AN EXTERNAL
IGNITION DEVICE)**

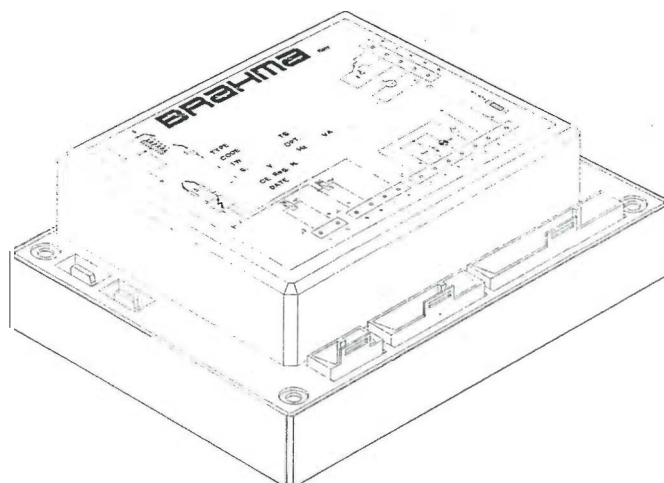

APPLICATION

This range of electronic gas burner control systems has been specifically designed for atmospheric pre-mixed gas burners for intermittent operation (systems for non-permanent operation).

The control unit type CM32PR is provided with non-volatile lockout, i.e. the restart from the safety shutdown condition can only be accomplished by a manual reset of the system.

The control unit type CE32PR is provided with volatile lockout, i.e. a restart from the lockout condition can be accomplished by an interruption of the mains power supply and its subsequent restoration or by means of the heat demand to the control.

The automatic burner control units of this series are suitable for:

- combi boilers (only type CM32PR);
- heating boilers (only type CM32PR);
- water heaters.

These controls are provided with free terminals for an external ignition device (selected the appliance manufacturer). As a result, these controls can be used for applications where ignition is particularly difficult, thus avoiding the use of pilot valves and hot surface ignitors.

To reduce the electromagnetic interference produced by ignition devices, these control units can be fitted with our electronic ignition transformers type TC1AF-TC2AF with inbuilt E.M.C. filter (see technical sheets about "Electronic ignition transformers").

FEATURES

TABLE 1 shows the main features of this series. Other important features are:

- EC certification type (CE Reg. N° 63AT1990) in accordance with the European Gas Directive Appliance 90/396/EEC amended by 93/68/EEC; in compliance with EN 298 (European standard for automatic gas burner control systems and flame detectors for gas burners); output for the control of the ignition device by means of supply voltage; possibility of mounting a resistor (0 ± 220 ohm) in series to the valve outputs, in case the valves operate with direct current obtained through the rectification of the supply alternate current by means of one or more diodes;
- for non-volatile lockout versions, possibility of mounting a resistor (0 ± 470 Kohm) in series to the lockout signal output, to avoid possible damages to the control in case the connections of the reset push-button and the connections of the lockout signal are reversed;
- two independent safety contacts in series on the gas valve output;
- flame monitoring by the rectification property of the flame (ionization).

TABLE 1

	Burner	Features		Option	classification code according to EN298 (2)
	dual flame	non-volatile lockout	volatile lockout	connectors type molex (1)	
CM32PR	*	*		*	FTCLXN
CE32PR	*		*	*	FTCVXN

(1): Standard connectors are Stocko-Stelvio models, see Fig.2.

(2): Flame failure during TS causes spark restoration.

TECHNICAL DATA

Supply Voltage:	220-240V/50-60Hz
on request:	110-120V/50-60Hz
Operating temperature range:	-20°C +60°C
Ambient humidity:	95% max at 40°C
Protection degree:	IP 00

Times:

- Prepurge time (TW):	1,5 ... 40 s
- Safety time (TS):	3 ... 120 s
- Drop out time on running flame failure:	< 1 s

The times given on the burner control label correspond to the values guaranteed. The actual values slightly differ from the values given, as prepurge can be longer and safety time shorter than their nominal values.

Starting power consumption: 4VA

Operating power consumption: 9VA

Contact rating:

-Thermostat:	4 A $\cos \varphi \geq 0.4$
-VG1:	0.5 A $\cos \varphi \geq 0.4$
-VG2:	0.5 A $\cos \varphi \geq 0.4$
-Fan:	1 A $\cos \varphi \geq 0.4$
-Ignition device:	1 A $\cos \varphi \geq 0.4$
-Alarm:	1 A $\cos \varphi = 1$

Max. length of the cables of external components:

1m

Internal fuse rating: 4 A quick acting

Flame control:

The ionization flame detection device makes use of the rectification property of the flame.

This device is not provided with any protective impedance, therefore the detection probe is not safe against the risk of electric shock.

-Minimum ionization current: 0.5 μ A
on request: 1.2 μ A/2.5 μ A

-Recommended ionization current: 3 + 5 times the minimum ionization current

-Max. length of the cable: 1m

-Minimum insulation resistance of the cable and the flame detection device to earth: $\geq 50M\Omega$

-Max. stray capacitance of the detection probe: $\leq 1nF$

-Max. short circuit current: < 200 μ A AC

Weight: 155 g

CONSTRUCTION

The enclosure made of plastic material and the varnishing of the printed circuit board protect the control from mechanical

damages resulting from crashes, incautious opening, dust and contact with the external environment.

Through the use of a board assembled with surface mounted components it has been possible to reduce the printed circuit board dimensions and to realize even the most complex executions with extremely compact overall dimensions.

A varistor protects the control from possible voltage transient in the electric network, caused for example by discharges such as thunderbolts. An inbuilt fuse protects the control box in case of short circuit on the outputs (valves, fan, ignition device and lockout signal).

OVERALL DIMENSIONS

The control units of the MICROFLAT series can be supplied in different executions but with the same enclosure. The following figure (Fig. 1) shows the overall dimensions of the controls.

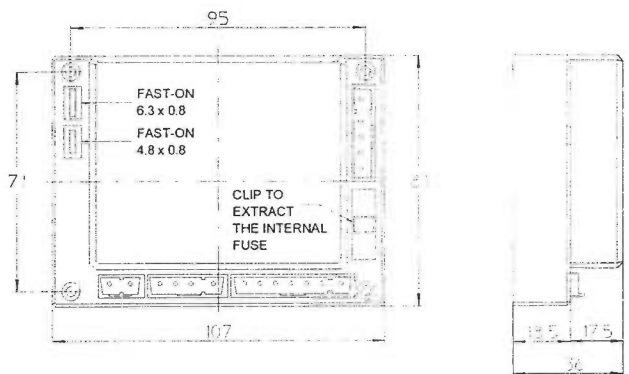

Fig.1

POSSIBLE FIXING SYSTEMS

top: self-tapping screw UNI6951AB 2.9x22
M3x22 screw UNI6107

bottom: screwplast self-forming screw ISO0003 F 3.5x13
screwplast self-forming screw ISO0003 F 3.9x13

ACCESSORIES

The control units can be supplied complete with connectors and light reset push-button (see Fig.2 and Fig.3); in a case do not fit terminals and female connectors of different types.

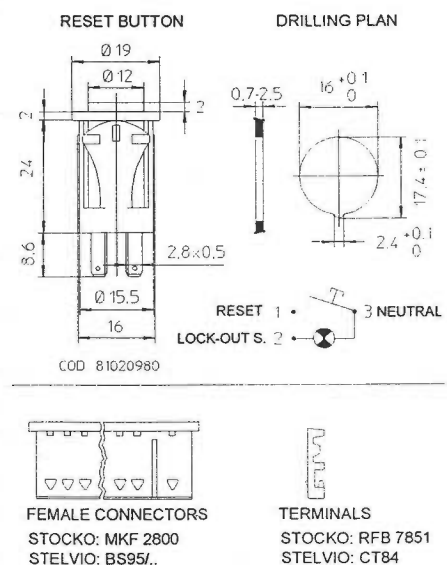

Fig.2

FEMALE CONNECTORS
MOLEX: SERIE 3001

TERMINALS
MOLEX: 2478

Fig.3

CONNECTION

The use of non reversible connectors with a different number of poles makes the connection easy and reliable. One-way fast-on connectors of different sizes for detection electrodes and earth connection enable an easy installation and replacement.

The one-output ignition device allows spark generation on one point (4a), whereas the dual-output ignition device enables spark generation on two points (4b) or between two electrodes isolated from the metal frame of the burner (4c), see Fig.4. The configuration (4c) ensures a more reduced emission of electromagnetic interference.

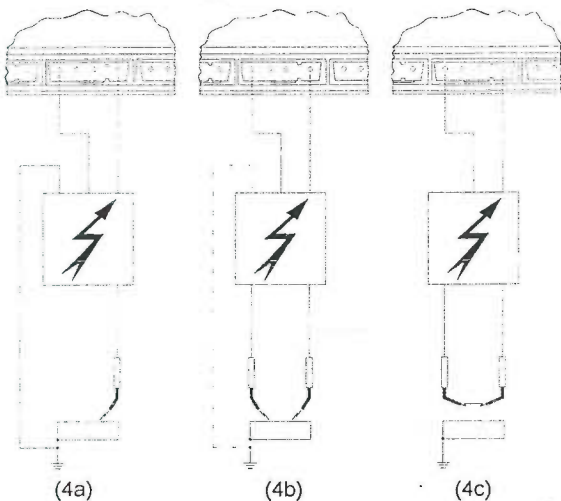

Fig.4

Provisions such as strain relieves, sufficient earth terminals and neutral terminals have to be available in the appliance or in external connection boxes.

DIRECTIONS FOR USE

- Automatic controls are safety devices and must not be opened. The manufacturer's responsibility and guarantee are invalidated if the control is incautiously opened.
- For technical safety reasons a regulation shutdown must occur every 24 hours (systems for non-permanent operation).
- The control can be connected and disconnected only after switching off the power supply.
- The control can be mounted in any position.
- Avoid exposing the control unit to dripping water.
- Ventilation and the lowest temperature ensure the longest life of the control.
- Make sure that the type (part number and times) you are using is correct before installing or replacing the control.
- The gas appliance in which the control is installed must provide adequate protection against the risk of electric shock (at least IP20).

ELECTRICAL INSTALLATION

- The applicable national and European standards (e.g. EN 60335-1/EN 50165) regarding electrical safety must be respected.

- Live and neutral must be connected correctly; a mistake could cause a dangerous situation, i.e. the internal and external protection and safety devices could be ineffective in case the connection cables of thermostats and valves should lose their isolation. If live-neutral polarity is not respected the control goes to lockout at the end of safety time.
- Before starting the system check the cables carefully. Wrong connections can damage the control and compromise the safety of the installation.
- The earth terminal of the control, the metal frame of the burner and the earth of the electric system must be well connected.
- Avoid putting the detection cable close to power or ignition cables.
- Use heat resistant detection cables and probes, well insulated to the ground and protected from humidity or water in general.
- Use an ignition and isolation cable as short and straight as possible and keep it far from other conductors to reduce the emission of electromagnetic interference.

In case of leakage between live and earth the voltage on the ionization probe can be reduced until it causes the lockout of the control, because of the impossibility of detecting the flame signal.

CHECKING AT START

Always check the control before the first start and also after any replacements or a long period of non-operation of the system. Before any ignition attempt make sure that the combustion chamber is free from gas.

Then make sure that:

- if the starting attempt occurs without gas supply the control goes to lockout after safety time;
- when stopping the gas flow while the control is working, the supply to the gas valves is interrupted within 1 second and after a recycling the control proceeds to lockout;
- operating times and sequence are suitable for the control box used;
- the level of the flame signal is high enough (see Fig.5 for the measuring test);
- the ignition probes are conveniently adjusted;
- the intervention of adjusters, limiters or safety devices causes a safety shutdown according to the application.

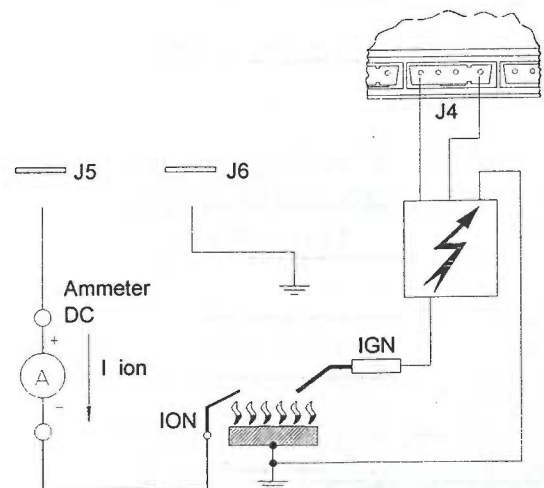

Fig.5

OPERATION

At every start the control unit proceeds to a self-checking of its own components. During prepurge time (TW) the operation of the flame signal amplifier is checked: a parasitic flame signal or a fault in the amplifier leading to the same condition prevent the control from starting.

Before the beginning of prepurge time the air pressure switch contact is checked to prove its "no air flow" state.

Only if the test is positive is the pressure switch started, causing in this way the beginning of prepurge time.

During prepurge time in the control unit type CE32PR the lockout signal is switched on.

At the end of the prepurge time the VG1 gas valve is energized and the external ignition device is operated. In this way safety time (TS) begins. If a flame signal is detected during safety time, the ignition device is inhibited and the main valve (VG2) is energized.

On the contrary, if no flame signal is detected during safety time, the control unit proceeds to lockout, the VG1 gas valve and the ignition device are switched off, while the lockout signal is supplied.

Flame failure during safety time causes the ignition device to be re-activated within one second.

The attached operating cycle diagrams are useful to understand how each control operates.

RESET OF THE CONTROL UNIT

When using the control unit type CM32PR with non-volatile lockout, a delay of at least 10 seconds has to be allowed before attempting to reset the unit; if this delay is not observed the system could not reset.

When using the control unit type CE32PR with volatile lockout, the reset from lockout is achieved by means of interruption of the electrical supply and its subsequent restoration. It is also possible to reset the control by means of the heat demand.

As this control box type is not provided with independent manual reset, therefore its use is restricted to the applications in which resetting by switching off the heat demand is allowed by the European standards.

In the application, it is allowed to use the main switch of the appliance to reset the burner control. In such a case, the alarm light of the control needs to be installed also.

In general, resetting of the appliance shall occur in sight and in the near vicinity of the appliance. Resetting has to be accomplished by means of a conscious manual action and not by means of any automatic devices such as thermostats or timers.

CONTROLS DENOMINATION

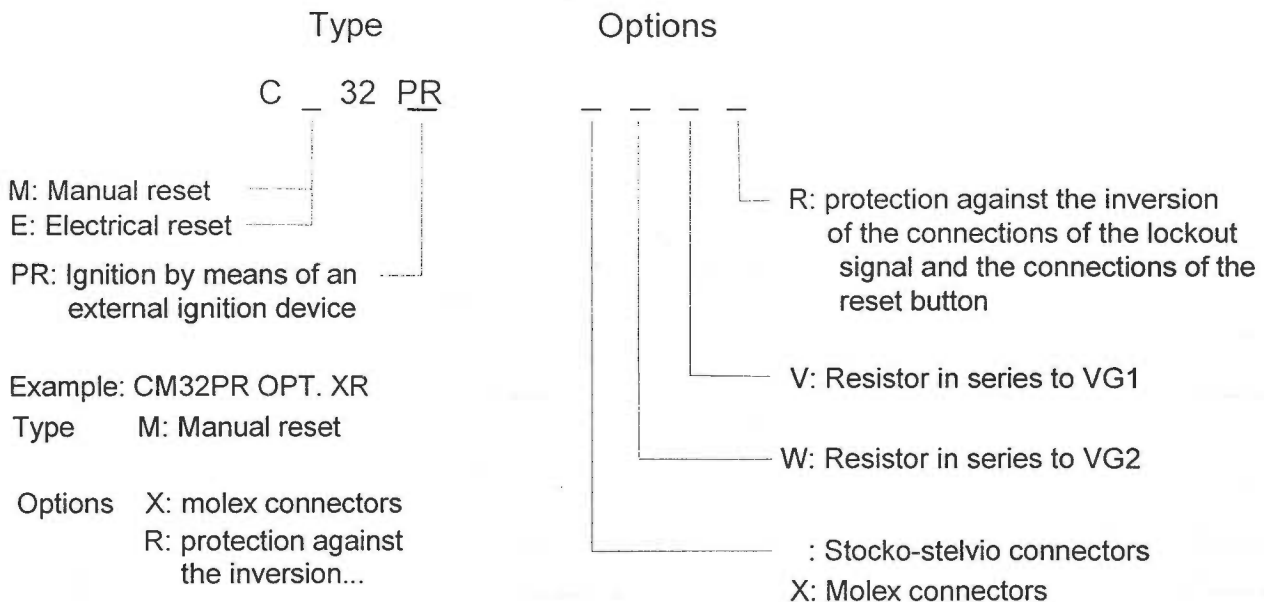

CONNECTION DIAGRAMS

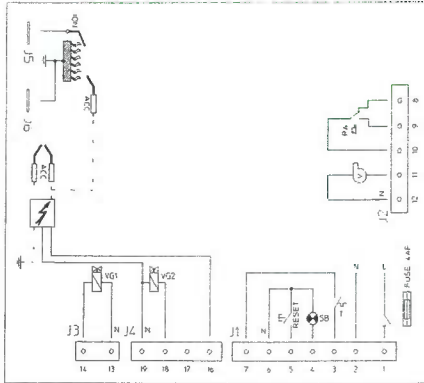

TYPE CM32PR

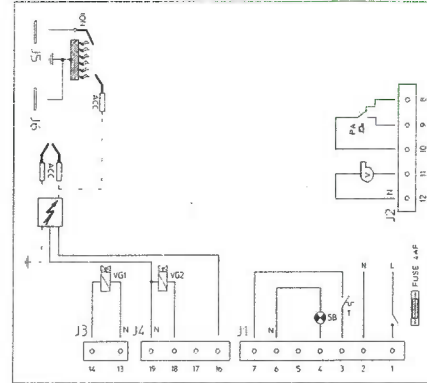

TYPE CE32PR

NOTE: the limit thermostat has to be wired in series with the live conductor of the mains supply.

OPERATING CYCLES

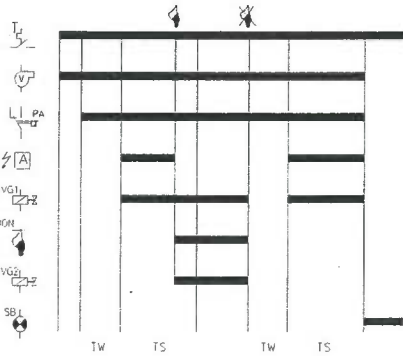

TYPE CM32PR

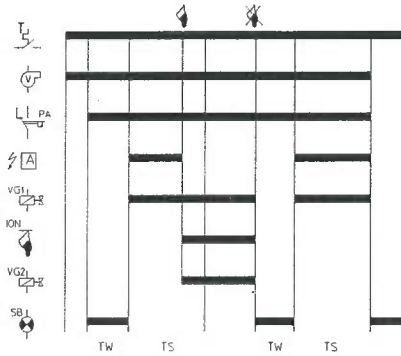

TYPE CE32PR

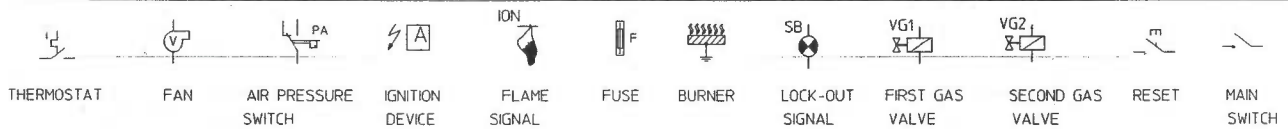

Microflat Series
Types CM32PR CE32PR