

# EURO-OIL SERIES

## TYPE G22 series 09

### AUTOMATIC OIL BURNER CONTROL SYSTEMS

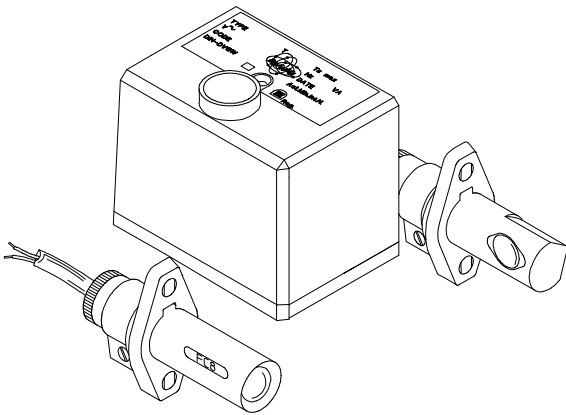

#### APPLICATION

This range of electronic oil burner controls has been specifically designed for oil burners for non permanent operation.

The automatic burner controls of this series are suitable for:

- monobloc oil burners
- warm air generators
- steam boilers
- power washers
- kilns

Due to the technical and structural characteristics and to the variety of models they can be used for the automation of cookers and oil burner operated appliances for domestic and industrial applications.

#### FEATURES

The G22 series 09 oil burner controls, simple wiring and installation. The main features of this series are following:

- for non permanent operation;
- for one-stage oil burners (single flame);
- prearranged for appliances with pre-heater (see “CONNECTION DIAGRAMS”);
- maximum heat input according to the European standard EN 267:1999-09:
  - $\leq 30$  kg/h (max. ignition safety time 10 seconds)
  - $> 30 \leq 100$  kg/h (max. ignition safety time 5 seconds)the pre-purge time has to be set in compliance with nominal fuel throughput of the burner;
- in accordance with the European standard DIN EN 230:1991-05 concerning monobloc oil burners, safety control and regulation devices. The DIN registration number relevant to this series of devices is the following:  
**5F165/04**
- in compliance with the standard DIN 4794 part 2, edition December 1980 regarding warm air generators WLE (only version with TV = 20s and TS = 5s);
- operation with flame detector type FC7/FC8;
- two independent safety contacts for oil valve(s) control;
- electrical service life at max load  $>250.000$  operations;
- simple wiring and installation.

**TECHNICAL DATA**

**Supply Voltage:** 220/240V 50/60Hz  
 on request: 110/120V 50/60Hz  
**Operating temperature range:** -20°C +60°C  
**Ambient humidity:** 95% max at 40°C  
**Protection degree:** IP 40

**Times**  
 - Pre-purge time (TV) 1,5/10/20/30/40 s  
 - Ignition safety time (TS) 5/10 s  
 - Dropout time on running flame failure: < 1s

The times given on the burner control label correspond to the values guaranteed. The actual values slightly differ from the values given, as prepurge time can be longer and safety time shorter than their nominal values.

**Power consumption:** 8 VA

**Contact rating:** I max  
 - Thermostat: 6.0 A cosφ > 0,4  
 - Motor: 2.0 A cosφ > 0,4  
 - Ignition transformer: 2.0 A cosφ > 0,4  
 - EV1: 0.5 A cosφ > 0,4  
 - EV2: 0.5 A cosφ > 0,4  
 - Pre-heater: 0.5 A cosφ = 1,0  
 - Alarm: 1.0 A cosφ = 1,0

**Internal fuse rating:** 6.3 A slow blow

**External fuse rating:** 4.0 A fast

**Weight (including socket):** 132 g

**CONTROLS FOR SPECIAL APPLICATIONS**

On request it is possible to meet special requirements concerning times and operating cycles.

**CONSTRUCTION**

The particular construction and the use of the surface mounted components allow to have reduced overall dimensions.

The enclosure made of plastic material protects the control from possible damages resulting from crashes, incautious opening, dust and contact with the external environment. A varistor protects the control from voltage transients on the electric network.

An inbuilt fuse protects the internal relays of the control box in case of short circuit on the outputs (valves, ignition transformer, motor and lockout signal).

**OVERALL DIMENSIONS**

The following figure (Fig.1) shows the overall dimensions of the control.

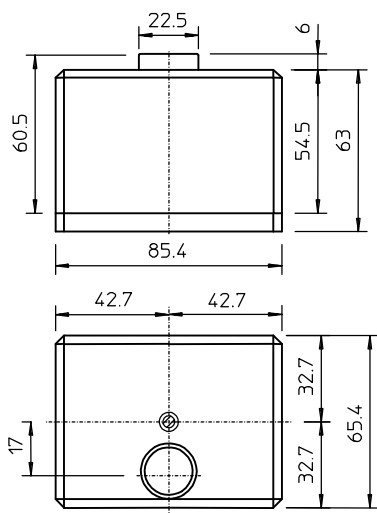

Fig.1

**CONNECTION**

For the connection of the external components the control box is delivered with socket type N (see Fig. 2). The socket is provided with a screw terminal board which allows a simple

and reliable connection. To fix the socket it is advisable to use screws type M4. To fix the control to the socket use the pin supplied with the control box.

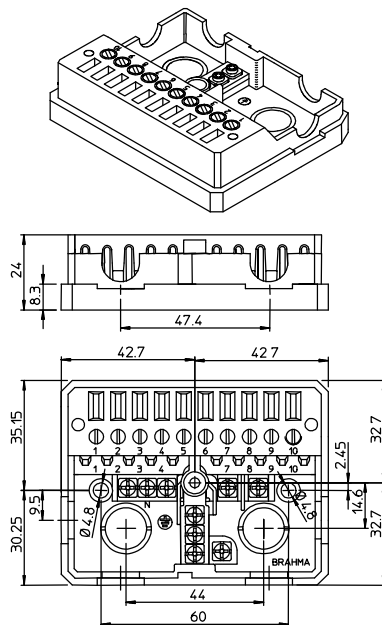

Fig.2

For the electrical connection of the external devices see "CONNECTION DIAGRAMS".

**ACCESSORIES**

The following data are useful to choose the most suitable flame detector for the appliance and the control box used:

- for traditional burners (yellow flame burners) the following photocells are suitable:

	FC8/R	1,5..5,5 lux
frontal side	FC8/A	1,5..3,0 lux
	FC8/V	3,0..5,5 lux

	FC7/R	1,5..5,5 lux
lateral side	FC7/A	1,5..3,0 lux
	FC7/V	3,0..5,5 lux

The suffix indicates the colour of the photocell enclosure:

/R	red
/A	blue
/V	green

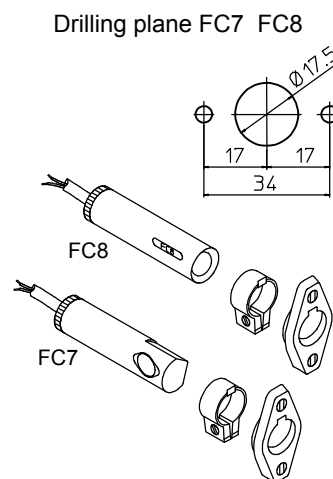

Fig.3

The figures (Fig.3) show the types and fixing systems of the available flame detectors.

To fix the flame detector screws diameter 4 are suggested.

Cable holders and core hitches can be fitted on the sides of the enclosure and the connecting sockets. These accessories can be supplied upon request (see Fig.4).

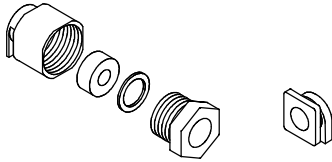

Fig.4

#### DIRECTIONS FOR USE

- Automatic controls are safety devices and must not be opened. The manufacturer's responsibility and guarantee are invalidated if the control is incautiously opened.
- For safety reasons a regulation shutdown must occur every 24 hours (systems for non permanent operation).
- The control has to be connected and disconnected only without the mains power.
- The control can be mounted in any position.
- Avoid exposing the control unit to dripping water.
- Ventilation and the lowest temperature ensure the longest life of the control.
- Make sure that the type (code and times) you are using is correct before installing or replacing the control.

#### ELECTRICAL INSTALLATION

- The applicable national and European standards (e.g. EN 60335-1/EN 50165) regarding electrical safety must be respected.
- **Phase** and **Neutral** should be connected correctly; a mistake could cause a dangerous situation, as the internal safety devices can be ineffective in case the connecting wires of thermostats and valves are not isolated.
- Before starting the control unit check the cables carefully. Wrong connections can damage the control and compromise the safety of the application.
- The **earth** terminal of the control, the metal frame of the burner and the **earth** of the electric system must be well connected.
- Avoid putting detection cables close to power or ignition cables.
- Protect the control with a fast fuse suitable to the load connected and never exceeding 4A.
- The appliance in which the control is installed must provide adequate protection against the risk of electrical shock.

#### CHECKING AT START

Always check the control before the first start and also after any replacement or a long period of non operation of the system.

Before any ignition attempt make sure that the combustion chamber is free from oil.

Then make sure that:

- if the starting attempt occurs with the flame detector obscured the control performs a lockout after safety time;
- if start up takes place with extraneous light the control performs a lockout within 10 seconds;
- when the flame detector is obscured in running position, supply to the oil valve(s) is interrupted within 1 second and after a recycling the control proceeds to lockout;
- the intervention of limiters or safety devices cause a safety shutdown according to the application;
- operating times and sequence are suitable to the control box used.

#### OPERATION

At every start the control unit supplies the burner motor and the ignition transformer and proceeds to a self-checking of its own components. During the pre-purge time TV the internal circuit makes a test of the flame signal amplifier circuit. Extraneous light or a fault in the amplifier cause the lockout of the control within 10 seconds. At the end of pre-purge time the oil valve output is supplied; if a flame signal is detected at the end of safety time, the control unit deenergizes the ignition transformer and goes to running position. If no flame signal is detected during safety time, the control goes to lockout, the control outputs of the valve, the ignition transformer and the burner motor are switched off while the lockout signal output is supplied. The controls prearranged for the use of an oil pre-heater supply the pre-heater when the room thermostat and/or the boiler one switch off. In this way the starting sequence begins. The thermostat opening causes the repetition of the starting sequence after the heating stage (RISC) of the pre-heater. The attached diagrams are useful to understand how each control operates.

#### Abnormal operation - Extraneous light

All control boxes of this series perform a lockout within 10 seconds.

#### RESET OF THE CONTROL

When a control has gone to lockout, a delay of 5 seconds should be considered before attempting to reset the control unit; if this time is not observed the control may not reset.

#### TESTING THE FLAME SIGNAL

It is extremely important to test the flame signal level before having the burner operate.

Arrange one cable connected to terminal no. 9 and no. 8 (or one cable connected to the neutral terminal). These cables should be accessible when the control is mounted on the socket; then, with the burner in running position, the voltage between terminals must be  $< 0,5V$ . This value guarantees a safe operation; it corresponds to a light intensity 50% beyond the limit value (about 0,8V). In case the tested voltage is higher, try to better orientate the photocell or to clean it (see Fig.5).

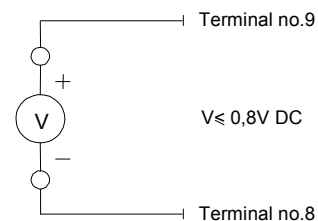
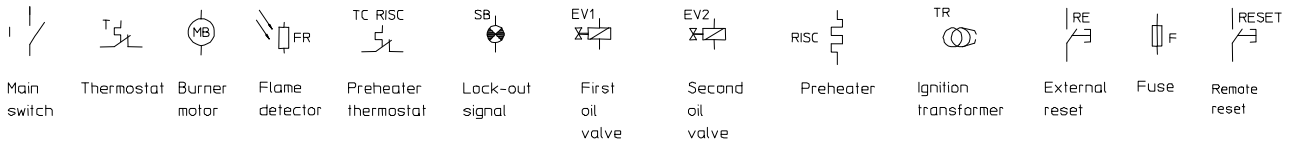
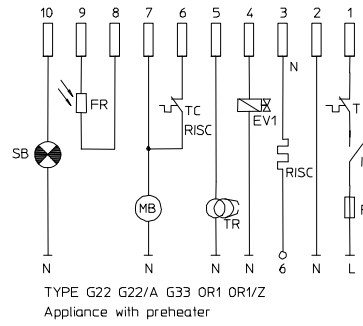
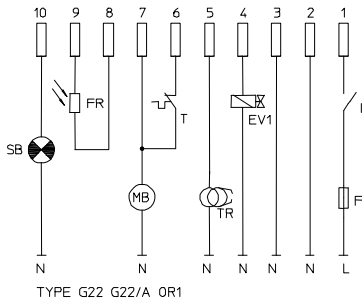
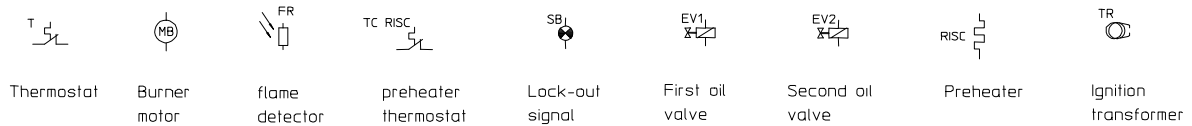
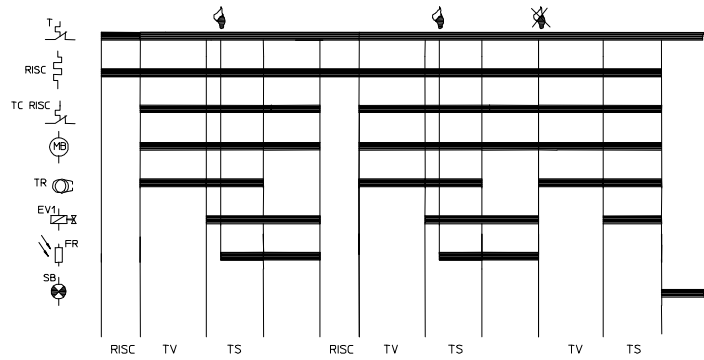
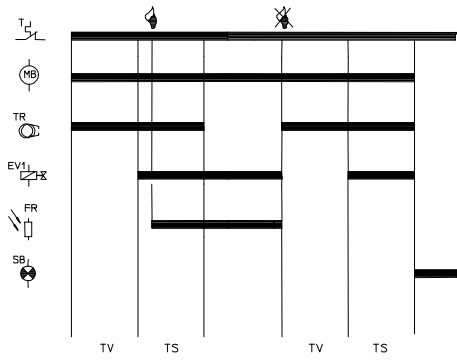

Fig.5

# CONNECTION DIAGRAMS



# OPERATING CYCLES



2004/04/28 Subject to amendments without notice