

S4565/S4575/S4585 SERIES

IGNITION CONTROLS FOR COMBINED VALVE AND IGNITION SYSTEM

INSTRUCTION SHEET

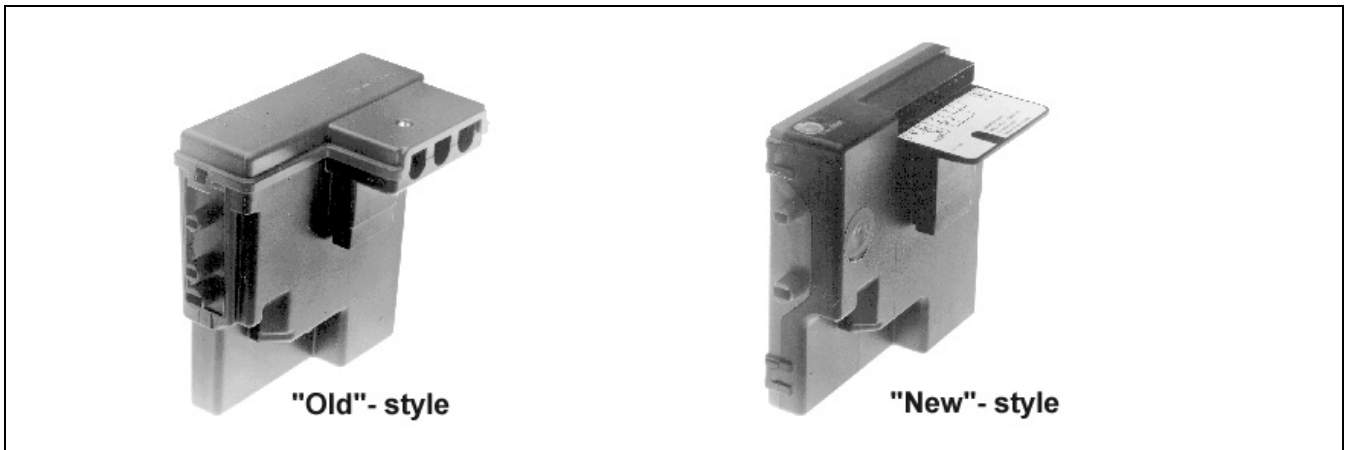

APPLICATION

The Combined Valve and Ignition system (CVI) has specially been developed for application in gas fired appliances with either intermittent pilot or direct burner ignition.

For this system, the VK41../VK81.. series gas controls have been designed to have the S4565/S4575/S4585 series ignition controls attached directly onto the valve.

The combined system then provides programmed safe light up, flame supervision and regulation of gas flow to the main burner and/or pilot burner of the appliance.

DESCRIPTION

The S4565/S4575 ignition controls provide automatic ignition for direct gas burner applications and for intermittent pilot gas burner applications with safety timer.

The S4565/S4575 ignition controls are not intended for direct exposure to flame envelope.

The S4585 ignition controls provide automatic ignition for intermittent pilot gas burner applications without safety timer.

The S4565/S4575/S4585 ignition controls are designed to meet the european standards:

EN 298: Automatic gas burner control systems.

EN 60730-1:Automatic electrical controls for house hold and similar use.

The S4565/S4575/S4585 ignition controls can be used in appliances according European standard for household electrical requirements EN 60335 series.

The S4565/S4575 ignition controls are approved on the North American standard ANS Z21.20 Automatic Ignition Systems.

NOTE: S4565SD is not an ignition control but an ignition circuit and rectifier only

Contents

Page	Contents
Dimensional drawing	2
Features	3
S4565A, B, P, Q	3
S4565C, D, R, T	4
S4565AD, BD, CD, DD, PD, QD, RD, TD "1000-series"	7
S4565AD, BD, CD, DD, PD, QD, RD, SD, TD "2000" series	13
S4565AF, BF, CF, DF, PF, QF, RF, TF	19
S4565PV, QV, RV, TV	25
S4575A, B, P, Q	32
S4585D	34
General considerations	36
Electrical connections	37

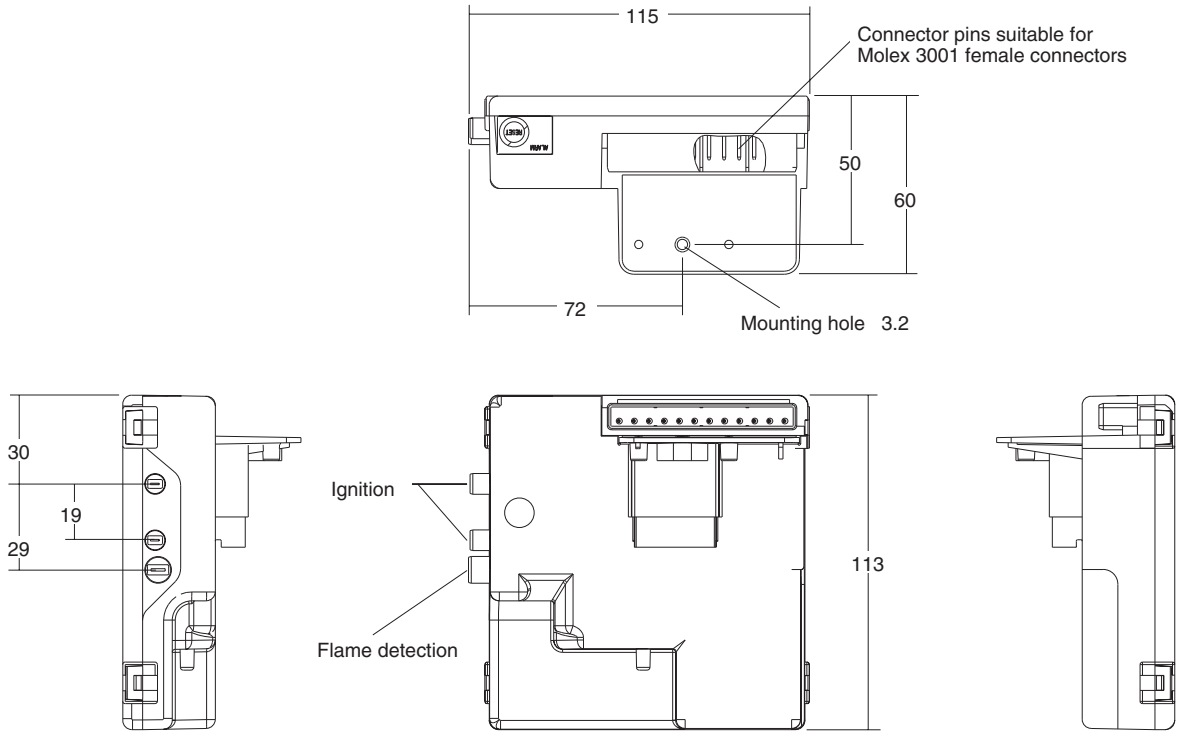

Note: specific housings may deviate from drawing

Fig. 1. Dimensional drawing “new style” housing in mm

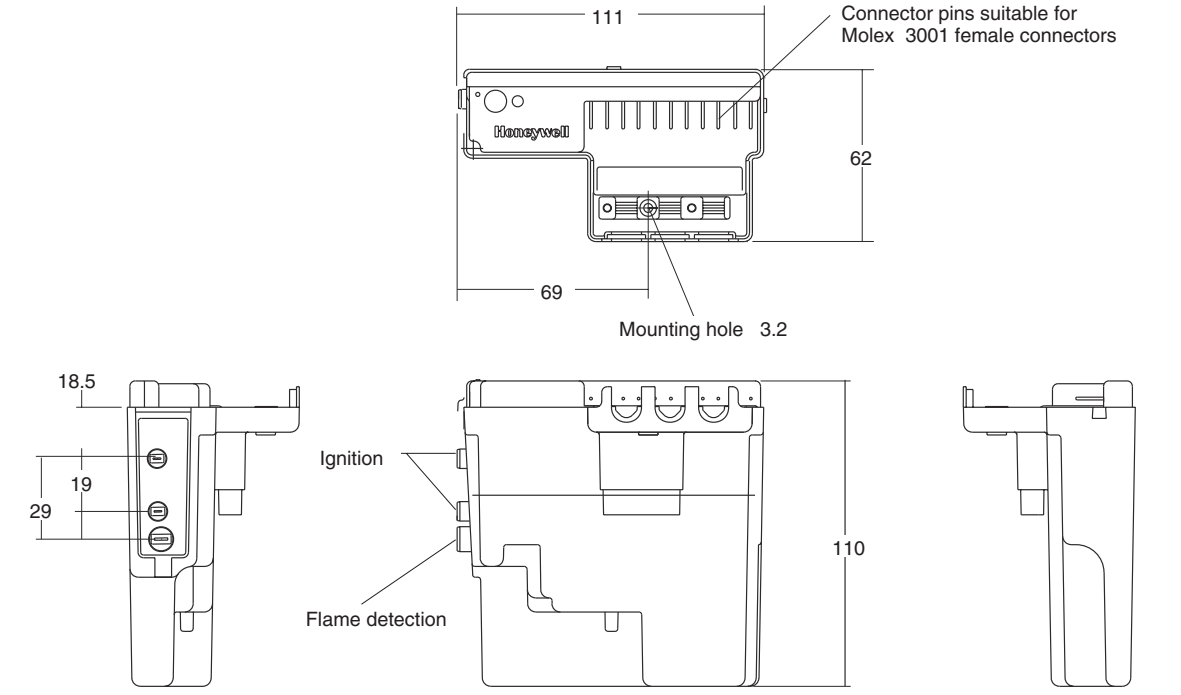

Note: specific housings may deviate from drawing

Fig. 2. Dimensional drawing “old style” housing in mm

FEATURES IGNITION CONTROLS

- Flame supervision.
- Built-in 2.5 ... 60 Hz ignition.
- Internal or external reset and alarm.
- Accurate safety timer.
- Supply voltages of 220 ... 240 V in a single product.
- Full operating sequence after flame loss.
- Extended spark time.
- Optional phase neutral independent operation, flame sensing independent of safety ground potential for S4565AD ... TD "2000" series and S4575.

- Safety time triggered by Air Pressure Switch (APS) for S4565AD ... TD "2000" series and S4575.
- Optional safe separation flame relay output or opto coupler.
- Optional main burner interrupt for S4565 BF, DF, QF, TF.
- Volatile or non volatile lock-out according EN 298.
- EMC filter optional
- Protective impedance flame rod
- Under voltage protection

SPECIFICATIONS DIRECT BURNER IGNITION CONTROL S4565A, B, P, Q

Model

Suffix A: atmospheric, direct burner ignition
 Suffix B: atmospheric, direct burner ignition, flame relay output

Suffix P: as A except volatile lock-out
 Suffix Q: as B except volatile lock-out

Supply voltage

220 ... 240 Vac, 50/60 Hz

Power consumption

4 VA

Humidity

90% RH max. at 40 °C

Ambient temperature

-15 ... 60 °C

Electrical rating (see also note 2, page 4)

Alarm: 220 ... 240 Vac, 50/60 Hz, 1 A, $\cos \varphi > 0.6$ or 1 mA max.

Flame relay contact: 220 ... 240 Vac, 50/60 Hz, 1 A, $\cos \varphi > 0.6$

Flame opto coupler: +5 V, 10 k Ω

Electrical connection

High voltage spark: 2.8 mm spade terminal

Flame sensing: 4.8 mm spade terminal

PCB connectors: Molex 3003 series suitable for Molex 3001 female cable connector

Housing (degree of protection)

See page 38

Timing (depending on O.S. number)

Self check time (T_c): 1.5 s

Waiting time (T_w): 0 ... 30 s

Safety time (T_s): 3.5 ... 55 s

Extended spark ignition time: 0 ... T_s

Flame sensing

Min flame current: 0.9 μ A

Response time on: > 0.2 s

Response time off (T_{FR}): < 1 s (optionally other values available)

Ignition

Spark voltage: > 12 kV at 40 pF load

Spark energy: 3 ... 15 μ As

Repetition rate: 2.5 ... 60 Hz (depending on O.S. number)

Max. spark gap: 3.5 mm

Length flame sensing cable

1 m max.

Length ignition cable

0.5 m max.

Length of wiring for external components

1 m max.

Remark

Optional integrated flame relay available with safe separation or opto coupler with safe separation.

N.C. contact of flame relay has no safe separation.



WARNING

Opto coupler interface needs a debounce time > 20 ms in order to prevent noise caused by transients on mains.

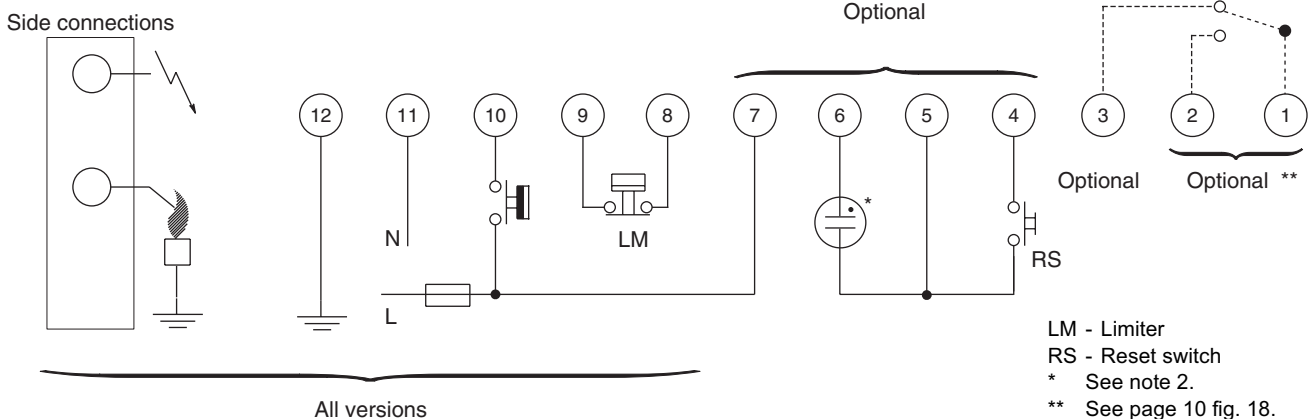

Fig. 3. Connection diagram S4565A, B, P, Q

SYSTEM OPERATION

General

Lock-out reset

The S4565 ignition control can be reset by either depressing the internal/external reset button (suffix A and B) or by interrupting the permanent life (suffix P and Q).

NOTE 1.: If during normal use the reset button is pressed, the gas valves drop out and the S4565 ignition control starts a new sequence after releasing the reset button.

NOTE 2.: If permanent alarm output:neon indicator with integral resistor >150 kΩ (max 1 mA)

NOTE 3.: If an return high limit thermostat is used, the high limit switch in the application needs a longer return time than the trial for ignition time of the control. This in order to provide non volatile lock-out.

Suffix A, B, P and Q (see fig. 4.)

When there is a call for heat a self check period (T_c) plus waiting period (T_w) elapse before built-in igniter and gas valve are switched on.

The ignition spark ignites gas and resulting flame is detected by the flame rod.

Ignition is switched off after extended ignition time and flame establishment.

If flame is not established within the safety time (T_s), the S4565 ignition control locks-out.

If the flame is lost during normal run, the S4565 ignition control repeats start sequence.

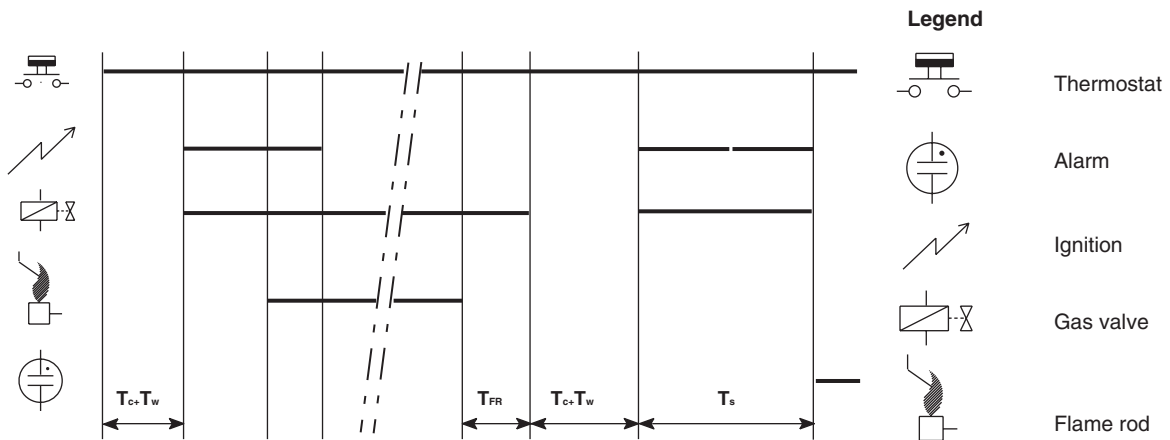

Fig. 4. Timing diagram S4565A, B, P, Q

SPECIFICATIONS IGNITION CONTROL S4565C, D, R, T

Model

- Suffix C: fan assisted, direct burner ignition
- Suffix D: fan assisted, intermittent pilot burner ignition including safety timer
- Suffix R: as C except volatile lock-out
- Suffix T: as D except volatile lock-out

Supply voltage

220 ... 240 Vac, 50/60 Hz

Power consumption

4 VA

Humidity

90% RH max. at 40 °C

Ambient temperature

-15 ... 60 °C

Electrical rating (see also note 5. page 6)

- Alarm: 220 ... 240 Vac, 50/60 Hz, 1 A, $\cos \phi \geq 0.6$ or max 1 mA
- Fan: 220 ... 240 Vac, 50/60 Hz, 1 A, $\cos \phi \geq 0.6$
- LPG outdoor valve: 220 ... 240 Vac, 50/60 Hz, 1 A, $\cos \phi \geq 0.6$
- External ignition transformer: 220 ... 240 Vac, 50/60 Hz, 1 A, $\cos \phi \geq 0.6$

Electrical connection

- High voltage spark: 2.8 mm spade terminal
- Optional: External mains voltage ignition transformer with 2.8 mm spade terminal
- Flame sensing: 4.8 mm spade terminal or 2.8 mm spade terminal for combined high voltage spark/ flame sensing
- PCB connectors: Molex 3003 series suitable for Molex 3001 female cable connector

Housing (degree of protection)

See page 38

Timing (depending on O.S. number)

- Self check time (T_c): 0, 1.5 or 2 s
- Prepurge time (T_p): 0 ... 30 s
- Safety time (T_s): 3.5 ... 55 s
- Extended spark ignition time and stabilisation time: 0 ... T_s (dependent on elaps of safety time)

Flame sensing

- Min flame current: 0.9 μ A
- Response time on: > 0.2 s
- Response time off (T_{FR}): < 1 s optionally other values available

Ignition

Spark voltage: >12 kV at 40 pF load
 Spark energy: 3 ... 15 μAs
 Repetition rate: 2.5 ... 60 Hz (depending on O.S. number)
 Max spark gap: 3.5 mm

Length flame sensing cable

1 m max.

Length ignition cable

0.5 m max.

Length of wiring for external components

1 m max.

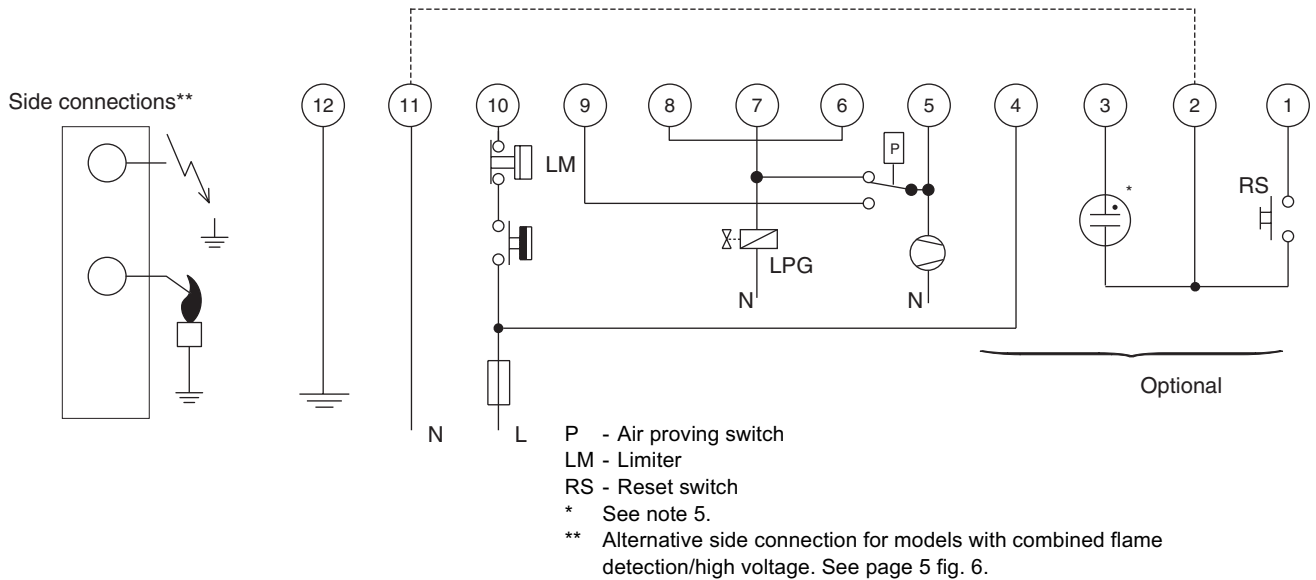

Fig. 5. Connection diagram S4565C, D, R, T

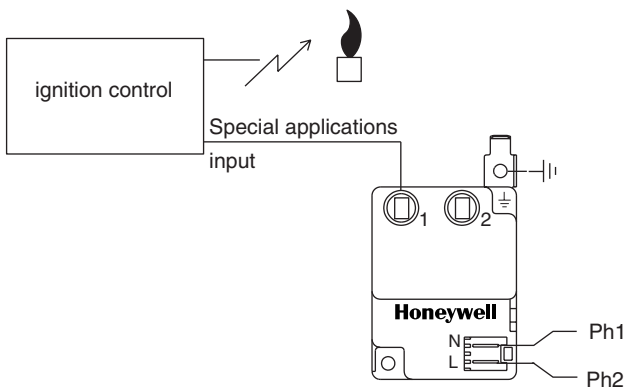

Fig. 6. Alternative side connection for models with combined flamedetection/high voltage.

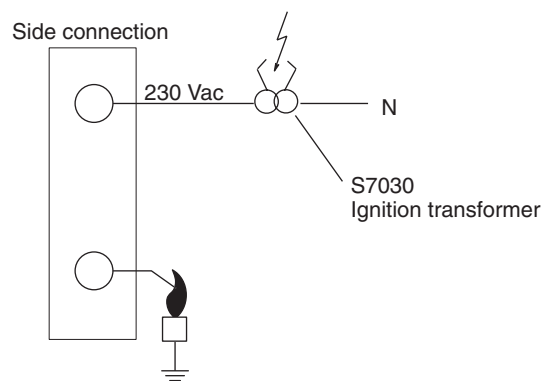

Fig. 7. Alternative side connection for models with flame sense input + 230 Vac output for external ignition transformer

SYSTEM OPERATION

General

Lock-out reset

The S4565 can be reset by either depressing the internal/external reset button (suffix C and D) or by interrupting the permanent life (suffix R and T).

NOTE 4.: If during normal use the reset button is pressed, the gas valves close and the S4565 ignition control starts a new sequence after releasing the reset button.

NOTE 5.: If permanent alarm output:neon indicator with integral resistor >150 kΩ (max 1 mA)

Suffix C and R (see fig. 8.)

When there is a call for heat the fan starts running through the no air position of the air proving switch. If an external LPG valve is connected, this will be energized. When sufficient air flow is proven by the air proving switch, a self check period (T_c) and prepurge period (T_p) elapse before the gas valve and built-in ignition or external ignition transformer (optional) are switched on. The ignition spark ignites gas and resulting flame is detected by the flame rod. Internal or external ignition is switched off. After flame establishment a predetermined, extended ignition time can be included. If flame is not established within the safety time (T_s), the S4565 ignition control locks out.

If the flame is lost during normal run, the S4565 ignition control repeats the start sequence with prepurge. If no air is proven by the air proving switch within the prepurge time (T_p), the ignition control stays in waiting mode with fan running.

Suffix D and T (see fig. 9.)

When there is a call for heat the fan starts running through the no air position of the air proving switch. If an external LPG valve is connected, this will be energized. When sufficient air flow is proven by the air proving switch, a self check period (T_c) and prepurge period (T_p) elapses before the pilot gas valve and built-in ignition or external ignition transformer (optional) are switched on. The ignition spark ignites pilot gas and resulting flame is detected by the flame rod. Internal or external ignition is switched off. After flame establishment a predetermined, extended ignition time can be included and flame establishment and the main valve is switched on. If flame is not established within the safety time (T_s), the S4565 ignition control locks out. If the flame is lost during normal run, the S4565 ignition control repeats start sequence at prepurge. If no air is proven by the air proving switch within the prepurge time (T_p), the ignition control stays in waiting mode with fan running.

WARNING

Do not interchange air proving switch wiring in order to prevent malfunctioning

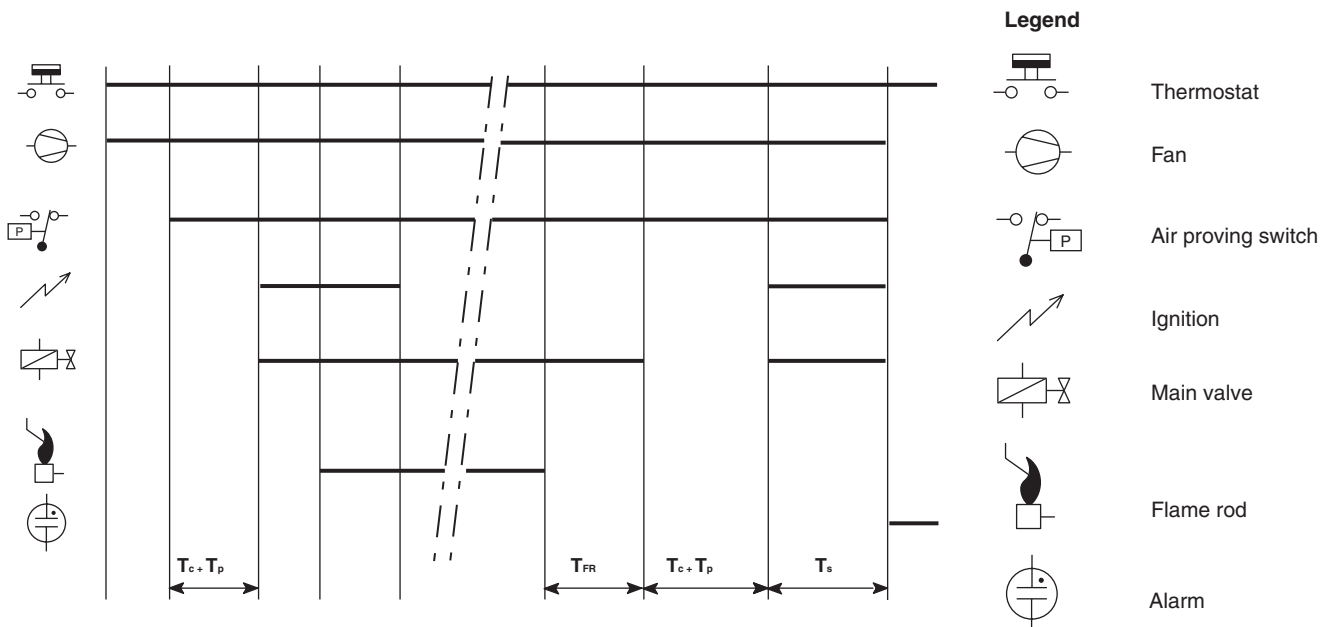

Fig. 8. Timing diagram S4565C, R

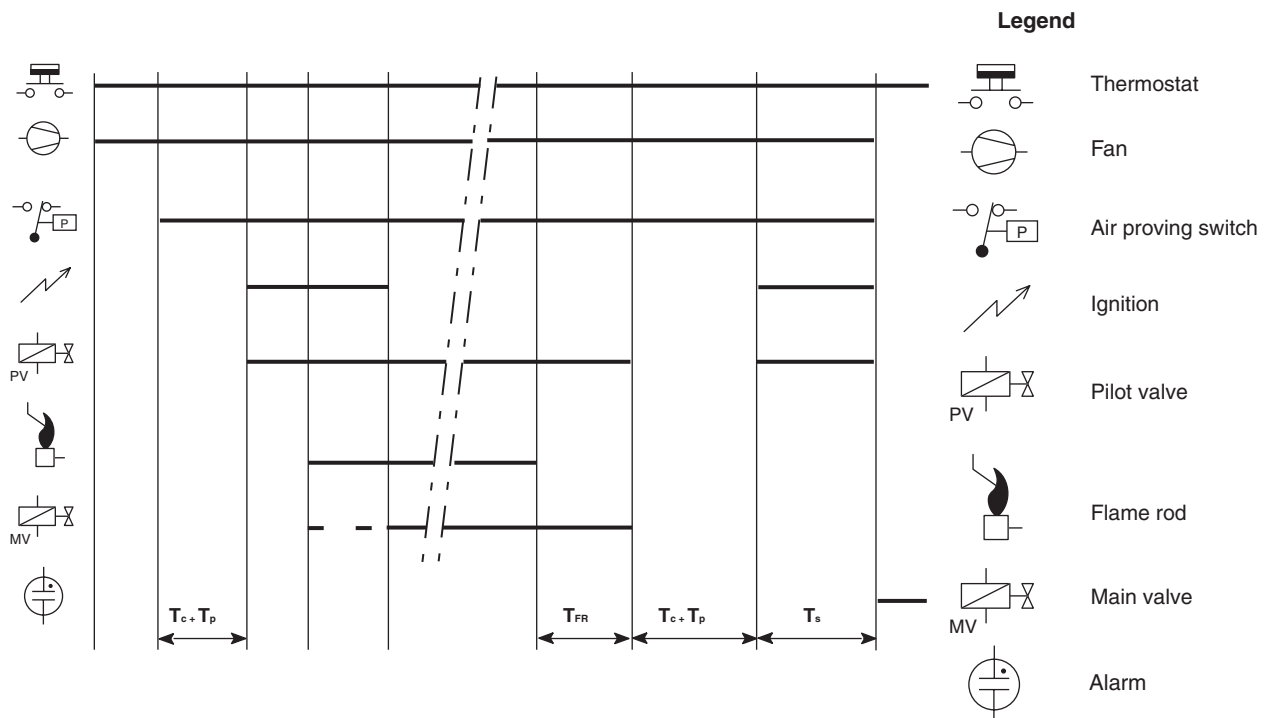

Fig. 9. Timing diagram S4565D, T

SPECIFICATIONS DIRECT BURNER IGNITION CONTROL S4565AD, BD, CD, DD, PD, QD, RD, TD “1000-SERIES”

Model

Suffix AD: atmospheric, direct burner ignition
 Suffix BD: as AD but with flame relay output
 Suffix CD: fan assisted, direct burner ignition
 Suffix DD: as CD but with flame relay output
 Suffix PD: as AD except volatile lock-out
 Suffix QD: as BD except volatile lock-out
 Suffix RD: as CD except volatile lock-out
 Suffix TD: as DD except volatile lock-out

Supply voltage

220 ... 240 Vac, 50/60 Hz

Power consumption

4 VA

Humidity

90% RH max. at 40 °C non condensing

Ambient temperature

-15 ... 60 °C

Electrical rating (see also note 8. page 11)

Alarm: 220 ... 240 Vac, 50/60 Hz, 1 A,
 $\cos \varphi > 0.6$ or max 1mA

Fan: 220 ... 240 Vac, 50/60 Hz, 1 A,
 $\cos \varphi > 0.6$

Flame relay contact: 220 ... 240 Vac, 50/60 Hz, 1 A,
 $\cos \varphi > 0.6$

Flame opto coupler: +5 V, 10 k Ω

LPG valve: 220 ... 240 Vac, 50/60 Hz, 1 A max, $\cos \varphi > 0.6$

Electrical connection

High voltage spark: 2.8 x 0.5 mm spade terminal
 Flame sensing: 4.8 x 0.8 mm spade terminal
 PCB connectors: Molex 3003 series suitable for Molex 3001 female cable connector

Housing (degree of protection)

See page 38

Timing (depending on O.S. number)

Self check time (T_c): 1.5 s
 Waiting time (T_w): 0 ... 30 s
 Safety time (T_s): 3.5 ... 25 s
 Extended spark ignition time: 0 ... T_s (dependent on elaps of safety time)

Flame sensing

Min flame current: 0.9 μ A
 Response time on: > 0.2 s
 Response time off (T_{FR}): < 1 s

Ignition

Spark voltage: >12 kV at 40 pF load
 (depending on O.S. number)
 Spark energy: 3 ... 15 μ As
 Repetition rate: 2.5 ... 60 Hz (depending on O.S. number)
 Max. spark gap: 3.5 mm
 Optional external ignition circuit: 220 ... 240 V (at no load), single phase rectified, max 2 VA

Length flame sensing cable
1 m max.

Length ignition cable
0.5 m max.

Length of wiring for external components
1 m max.

Remark

Optional integrated flame relay available with safe separation or opto coupler with safe separation.

N.C. contact of flame relay has no safe separation.

! WARNING

Opto coupler interface needs a debounce time > 20 ms in order to prevent noise caused by transients on mains.

Side connections **

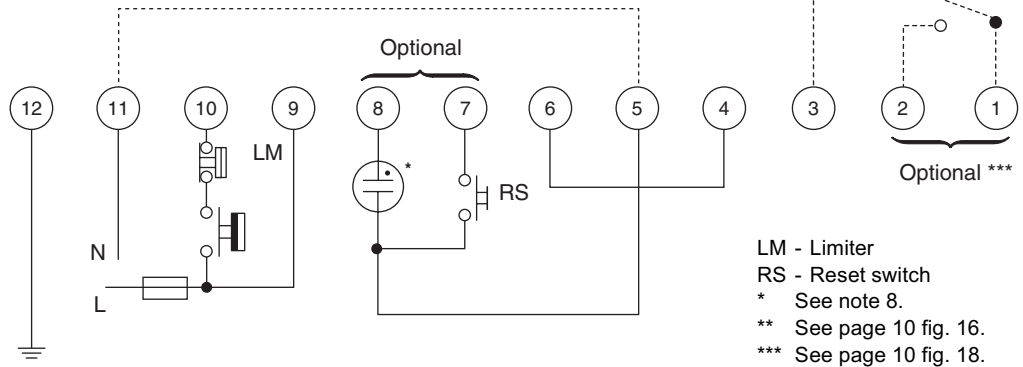
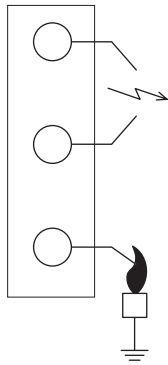

Fig. 10. Connection diagram S4565AD and BD "1000" series

Side connections **

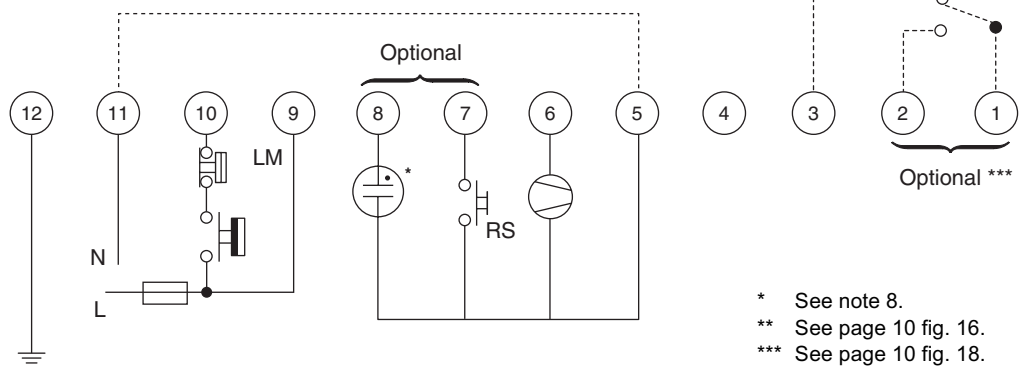
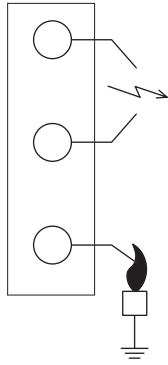

Fig. 11. Connection diagram S4565BD and QD "1000" series for gas/air application

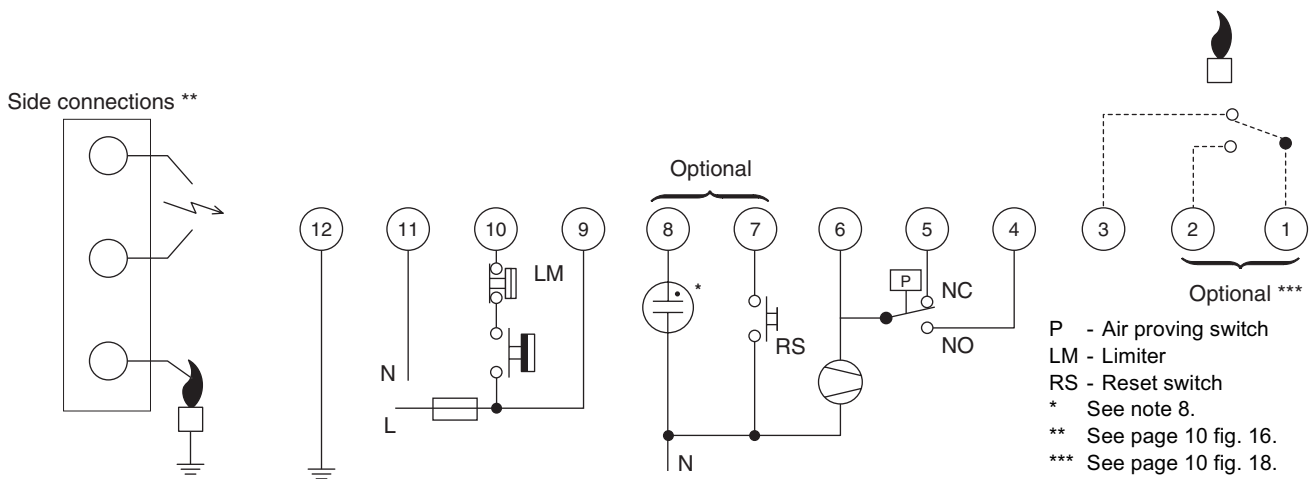

Fig. 12. Connection diagram S4565CD and DD "1000" series

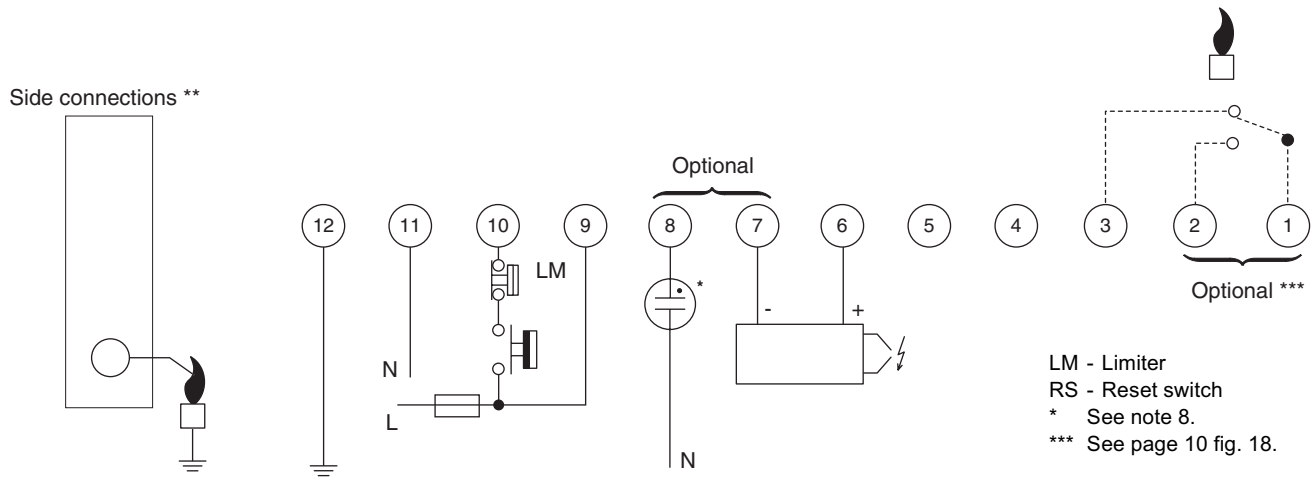

Fig. 13. Connection diagram S4565QD "1000" series with external ignition circuit

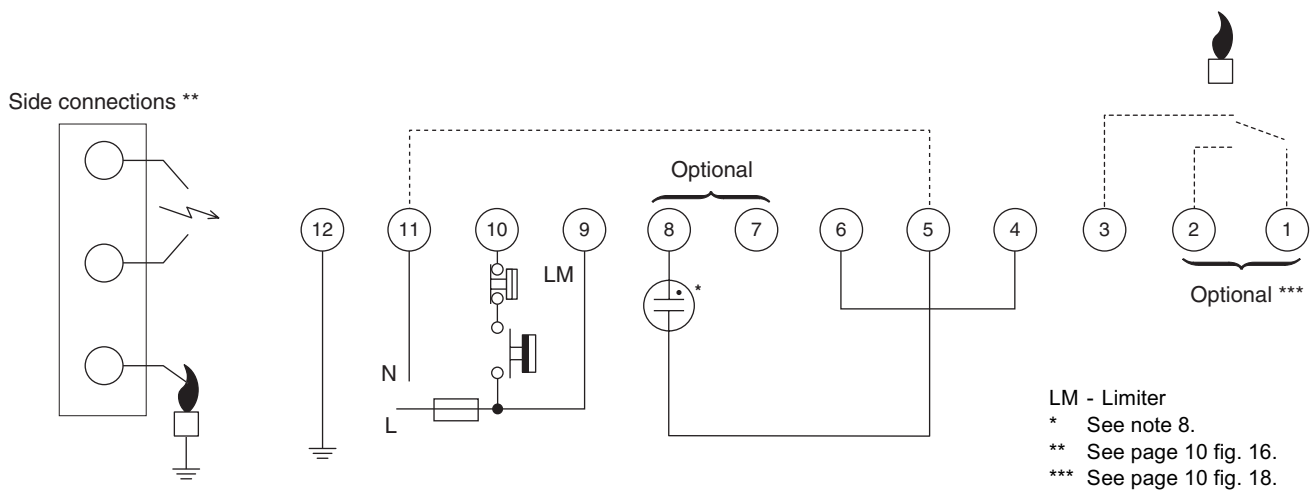

Fig. 14. Connection diagram S4565PD and QD "1000" series

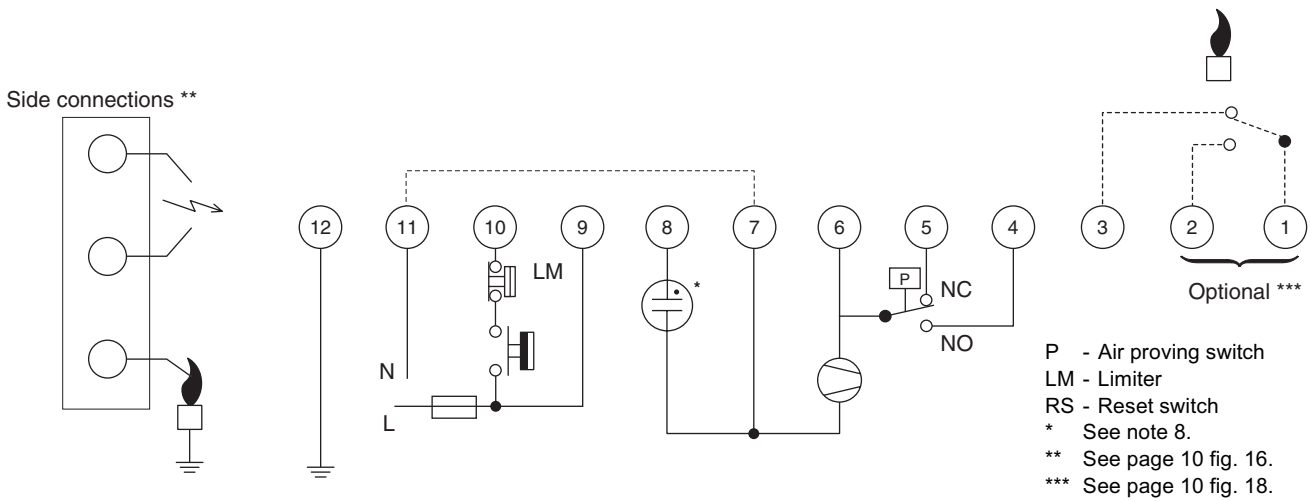

Fig. 15. Connection diagram S4565RD and TD "1000" series

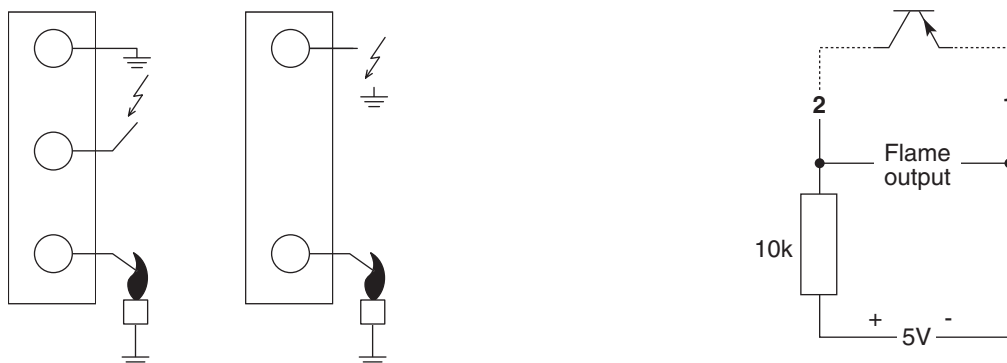

Fig. 16. Alternative side connection in case of sparking to ground

Fig. 18. Connection for opto coupler output

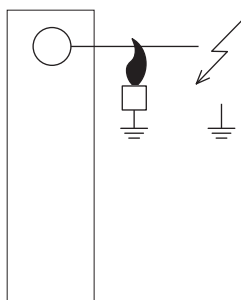

Fig. 17. Alternative side connection in case of combined flame sensing and sparking (single rod)

SYSTEM OPERATION

General

The S4565AD, BD, CD, DD, PD, QD, RD, TD ignition control can provide both closed-loop sparking and sparking to ground.

If the S4565AD, BD, CD, DD, PD, QD, RD, TD will be used in sparking to ground applications, the upper spark tab has to be grounded.

Lock-out reset

The S4565 can be reset by either depressing the internal/external reset button (suffix AD, BD, CD and DD) or by interrupting the permanent life (suffix PD, QD, RD and TD).

NOTE 6.: When first starting, the ignition control can be in the lock-out condition; reset the ignition control.

After a reset an extended waiting time will occur.

NOTE 7.: If during normal use the reset button is pressed, the gas valves close and the S4565 ignition control starts a new sequence after releasing the reset button.

NOTE 8.: If permanent alarm output: neon indicator with integral resistor >150 kΩ (max 1 mA)

Suffix AD and PD (see fig. 19.)

When there is a call for heat a self check period (T_c) plus waiting period (T_w) elapses before the built-in igniter and gas valve are switched on.

The ignition spark ignites gas and resulting flame is detected by the flame rod.

After flame establishment a predetermined, extended ignition time can be included.

If flame is not established within the safety time (T_s), the S4565 ignition control locks-out.

If the flame is lost during normal run, the S4565 ignition control repeats start sequence.

Suffix BD and QD (see fig. 20.)

As AD and PD except flame relay contact or opto is closed after flame detection.

Suffix CD and RD (see fig. 21.)

When there is a call for heat the fan starts running through

the no air position of the air proving switch after a self check period (T_c) plus waiting period (T_w). When sufficient air flow is proven by the air proving switch, the built-in igniter and gas valve are switched on.

The ignition spark ignites gas and resulting flame is detected by the flame rod.

After flame establishment a predetermined, extended ignition time can be included.

If flame is not established within the safety time (T_s), the S4565 ignition control locks out.

If the flame is lost during normal run, the S4565 ignition control repeats start sequence.

If no air is proven by the air proving switch within the safety time (T_s), the ignition control locks-out.

Suffix DD and TD (see fig. 22.)

As CD and RD except flame relay contact or opto is closed after flame detection.

Gas/air application

For gas/air application without dynamic aircheck, the S4565AD, BD, PD or QD can be used.

In this application the fan is connected between pin 4 and 5 and will start when a call for heat is present. The waiting period now acts as a prepurge time.

When the call for heat disappears or when the ignition control goes in lock-out, the fan will be switched off.

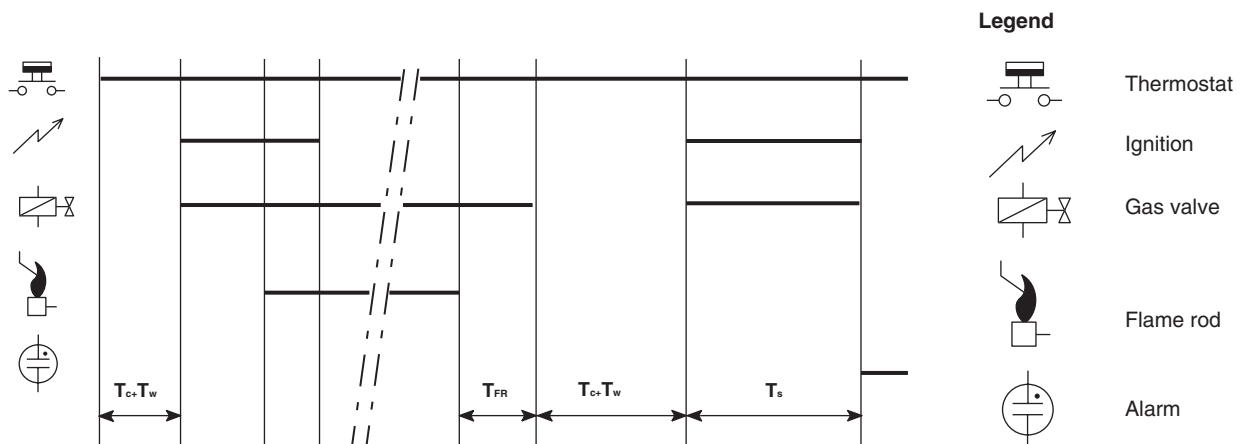

Fig. 19. Timing diagram S4565AD, PD "1000" series

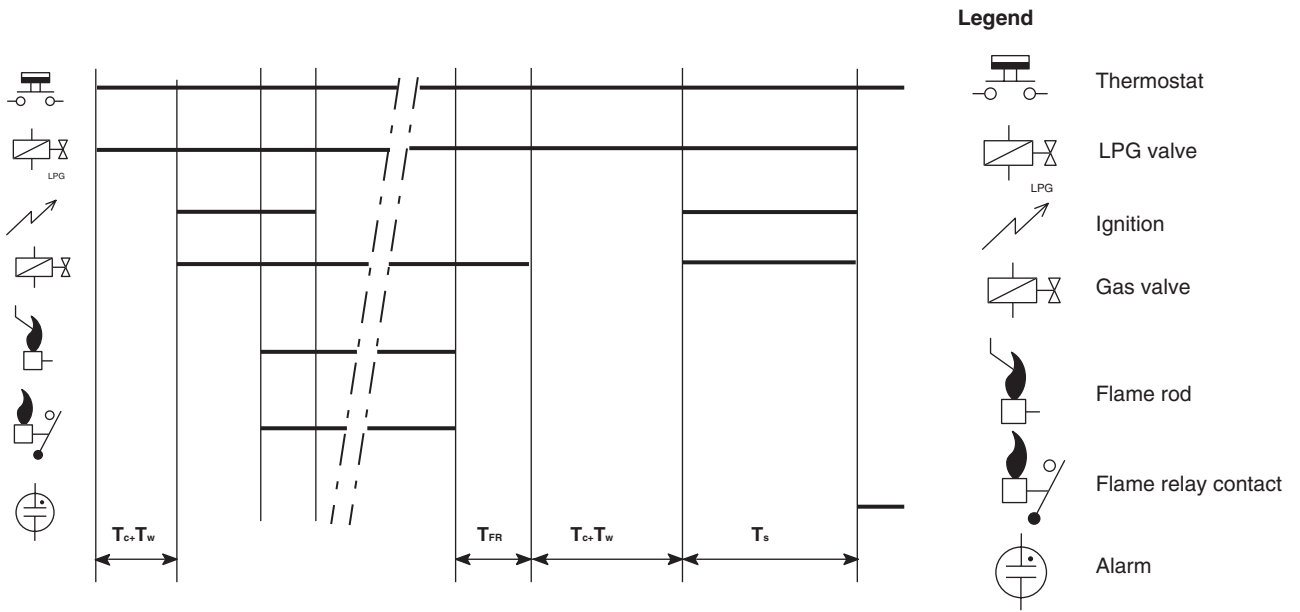

Fig. 20. Timing diagram S4565BD, QD "1000" series

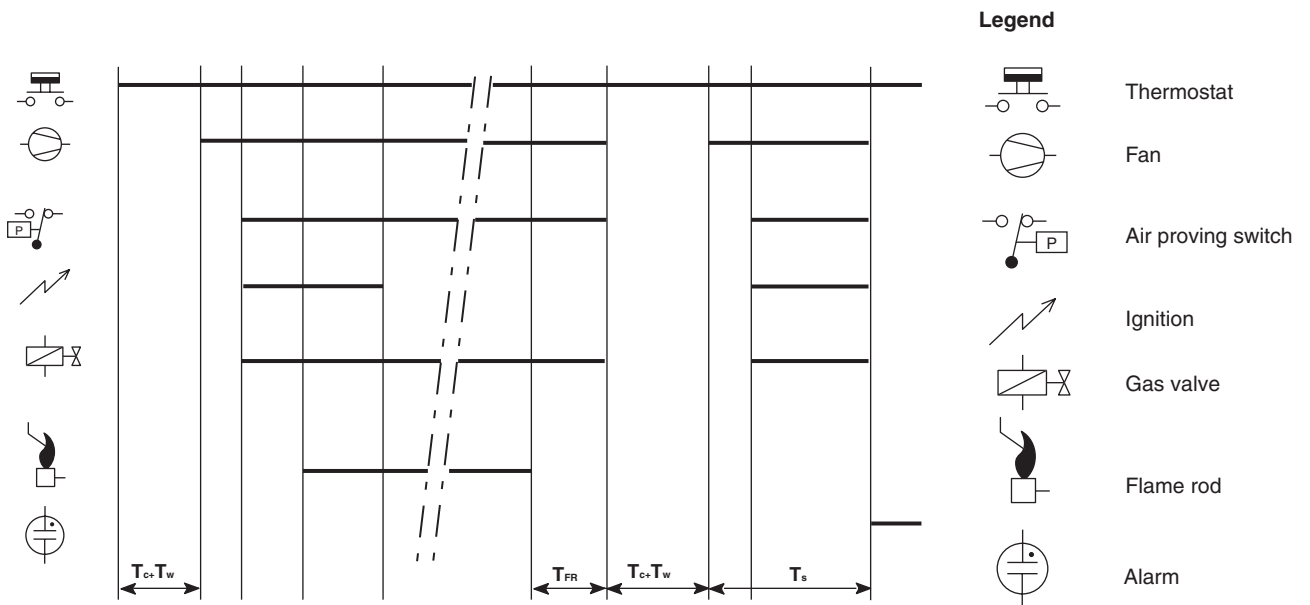

Fig. 21. Timing diagram S4565CD, RD "1000" series

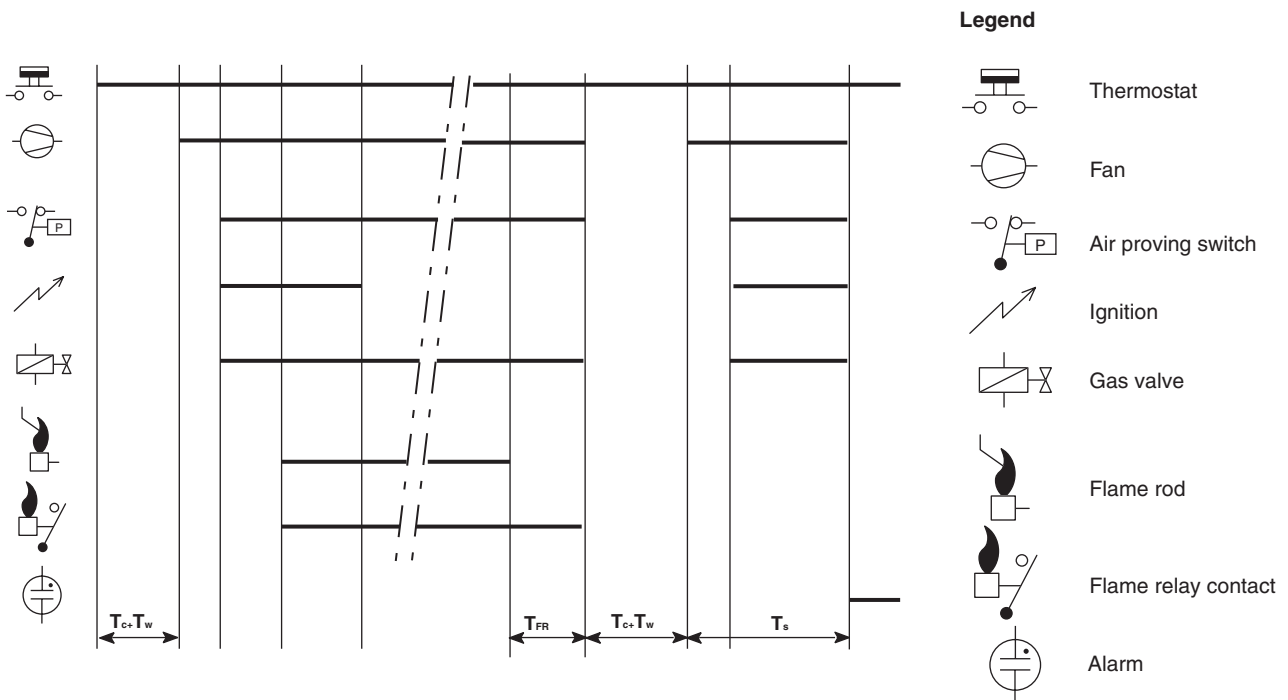

Fig. 22. Timing diagram S4565DD, TD "1000" series

SPECIFICATIONS DIRECT BURNER IGNITION CONTROL S4565AD, BD, CD, DD, PD, QD, RD, SD, TD "2000" SERIES

Model

Suffix AD: atmospheric, direct burner ignition
 Suffix BD: as AD but with flame relay output
 Suffix CD: fan assisted, direct burner ignition
 Suffix DD: as CD but with flame relay output
 Suffix PD: as AD except volatile lock-out
 Suffix QD: as BD except volatile lock-out
 Suffix RD: as CD except volatile lock-out
 Suffix SD: ignition circuit and rectifier only
 Suffix TD: as DD except volatile lock-out

Supply voltage

230 ... 240 Vac, 50/60 Hz

Power consumption

4 VA

Humidity

90% RH max. at 40 °C

Ambient temperature

-15 ... 60 °C

Electrical rating (see also note 8. page 11)

Alarm: 230 ... 240 Vac, 50/60 Hz, output max 1mA (e.g. neon light with internal resistor > 150 kΩ)
 Fan: 230 ... 240 Vac, 50/60 Hz, max 1 A, max $\cos \varphi > 0.6$
 Hour counter: 230 ... 240 Vac, 50/60 Hz, max 1 A, $\cos \varphi > 0.6$
 Flame relay contact: 230 ... 240 Vac, 50/60 Hz, max 1 A, $\cos \varphi > 0.6$
 Flame opto coupler: +5 V, 10 kΩ

Electrical connection

High voltage spark: 2.8 mm spade terminal
 optional: 4 mm round terminal in spark to ground application
 Flame sensing: 4.8 mm spade terminal
 PCB connectors: Molex 3003 series suitable for Molex 3001 female cable connector

Housing (degree of protection)

See page 38

Timing (depending on O.S. number)

Self check time (T_c): 0 ... 2 s
 Waiting time (T_w): 0 ... 30 s
 Safety time (T_s): 3.5 ... 55 s
 Extended spark ignition time: 0 ... T_s
 (dependent on elaps of safety time)

Flame sensing

Min flame current:
 for optional phase independent systems: 0.5 μ A
 for phase dependent systems: 0.9 μ A
 Response time on: > 0.2 s
 Response time off (T_{FR}): < 1 s
 (optionally other values available)

Ignition

Spark voltage: > 12 kV at 40 pF load
 Spark energy: 3 ... 15 μAs
 Repetition rate: 2.5 ... 60 Hz (depending on O.S. number)
 Max. spark gap: 3.5 mm

Length flame sensing cable
 1 m max.

Length ignition cable
 0.5 m max.

Length of wiring for external components
 1 m max.

Remark

Optional integrated flame relay available with safe separation or opto coupler with safe separation.
 N.C. contact of flame relay has no safe separation.

! WARNING

Opto coupler interface needs a debounce time > 20 ms in order to prevent noise caused by transients on mains.

Side connections *

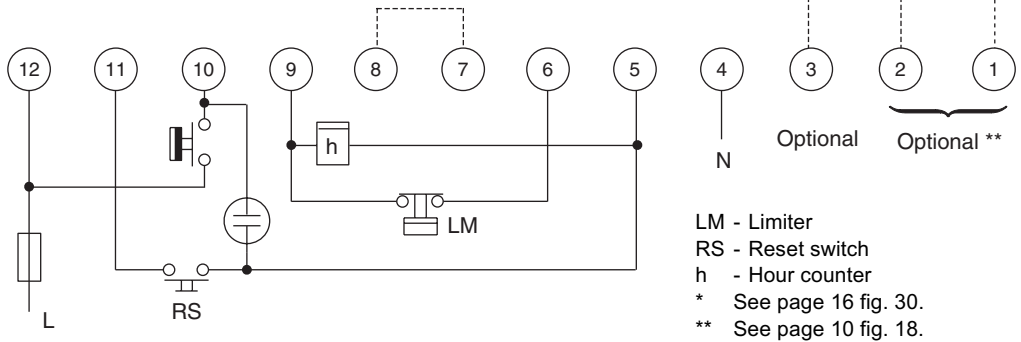
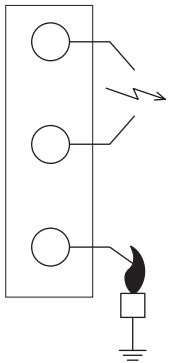

LM - Limiter
 RS - Reset switch
 h - Hour counter
 * See page 16 fig. 30.
 ** See page 10 fig. 18.

h and RS and alarm are optional

Fig. 23. Connection diagram S4565AD and BD "2000 "series

Side connections *

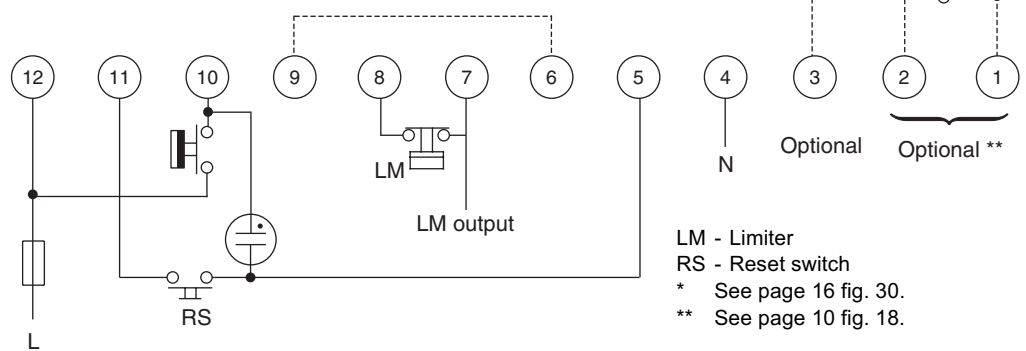
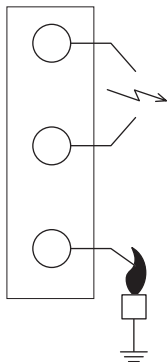

LM - Limiter
 RS - Reset switch
 * See page 16 fig. 30.
 ** See page 10 fig. 18.

h and RS and alarm are optional

Fig. 24. Connection diagram S4565AD and BD "2000 "series (optional)

Side connections *

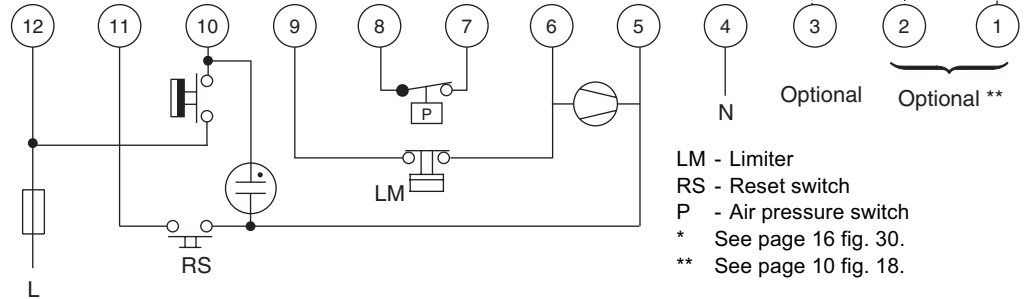
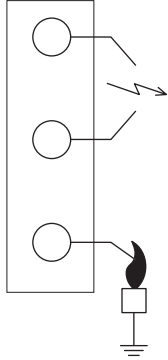

LM - Limiter
 RS - Reset switch
 P - Air pressure switch
 * See page 16 fig. 30.
 ** See page 10 fig. 18.

h and RS and alarm are optional

Fig. 25. Connection diagram S4565CD and DD "2000" series

Side connections *

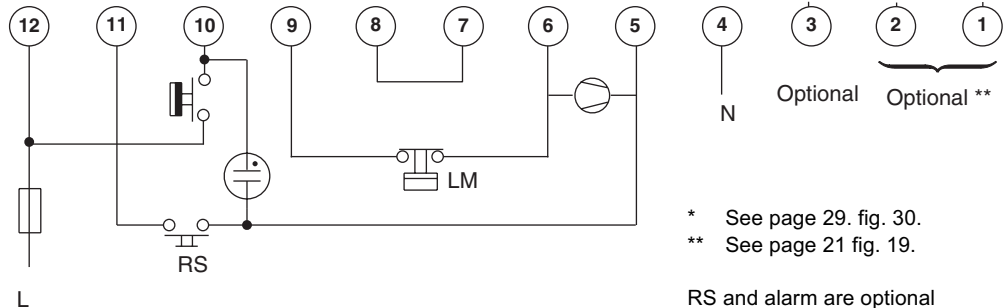
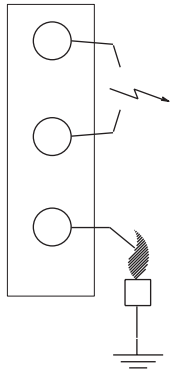

* See page 29. fig. 30.
 ** See page 21 fig. 19.

RS and alarm are optional

Fig. 26. Connection diagram S4565CD and DD "2000" series in atmospheric appliances

de connections*

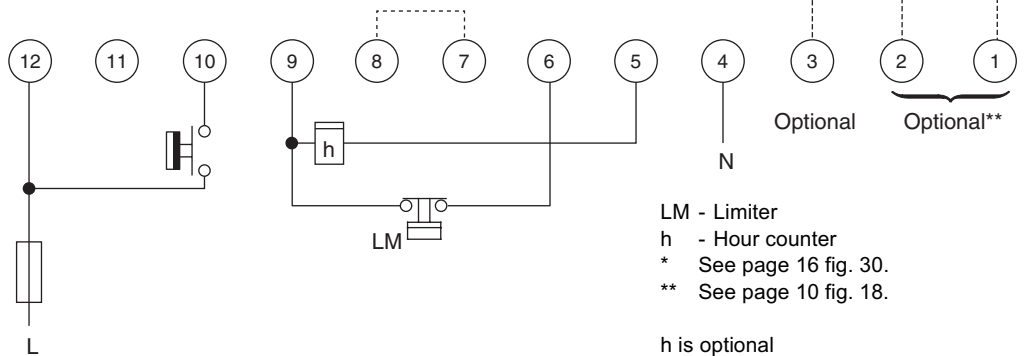
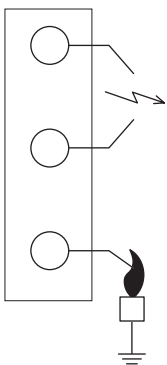

LM - Limiter
 h - Hour counter
 * See page 16 fig. 30.
 ** See page 10 fig. 18.

h is optional

Fig. 27. Connection diagram S4565PD and QD "2000" series

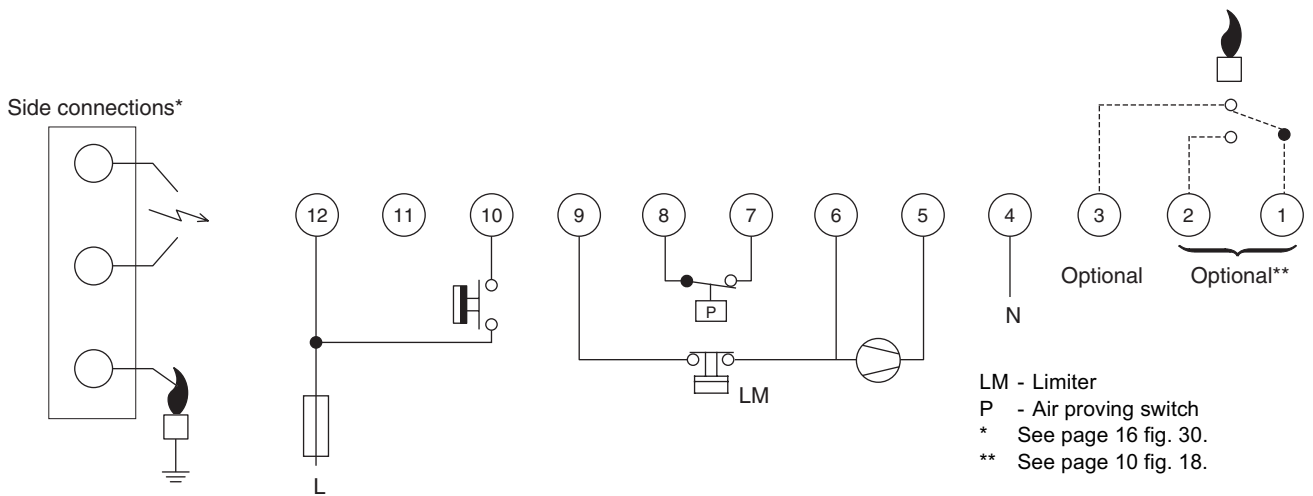

Fig. 28. Connection diagram S4565RD and TD "2000" series

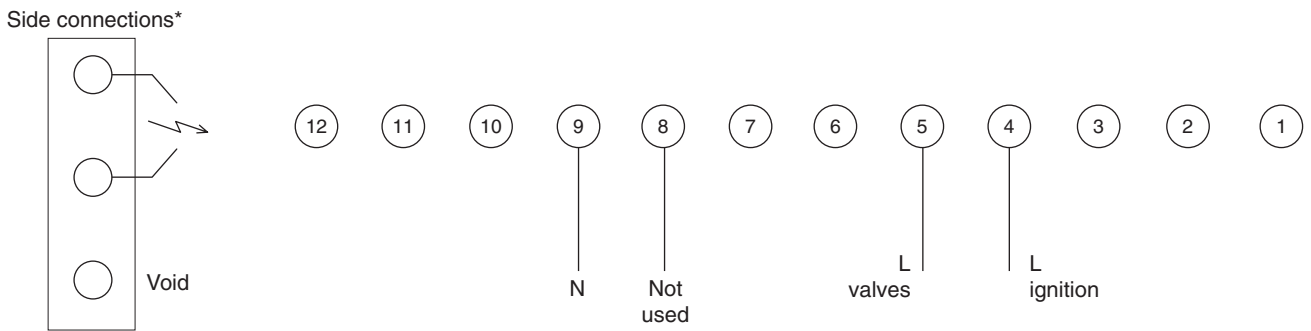

Fig. 29. Connection diagram S4565SD "2000" series

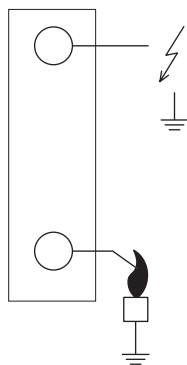

Fig. 30. Alternative side connection in case of sparking to ground

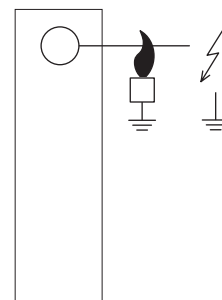

Fig. 31. Alternative side connection in case of single rod

SYSTEM OPERATION

General

The S4565AD, BD, CD, DD, PD, QD, RD, TD ignition control can provide both closed-loop sparking and sparking to ground.

The S4565SD ignition circuit and rectifier provides closed-loop sparking.

Lock-out reset

The S4565 can be reset by either depressing the internal/external reset button (suffix AD, BD, CD and DD) or by interrupting the permanent life (suffix PD, QD, RD and TD).

NOTE 9.: If during normal use the reset button is pressed, the gas valves close and the S4565 starts a new sequence after releasing the reset button.

Suffix AD and PD (see fig. 32.)

When there is a call for heat a self check period (T_c) plus waiting period (T_w) elapse before the built-in igniter and gas valve are switched on.

The ignition spark ignites gas and resulting flame is detected by the flame rod.

After flame establishment a predetermined, extended ignition time can be included.

If flame is not established within the safety time (T_s), the S4565 ignition control locks-out.

If the flame is lost during normal run, the S4565 ignition control repeats start sequence.

Suffix BD and QD (see fig. 33.)

As AD and PD except flame relay contact or opto is activated after flame detection.

NOTE 10.:The hour counter is energized when the valve is energized. It can be used as an output signal.

Suffix CD and RD (see fig. 34.)

When there is a call for heat, self check period (T_c) plus waiting period (T_w) elapse when the air proving switch is in the no air position.

After $T_c + T_w$ the fan starts running.

When sufficient air flow is proven by the air proving switch, the built-in igniter and gas valve are switched on.

The ignition spark ignites gas and resulting flame is detected by the flame rod.

After flame establishment a predetermined, extended ignition time can be included.

If flame is not established within the safety time (T_s), the S4565 ignition control locks-out.

If the flame is lost during normal run, the S4565 ignition control repeats start sequence.

If no air is proven by the air proving switch, the ignition control stays waiting (optional lock-out on no air can be included).

Suffix DD and TD (see fig. 35.)

As CD and RD except flame relay contact or opto is activated after flame detection.

Suffix SD (see fig. 29.)

If line voltage is applied between pin 5 (line valves) and pin 9 (N), the gas valve is switched on.

If the line voltage is applied between pin 4 (line ignition) and pin 9 (N) the built in igniter is switched on.

The igniter circuit is fed during the negative half wave of the mains.

Pin 8 is present but not intended for use. It is connected with a resistor (100 Ω) to pin 5.

Ignition circuit must be on shorter than 10 s in an application with single ignition trial.

Gas/air application

For gas/air application without dynamic aircheck, the S4565AD, BD, PD or QD can be used.

In this application the fan is connected between pin 4 and 5 and will start when a call for heat is present. The waiting period now acts as a prepurge time.

When the call for heat disappears or when the ignition control goes in lock-out, the fan will be switched off.

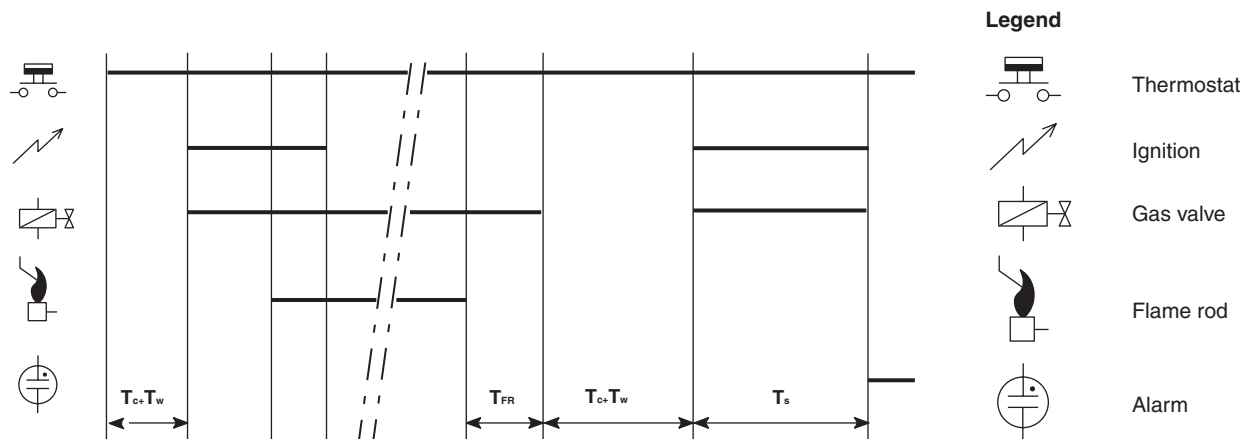

Fig. 32. Timing diagram S4565AD, PD "2000" series

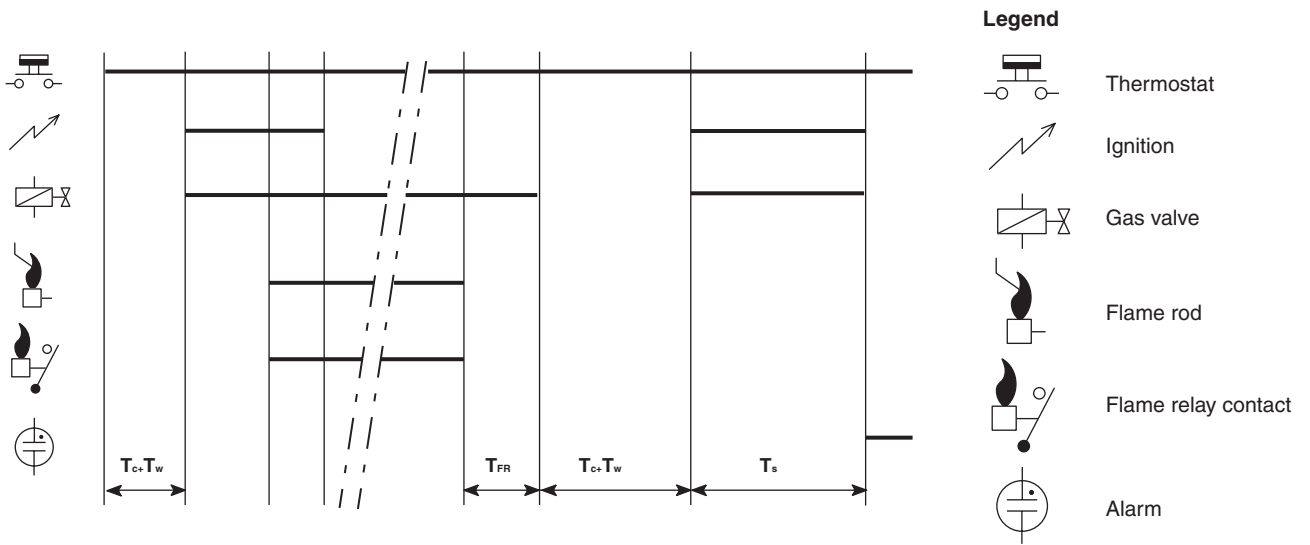

Fig. 33. Timing diagram S4565BD, QD "2000"series

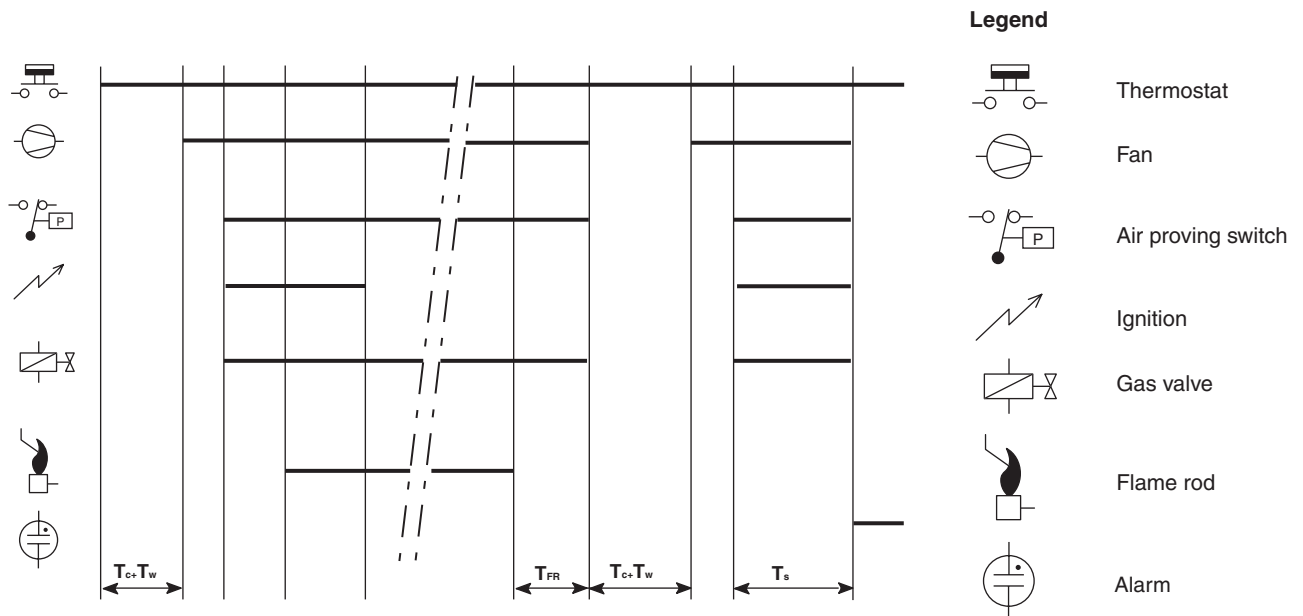

Fig. 34. Timing diagram S4565CD, RD "2000"series

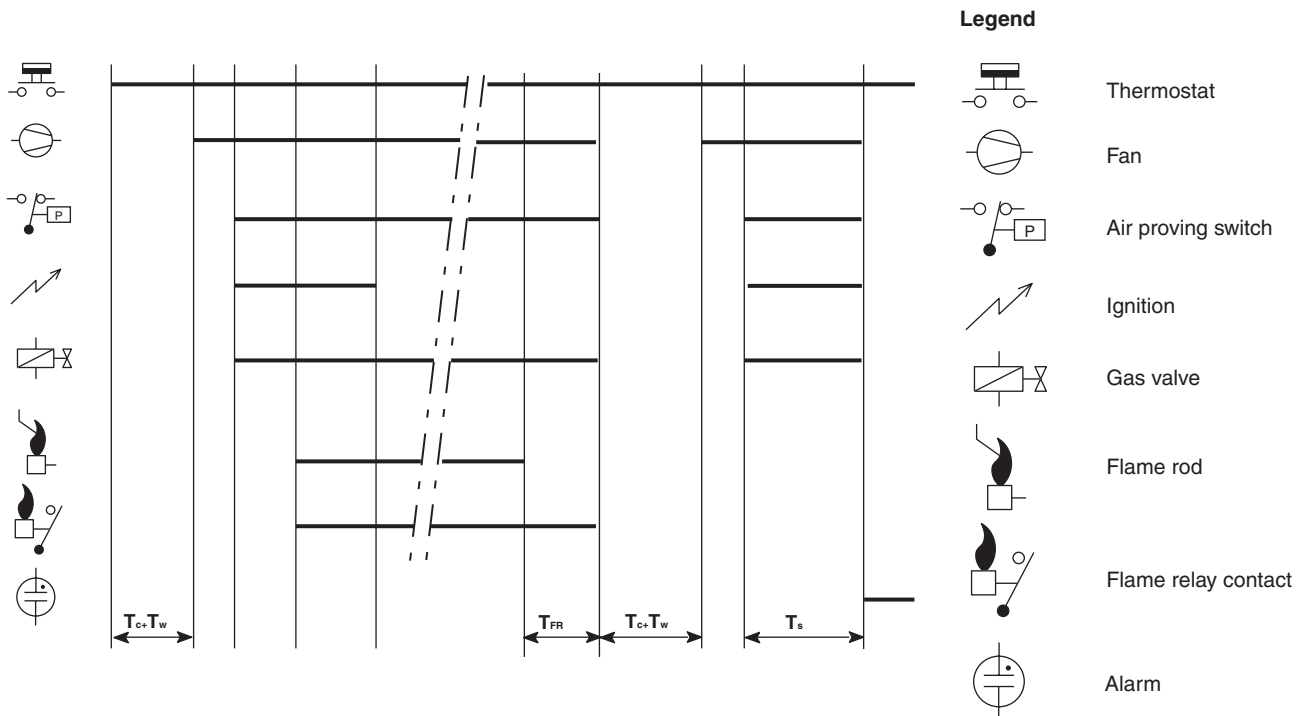

Fig. 35. Timing diagram S4565DD, TD "2000" series

SPECIFICATIONS IGNITION CONTROL S4565AF, BF, CF, DF, PF, QF, RF, TF

Model

Suffix AF: atmospheric, direct burner ignition
 Suffix BF: atmospheric, intermittent pilot burner ignition including safety timer
 Suffix CF: fan assisted, direct burner ignition
 Suffix DF: fan assisted, intermittent pilot burner ignition including safety timer
 Suffix PF: as AF except volatile lock-out
 Suffix QF: as BF except volatile lock-out
 Suffix RF: as CF except volatile lock-out
 Suffix TF: as DF except volatile lock-out

Supply voltage

220 ... 240 Vac, 50/60 Hz

Power consumption

4 VA

Humidity

90% RH max. at 40 °C

Ambient temperature

-15 ... 60 °C

Electrical rating (see also note 12. page 17)

Alarm: 220 ... 240 Vac, 50/60 Hz, 1 A, $\cos \varphi > 0.6$ or max 1mA
 Fan: 220 ... 240 Vac, 50/60 Hz, 1 A, $\cos \varphi > 0.6$
 LPG outdoor valve: 220 ... 240 Vac, 50/60 Hz, 1 A, $\cos \varphi > 0.6$
 Second main valve: 220 ... 240 Vac, 50/60 Hz, 1 A, $\cos \varphi > 0.6$

Electrical connection

High voltage spark: 2.8 mm spade terminal
 Optional: 4 mm round terminal
 Flame sensing: 4.8 mm spade terminal or 2.8 mm spade terminal for combined high voltage spark/flame sensing
 PCB connectors: Molex 3003 series suitable for Molex 3001 female cable connector

Housing (degree of protection)

See page 38

Timing (depending on O.S. number)

Self check time (T_C): 1.5 s
 Waiting time (T_W): 0 ... 30 s
 Safety time (T_S): 3.5 ... 55 s
 Extended spark ignition time and stabilisation time: 0 ... T_S (dependent on elaps of safety time)

External main burner interrupt

Max open contact voltage 24 V, max current 15 mA
 A low voltage relay is suitable.
 An opto coupler e.g. CNY17-3 is also possible
 A flame indicating series LED (see connection diagram) will conduct min 0.85 mA if the contact is open and minimal 3.5 mA if the contact is closed.

Flame sensing

Min flame current: 0.9 μ A
 Response time on: > 0.2 s
 Response time off (T_{FR}): < 1 s

Ignition

Spark voltage: > 12 kV at 40 pF load
 Spark energy: 3 ... 15 μ As
 Repetition rate: 2.5 ... 60 Hz (depending on O.S. number)
 Max spark gap: 3.5 mm

Length flame sensing cable
1 m max.

Length ignition cable
0.5 m max.

Length of wiring for external components
1 m max.

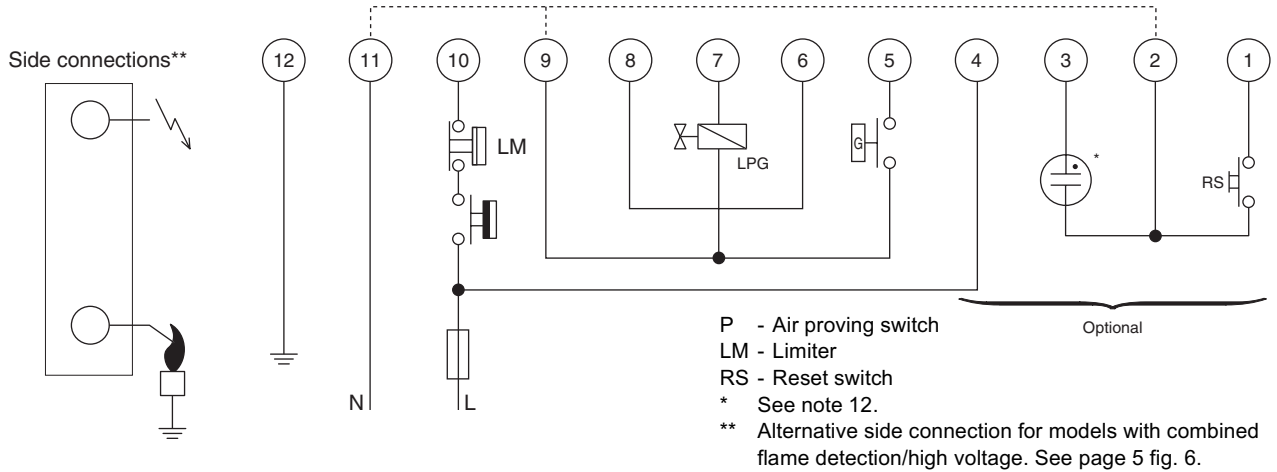

Fig. 36. Connection diagram S4565AF, BF, PF, QF

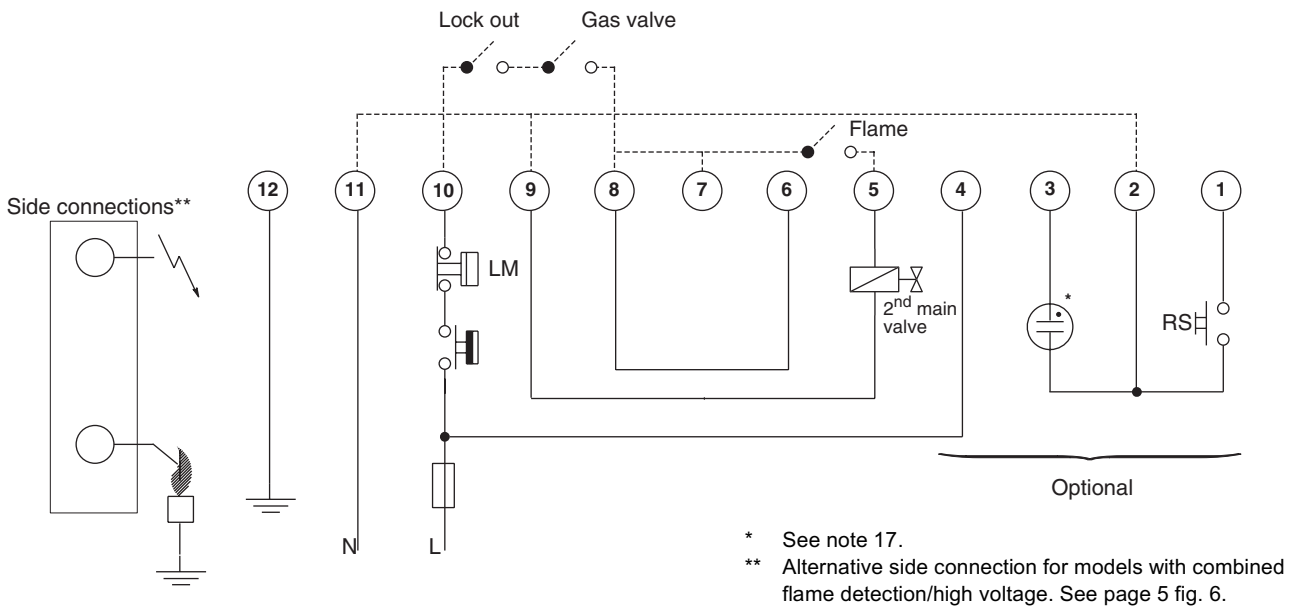

Fig. 37. Connection diagram S4565BF with second main valve control

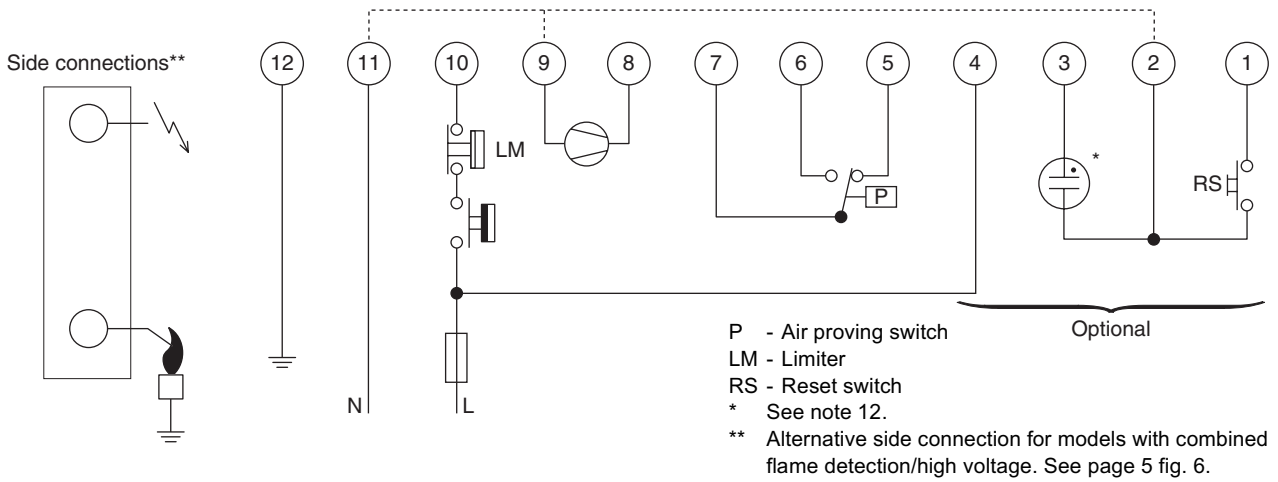

Fig. 38. Connection diagram S4565CF, DF, RF, TF

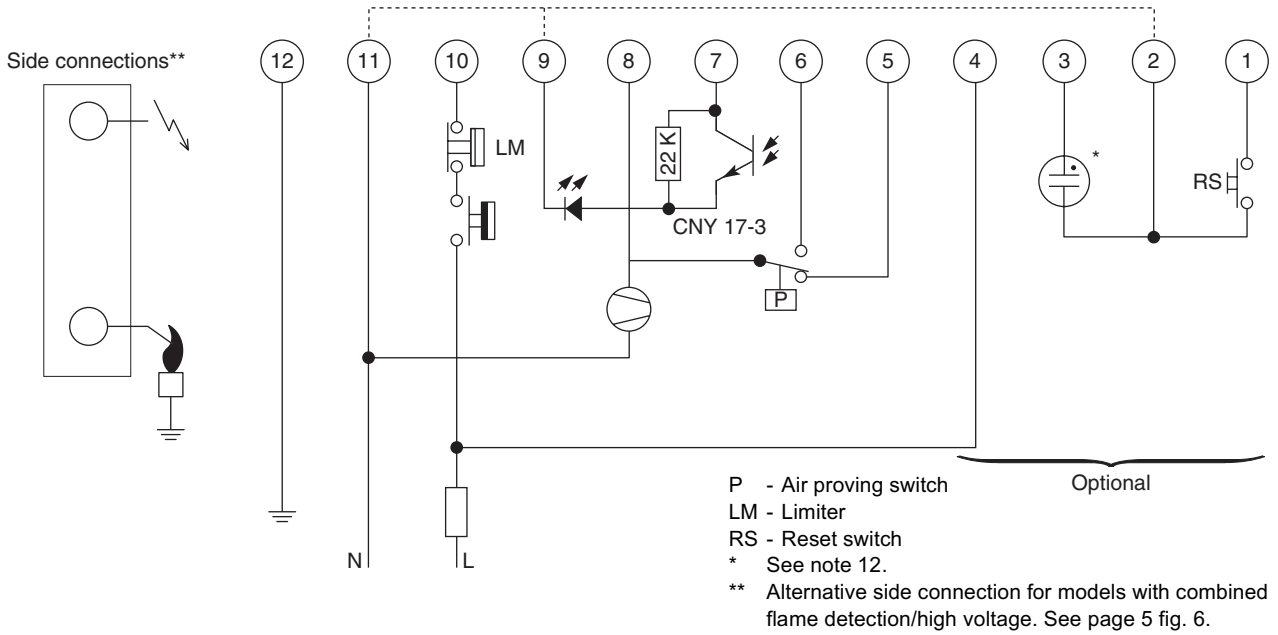

Fig. 39. Connection diagram S4565DF, TF with external main burner interrupt

SYSTEM OPERATION

General

Lock-out reset

The S4565 can be reset by either depressing the internal/external reset button (suffix AF, BF, CF and DF) or by interrupting the permanent life (suffix PF, QF, RF, and TF).

NOTE 11.: If during normal use the reset button is pressed, the gas valves close and the S4565 ignition control starts a new sequence after releasing the reset button.

NOTE 12.: If permanent alarm output: neon indicator with integral resistor >150 kΩ (max 1 mA)

NOTE 13.: If an external LPG valve and gas pressure switch are connected, the LPG valve is energized after call for heat. The ignition control stays in waiting mode, until the gas pressure switch is closed. If during normal operation the gas pressure switch opens, the gas valves will not be closed.

Suffix AF and PF (see fig. 40.)

When there is a call for heat a self check period (T_c) plus waiting period (T_w) elapses before built-in igniter and gas valve are switched on. The ignition spark ignites gas and resulting flame is detected by the flame rod. After flame establishment a predetermined, extended ignition time can be included. If flame is not established within the safety time (T_s), the S4565 ignition control locks out. If the flame is lost during normal run, the S4565 ignition control repeats start sequence.

Suffix BF and QF (see fig. 41.)

When there is a call for heat a self check period (T_c) plus waiting period (T_w) elapses before built-in igniter and pilot gas valve are switched on. The ignition spark ignites pilot gas and resulting flame is detected by the flame rod. After flame establishment a predetermined, extended ignition time can be included then the main valve is switched on. If flame is not established within the safety time (T_s), the S4565 ignition control locks-out.

If the flame is lost during normal run, the S4565 ignition control repeats start sequence.

Suffix CF and RF (see fig. 42.)

When there is a call for heat the fan starts running through the no air position of the air proving switch after a self check period (T_c) plus waiting period (T_w). When sufficient air flow is proven by the air proving switch, the built-in igniter and gas valve are switched on. The ignition spark ignites gas and resulting flame is detected by the flame rod. Ignition is switched off after a predetermined extended ignition time and flame establishment. If flame is not established within the safety time (T_s), the S4565 ignition control locks out. If the flame is lost during normal run, the S4565 ignition control repeats start sequence. If no air is proven by the air proving switch within the safety time (T_s), the ignition control locks-out.

Suffix DF and TF (see fig. 43.)

When there is a call for heat the fan starts running through the no air position of the air proving switch after a self check period (T_c) plus waiting period (T_w). When sufficient air flow is proven by the air proving switch, the built-in igniter and pilot gas valve are switched on. The ignition spark ignites pilot gas and resulting flame is detected by the flame rod. Ignition is switched off after a predetermined extended ignition time (T_{ext}) and flame establishment and then the main valve is switched on. If flame is not established within the safety time (T_s), the S4565 ignition control locks-out. If the flame is lost during normal run, the S4565 ignition control repeats start sequence. If no air is proven by the air proving switch within the safety time (T_s), the ignition control locks-out. If the internal main burner interrupt is activated (relay contact opened or opto transistor de-activated) the main valve drops off, but the pilot flame stays present.

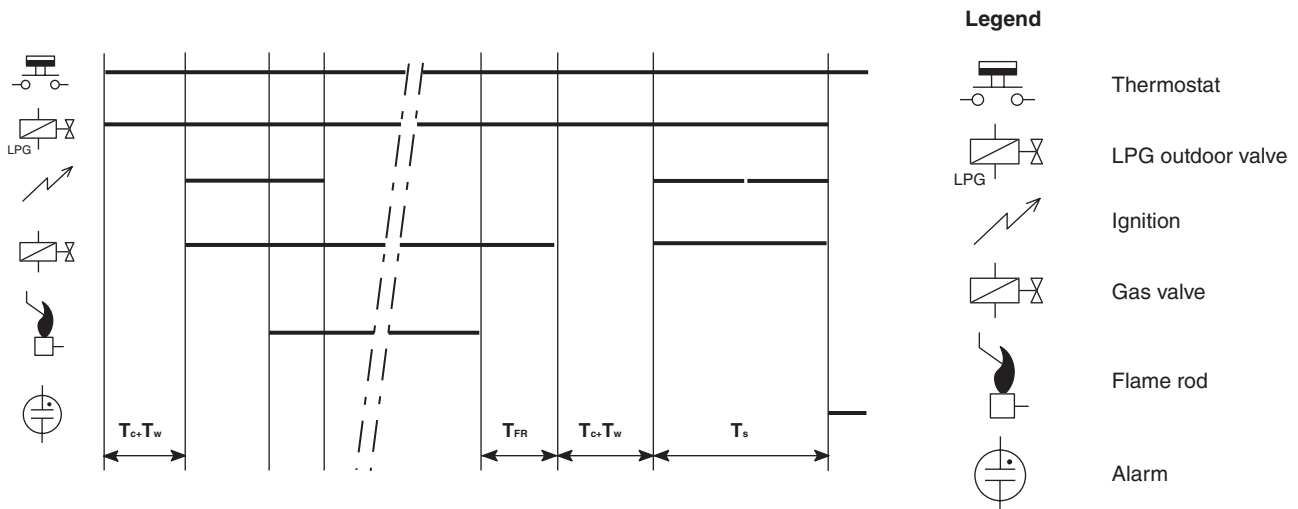

Fig. 40. Timing diagram S4565AF, PF

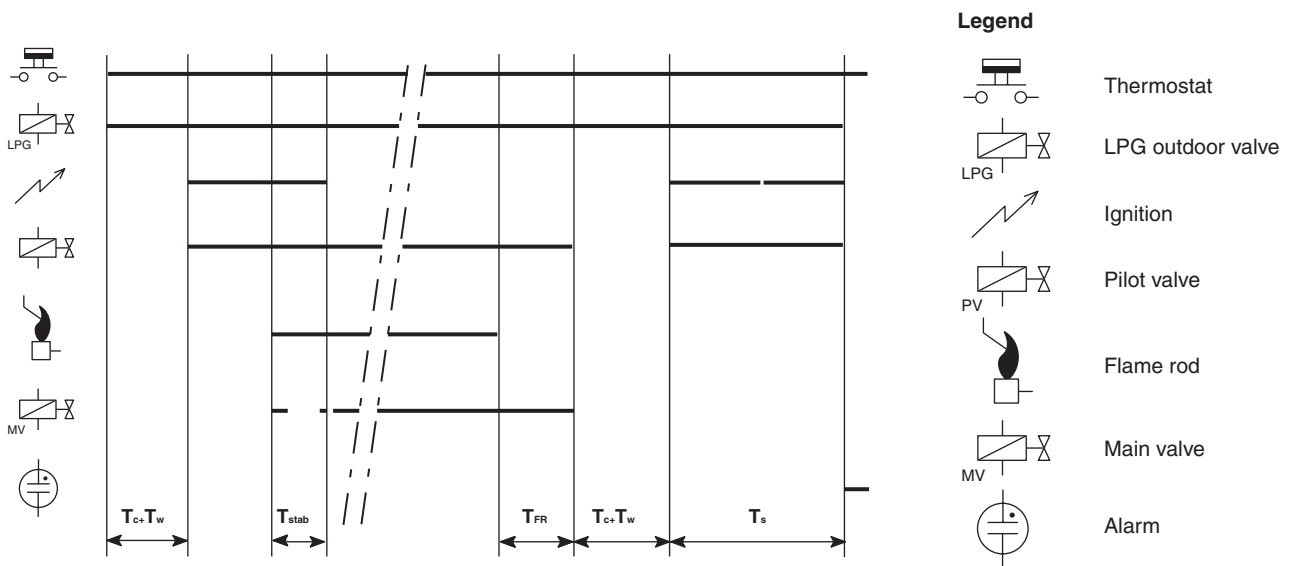

Fig. 41. Timing diagram S4565BF, QF

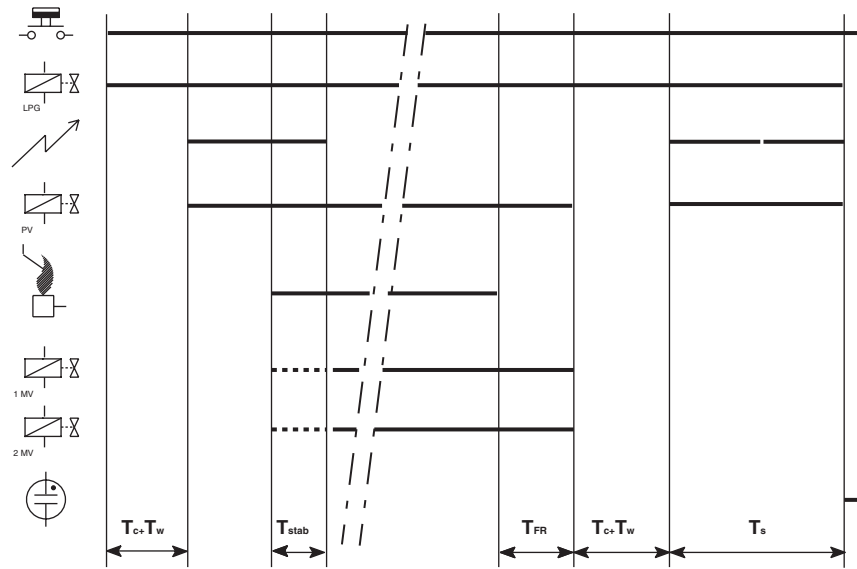

Fig. 42. Timing diagram S4565BF with second main valve control

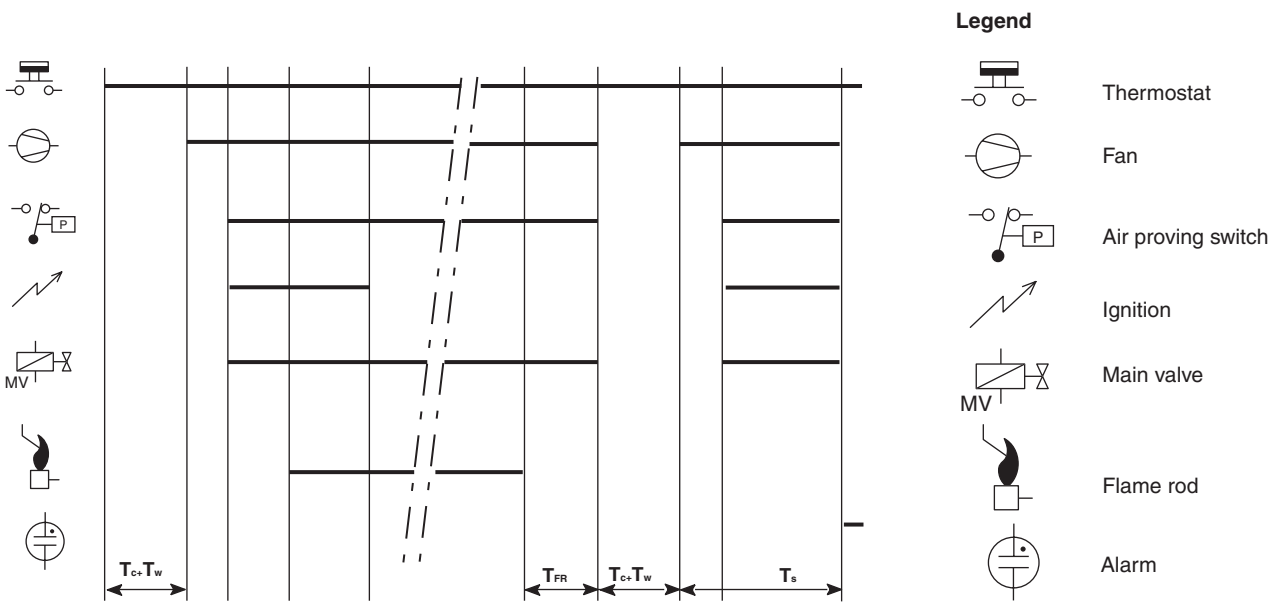

Fig. 43. Timing diagram S4565CF, RF

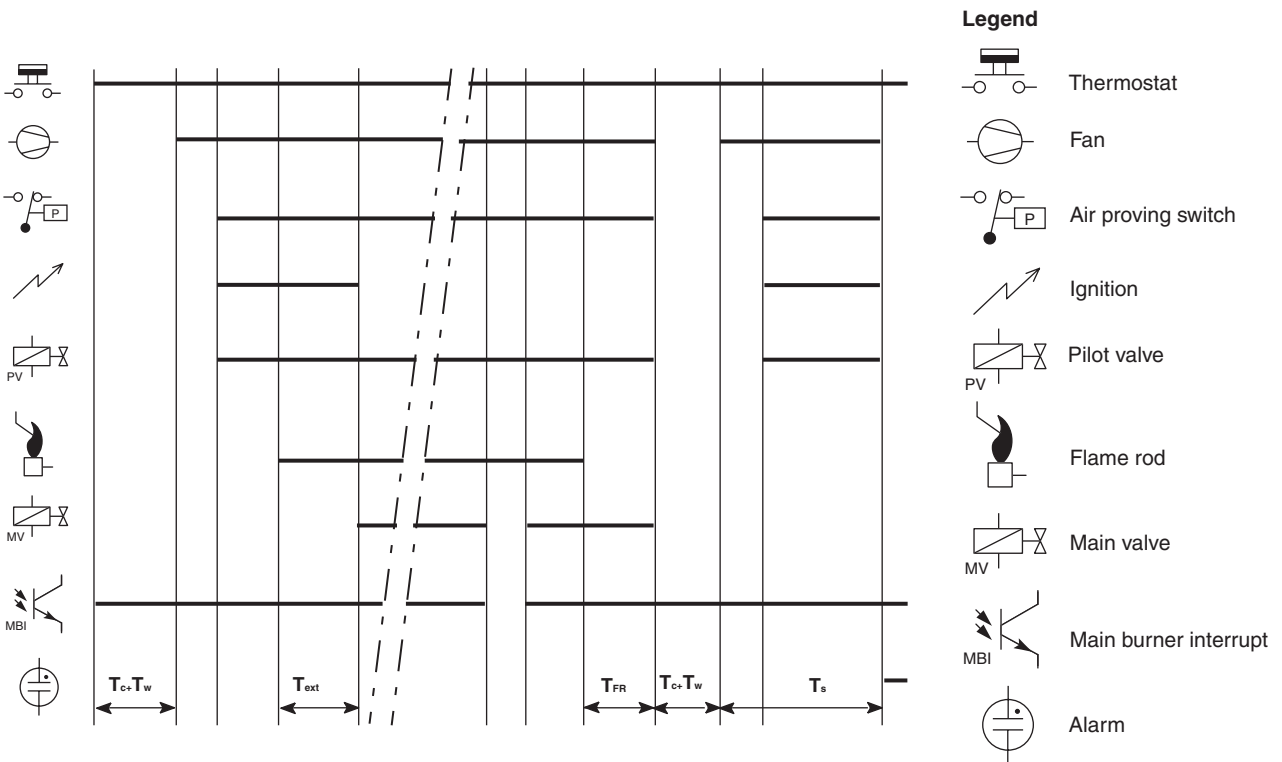

Fig. 44. Timing diagram S4565DF, TF

SPECIFICATIONS IGNITION CONTROL S4565PV, QV, RV, TV

General

The S4565PV, QV, RV, TV are multitrial volatile ignition controls in accordance with EN 298. The S4565RV and TV are fan assisted versions with or **without prepurge**, (reset by means of interrupting the permanent live or by a reset switch).

Non volatile lock-out of S4565PV, QV, and S4565RV, TV **without prepurge** are obtained if the status output is used to store the lock-out status in the comfort boiler control e.g. with the use of EEPROM. (see fig. 51.)

The alternative S4565RV, TV versions **with prepurge** option do not contain an independent manual reset function, (reset by means of interrupting the heat demand).

Model

Suffix PV: atmospheric, direct burner ignition, volatile lock-out

Suffix QV: as PV but with status or flame relay output

Suffix RV: fan assisted, direct burner ignition, volatile lock-out

Suffix TV: as RV but with with status or flame relay output

Supply voltage

230 Vac, 50/60 Hz

Power consumption

4 VA

Humidity

90% RH max. at 40 °C

Ambient temperature

-15 ... 60 °C

Electrical rating (see also note 14. page 27)

Fan: 230 Vac, 50/60 Hz, max 1 A, max $\cos \varphi > 0.6$

Flame relay contact: 230 Vac, 50/60 Hz, max 1 A, $\cos \varphi > 0.6$

Gas valve: 210 Vdc, 50 mA

Reset switch: 15 Vdc, 200 mA, **live part!!!!**

Status opto coupler: open collector +5 V, 10 k Ω
 logic "1" = 0 V
 logic "0" = 5 V
 "50 Hz" = block signal between 0 V and 5 V with about 50% duty cycle.

External igniter (optional): suitable for AC1A199.01 only, 230 Vrac 6 mA, **not accessible (IP 00)**

Electrical connection

High voltage spark: 2.8 mm spade terminal

Flame sensing: 4.8 mm spade terminal

PCB connectors: Molex 3003 series suitable for Molex 3001 female cable connector

Gas valve: intended for use onto VK41.. series gas controls



CAUTION

VK41.. gas control needs to be properly earthed by means of the external faston connection on the top of the gas control.

Housing (degree of protection)

See page 38

Timing (depending on O.S. number)

Self check time (T_C): 0 ... 2 s

Waiting time (T_W): 0 ... 15 s

Prepurge time (T_P): 0 ... 15 s

Safety time (T_S): 3 ... 10 s

Number of start trials: 1, optional 2 or 3; 2 or 3 only in combination with appropriate waiting or prepurge time

Flame sensing

Min flame current for phase

dependent systems: 0.9 μ A

Response time on: > 0.2 s

Response time off (T_{FR}): < 1 s

Ignition

Spark voltage: > 15 kV at 40 pF load (depending on O.S. number)

Spark energy: 5 ... 15 μ As (depending on O.S. number)

Repetition rate: 15 Hz

Maximum spark gap: 3.5 mm

Length flame sensing cable

1 m max.

Length ignition cable

0.5 m max.

Length of wiring for external components

1 m max.

Remark

Optional integrated flame relay available with safe separation or opto coupler with safe separation according EN 60730.



WARNING

Opto coupler interface needs a debounce time > 500 ms in order to prevent noise caused by transients on mains or by status transitions.

Opto coupler status output

- After heat demand during waiting time (T_W) or prepurge time (T_P) the status signal must be logic "0".
- After the waiting time (T_W) and without flame the status signal must be logic "1".
- After flame detection the status signal must be "50 Hz".
- If after the safety time (T_S) there is no flame detection, the ignition control goes to volatile lock-out. The status signal is logic "0".
- If high limit (LM) opens during operation the status signal becomes logic "0". The ignition control makes a restart but the status signal stays logic "0" during the safety time (T_S). This is the high limit indication status. The ignition control goes to volatile lock-out. The comfort boiler control has to store this status in a semi permanent memory in order to achieve non volatile lock-out. Line voltage interruptions may not cause data loss.

Table 1. Status output

Normal sequence	"0" - "1" - "50 Hz"
No flame sequence	"0" - "1" - "0"
High limit sequence during retrieval	"0" - "0" - "0"

Side connection*

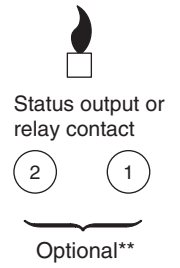
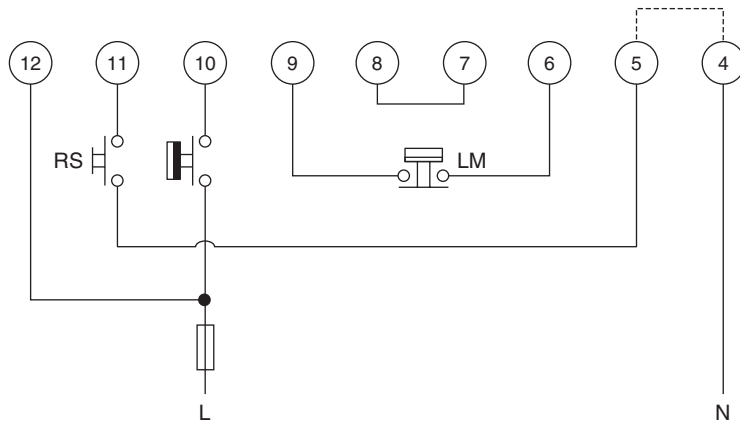
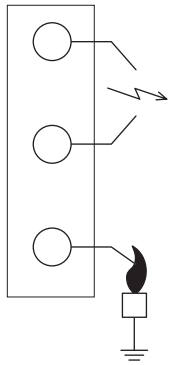

* See page 27 fig. 49.
** See page 10 fig. 18.

Fig. 45. Connection diagram S4565PV and QV series or connection diagram S4565RV and TV series wired in atmospheric applications

Side connection*

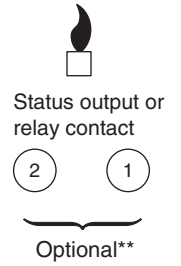
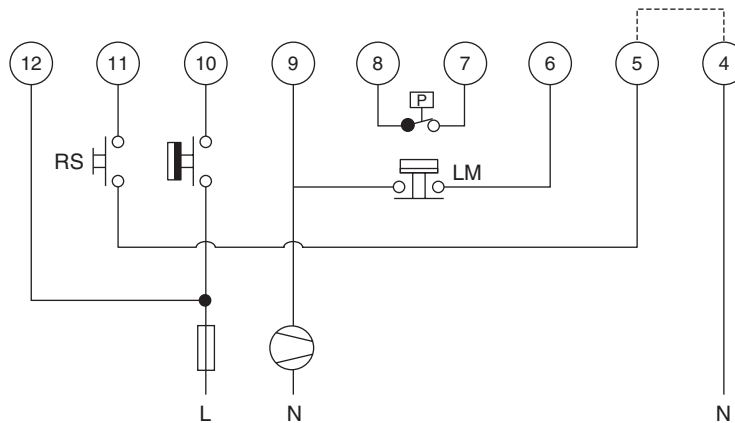
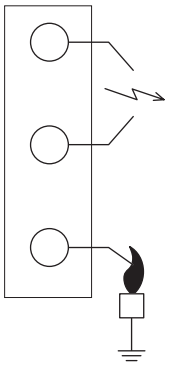

* See page 27 fig. 49.
** See page 10 fig. 18.

Fig. 46. Connection diagram S4565RV and TV series

Side connection*

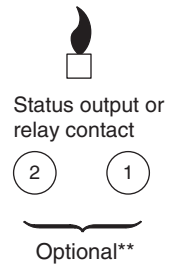
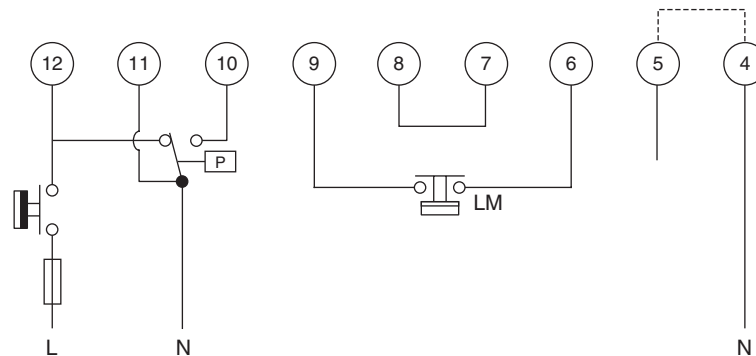
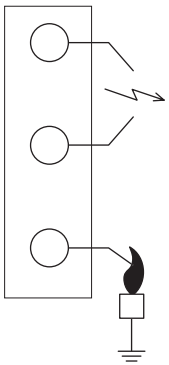

* See page 27 fig. 49.
** See page 10 fig. 18.

Fig. 47. Connection diagram S4565RV and TV with prepurge option

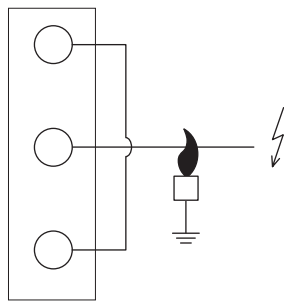

Fig. 48. Alternative side connection in case of combined flame sensing and sparking

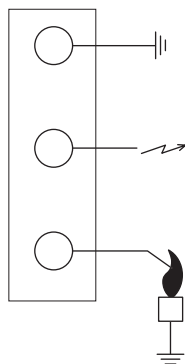

Fig. 49. Alternative side connection in case of sparking to ground

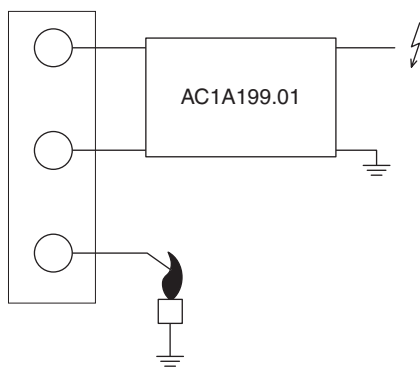

Fig. 50. Alternative side connection for external AC1A199.01 igniter

SYSTEM OPERATION

General

The S4565PV, QV, RV, TV ignition controls can provide closed-loop sparking, sparking to ground or combined sparking and flame sensing.

Lock-out reset

The S4565PV, QV, RV, TV ignition controls can be reset by interrupting the permanent live or by pressing the reset button for at least 1 s.

The S4565RV, TV versions with prepurge can be reset by interrupting the heat demand for at least 1 s.

The application of this type of control is therefore restricted to those applications where resetting by switching off the heat demand is allowed by European appliance standards. Reset of an appliance in lock-out must occur by means of a conscious manual action and not by means of automatic devices like thermostats or timers

NOTE 14.:If permanent alarm output:

neon indicator with integral resistor >150 kΩ

Suffix PV (see fig. 52.)

When there is a call for heat a self check period (T_c) plus waiting period (T_w) elapse before the built-in igniter and gas valve are switched on. The ignition spark ignites gas and resulting flame is detected by the flame rod.

After flame establishing a predetermined, extended ignition time can be included.

If flame is not established within the safety time (T_s), the ignition control locks out or makes a restart depending on the number of start trials.

If the flame is lost during normal run, the ignition control repeats start sequence.

Suffix QV (see fig. 53.)

As PV except flame relay contact or opto coupler is activated after flame detection.

Suffix RV (see fig. 54.)

When there is a call for heat a self check period (T_c) elapses if the air proving switch is in the no air position.

After T_c the fan starts running.

When sufficient air flow is proven by the air proving switch, the built-in igniter and gas valve are switched on.

The ignition spark ignites gas and resulting flame is detected by the flame rod.

After flame establishing a predetermined, extended ignition time can be included.

If flame is not established within the safety time (T_s), the ignition control locks out or makes a restart depending on the number of start trials. This is including dynamic air check.

If the flame is lost during normal run, the ignition control repeats start sequence.

If no air is proven by the air proving switch, the ignition control stays waiting (optional lock-out on no air can be included).

Suffix TV (see fig. 55.)

As RV except flame relay contact or opto coupler is activated after flame detection.

Suffix RV with prepurge (see fig. 56.)

When there is a call for heat the fan starts running through the no air position of the air proving switch.

When sufficient air flow is proven by the air proving switch, a self check period (T_c) plus a prepurge period (T_p) elapse before the gas valve and the built-in igniter are switched on.

The ignition spark ignites gas and resulting flame is detected

by the flame rod.
 Ignition is switched off.
 After flame establishing a predetermined, extended ignition time can be included.
 If flame is not established within the safety time (T_s), the ignition control locks out or makes a restart at prepurge depending on the number of start trials.
 If the flame is lost during normal run, the ignition control repeats start sequence at prepurge.
 If no air is proven by the air proving switch within the prepurge time (T_p) the ignition control stays in waiting mode with fan running.

Suffix TV with prepurge (see fig. 57.)

As RV with prepurge except flame relay contact or opto coupler is activated after flame detection.

STATUS OUTPUT APPLICATION

The lock-out status data from the S4565PV, QV, RV, TV ignition controls can be read by the microprocessor in the comfort boiler control and stored in its EEPROM.
 The relay contact is controlled by the microprocessor and activates the S4565PV, QV, RV, TV.
 During the start sequence the status output gives status information of the S4565PV, QV, RV, TV.
 The status information can be found under chapter SPECIFICATIONS paragraph: "Opto coupler status output" on page 23.
 If the signal of the status output does not correspond to the specifications, the comfort boiler control can shut off the ignition control.

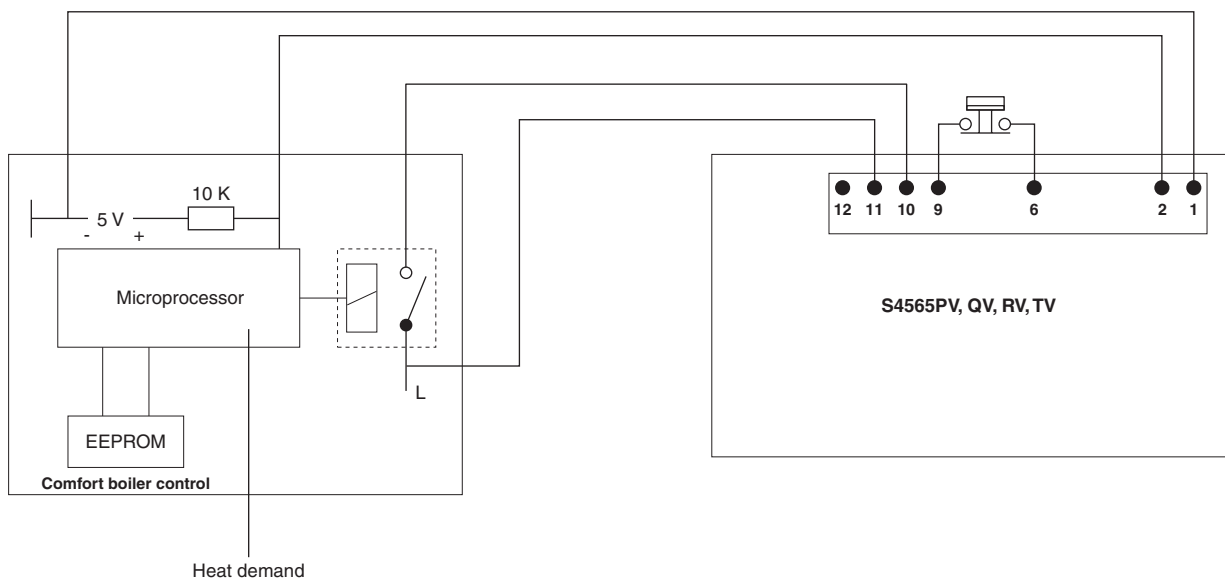

Fig. 51. Status output application

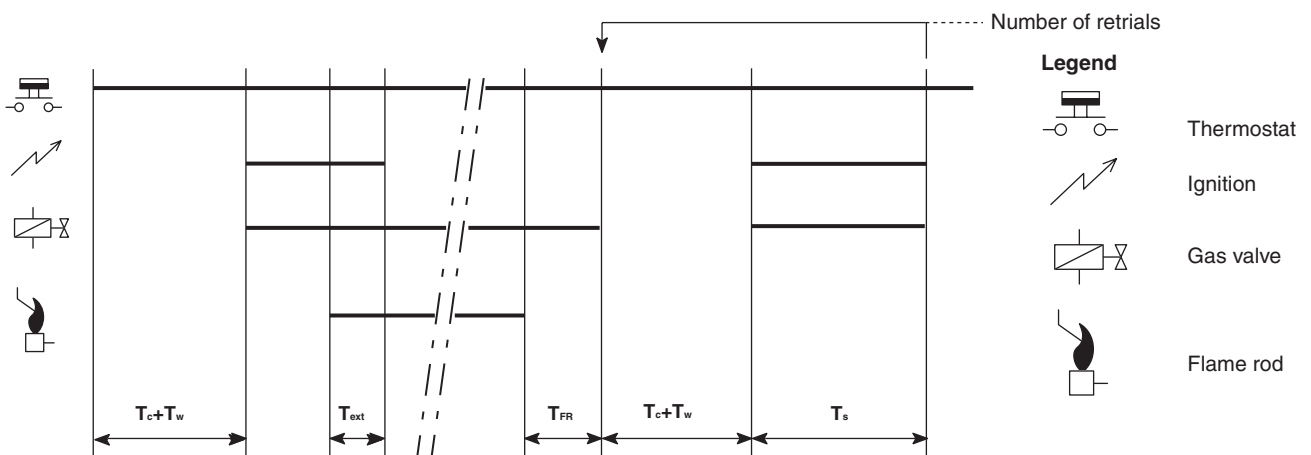

Fig. 52. Timing diagram S4565PV series

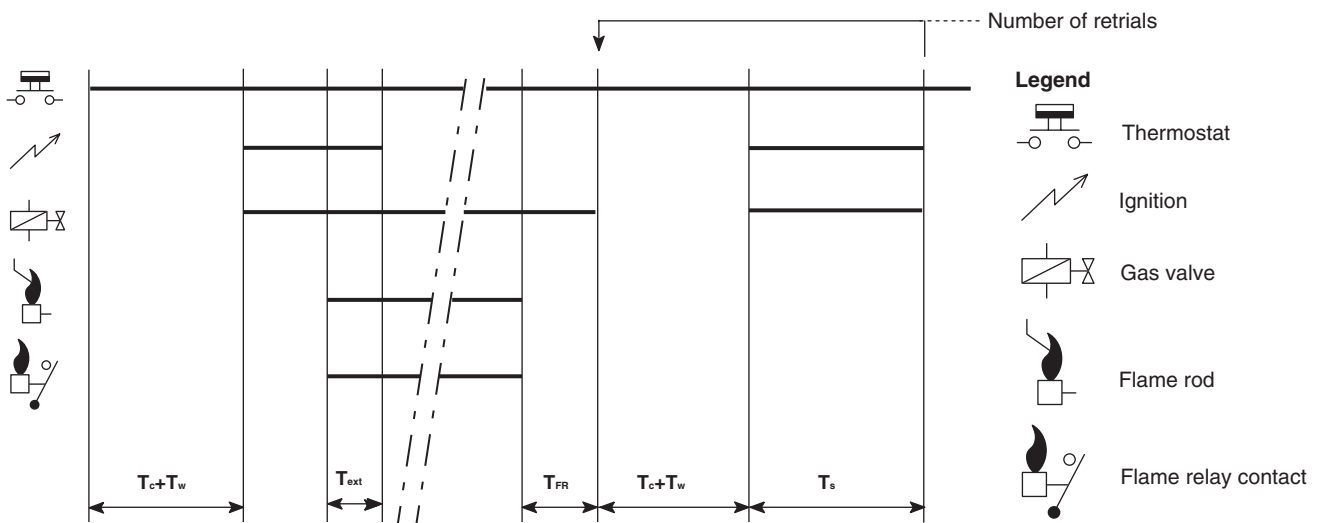

Fig. 53. Timing diagram S4565QV series

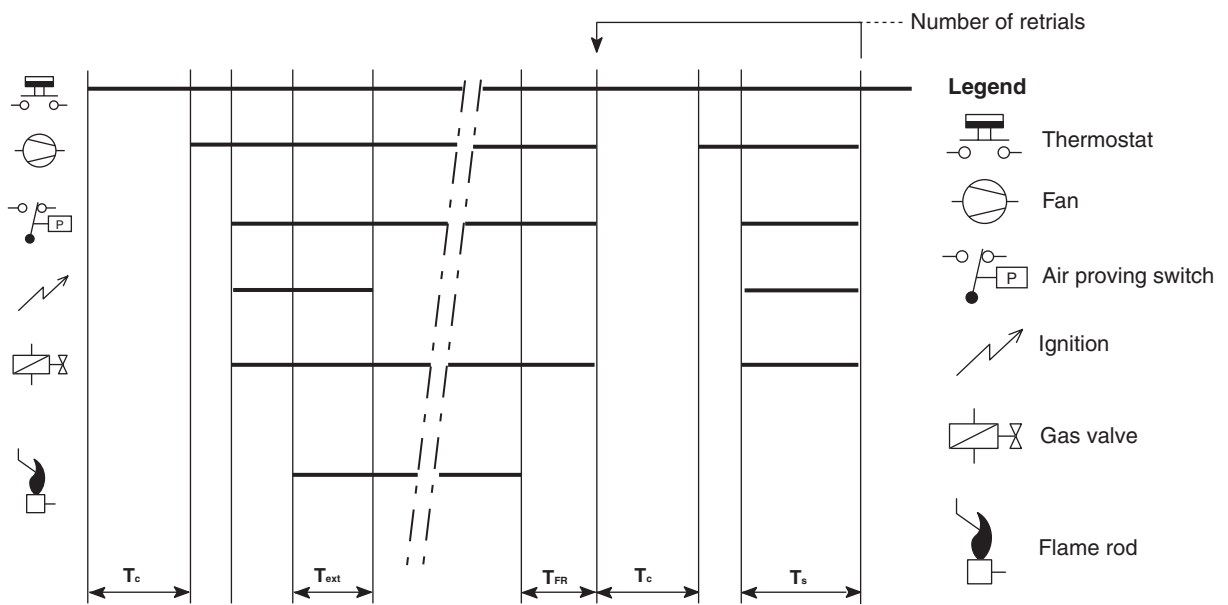

Fig. 54. Timing diagram S4565RV series

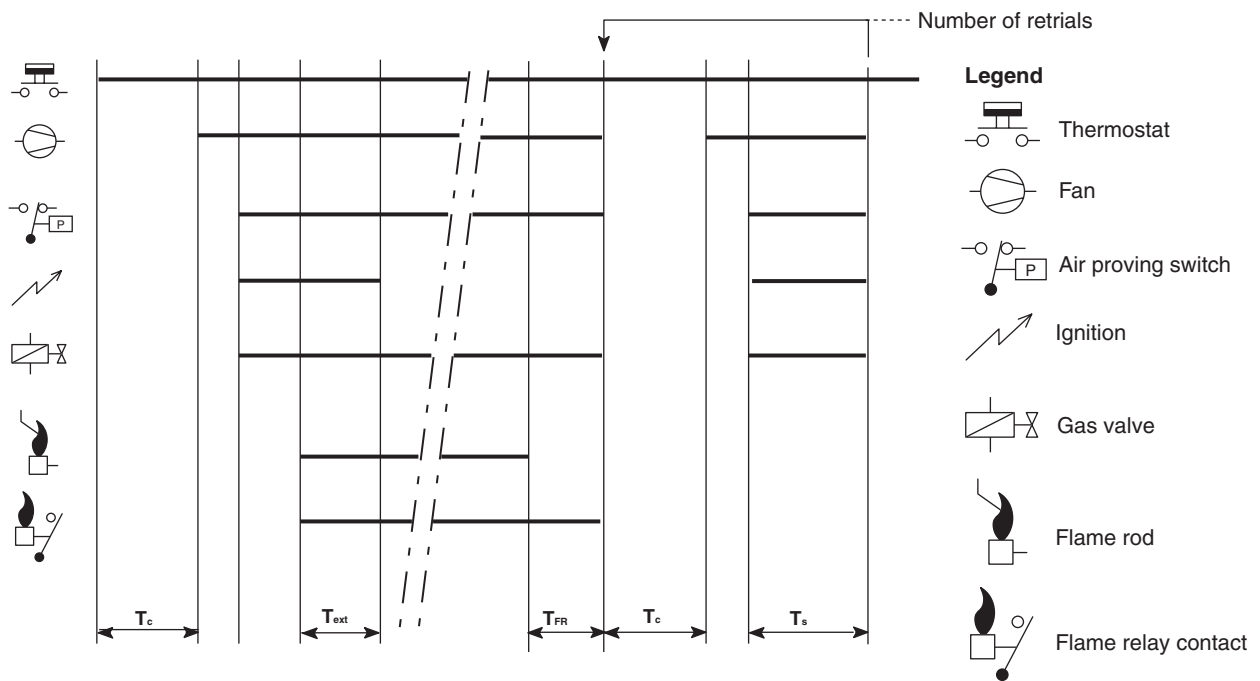

Fig. 55. Timing diagram S4565TV series

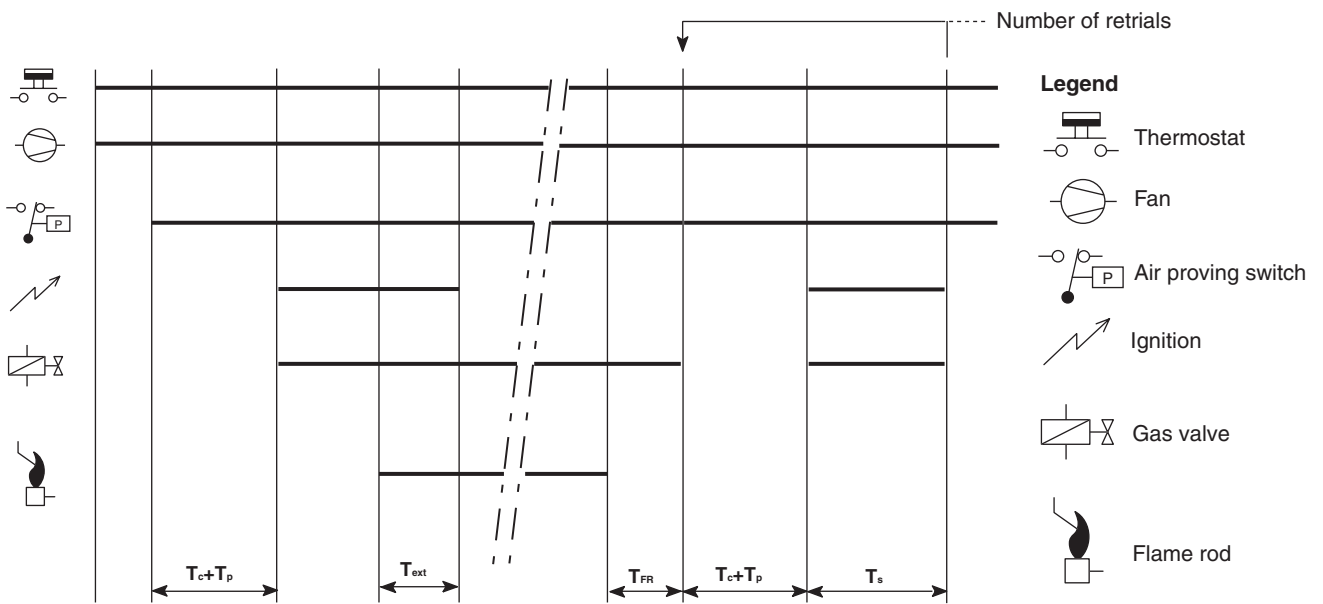

Fig. 56. Timing diagram S4565RV with prepurge

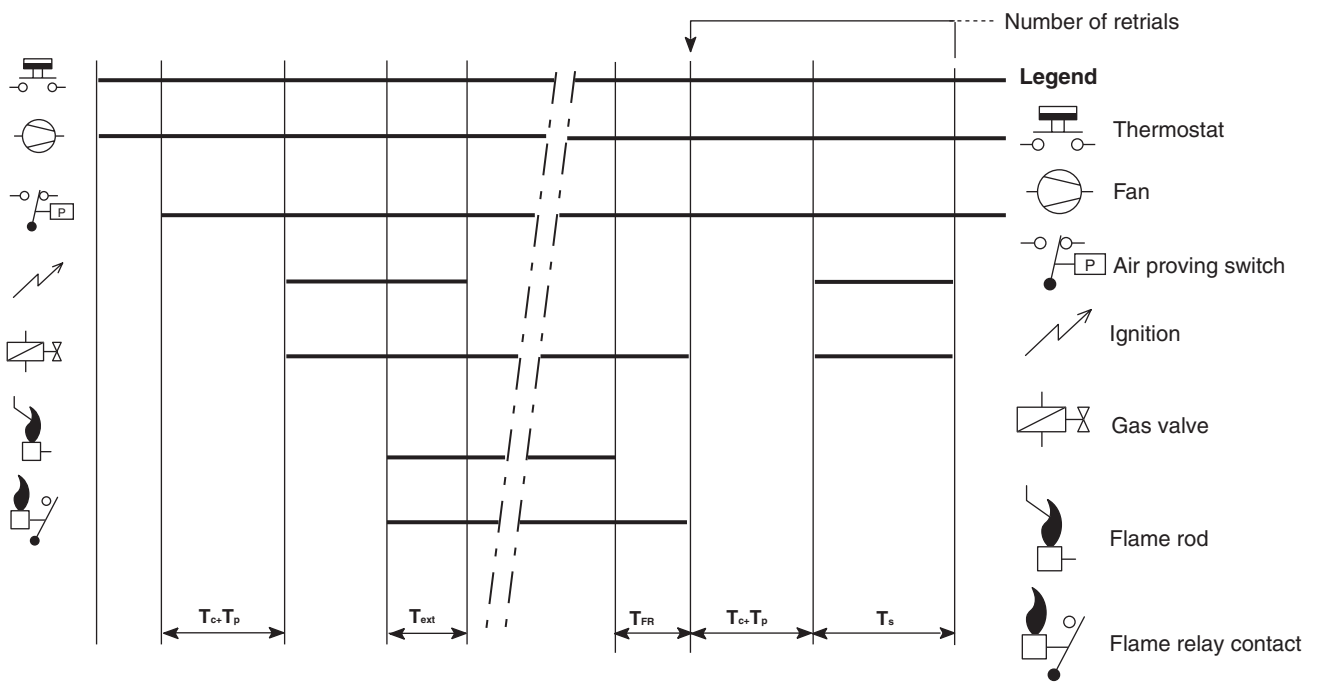

Fig. 57. Timing diagram S4565TV with prepurge

SPECIFICATIONS DIRECT BURNER IGNITION CONTROL S4575A, B, P, Q

Model

Suffix A: atmospheric, direct burner ignition
 Suffix B: as A but with flame relay output
 Suffix P: as A except volatile lock-out
 Suffix Q: as B except volatile lock-out

Supply voltage

230 ... 240 Vac, 50/60 Hz (-15%, +10%)

Power consumption

4 VA

Humidity

90% RH max. at 40 °C

Ambient temperature

-15 ... 60 °C

Electrical rating

Alarm: 230 ... 240 Vac, 50/60 Hz, max 1 mA
 Fan: 230 ... 240 Vac, 50/60 Hz, 1 A, $\cos \varphi > 0.6$
 Flame relay contact: 230 ... 240 Vac, 50/60 Hz, 1 A, $\cos \varphi > 0.6$
 Flame opto coupler: +5 V, 10 k Ω

Electrical connection

Hot surface ignition relay: 2.8 mm spade terminal
 Flame sensing: 4.8 mm spade terminal
 PCB connectors: Molex 3003 series suitable for Molex 3001 female cable connector

Housing (degree of protection)

See page 38

Timing (depending on O.S. number)

Self check time (T_C): 1.5 s
 Glowing time (T_g): 0 ... 30 s
 Safety time (T_s): 3.5 ... 25 s
 Extended ignition time: 0 ... T_s
 (dependent on elaps of safety time)

Flame sensing

Min flame current:
 for optional phase independent versions: 0.5 μ A
 for phase dependent versions: 0.9 μ A
 Response time on: > 0.2 s
 Response time off (T_{FR}): < 1 s

Hot surface ignition relay

Free contact: 230 ... 240 Vac, 2 A, $\cos \varphi = 1$
 24 Vac, 2 A, $\cos \varphi = 1$
 120 Vac, 2 A, $\cos \varphi = 1$



WARNING

Hot Surface Igniter (HSI) needs to be supplied from a floating winding of a transformer in order to guarantee reliable flame detection.

Length flame sensing cable

1 m max.

Length of wiring for external components

1 m max.

Remark

Optional integrated flame relay available with safe separation or opto coupler with safe separation.

N.C. contact of flame relay has no safe separation.



WARNING

Opto coupler interface needs a debounce time > 20 ms in order to prevent noise caused by transients on mains.

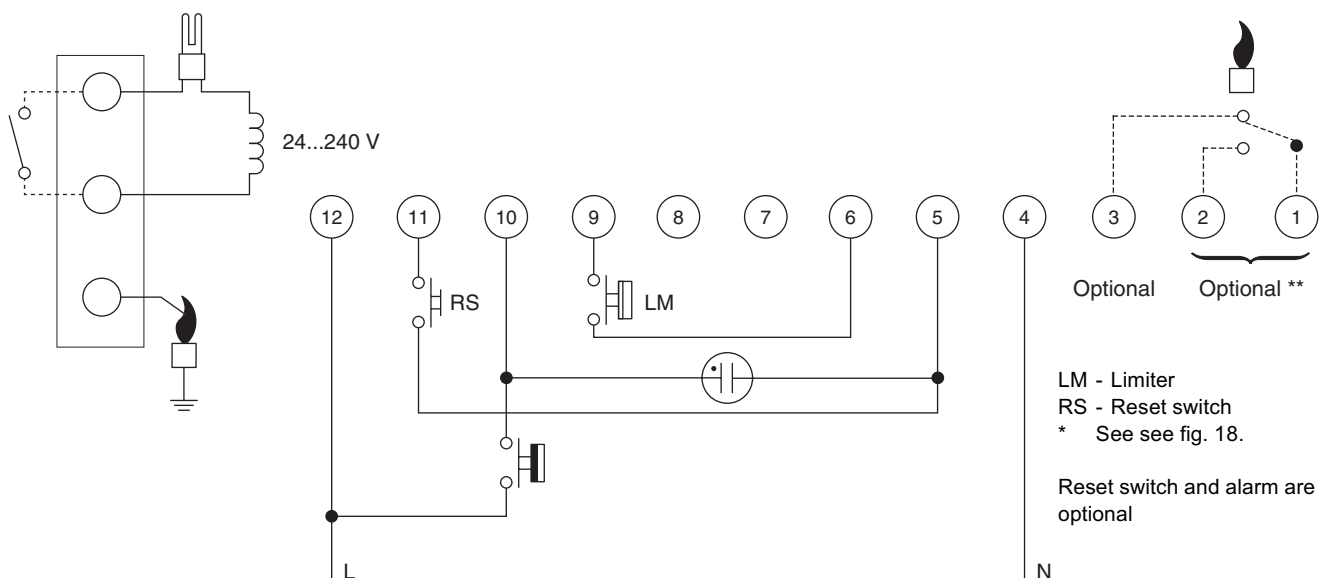

Fig. 58. Connection diagram S4575A, B, P and Q

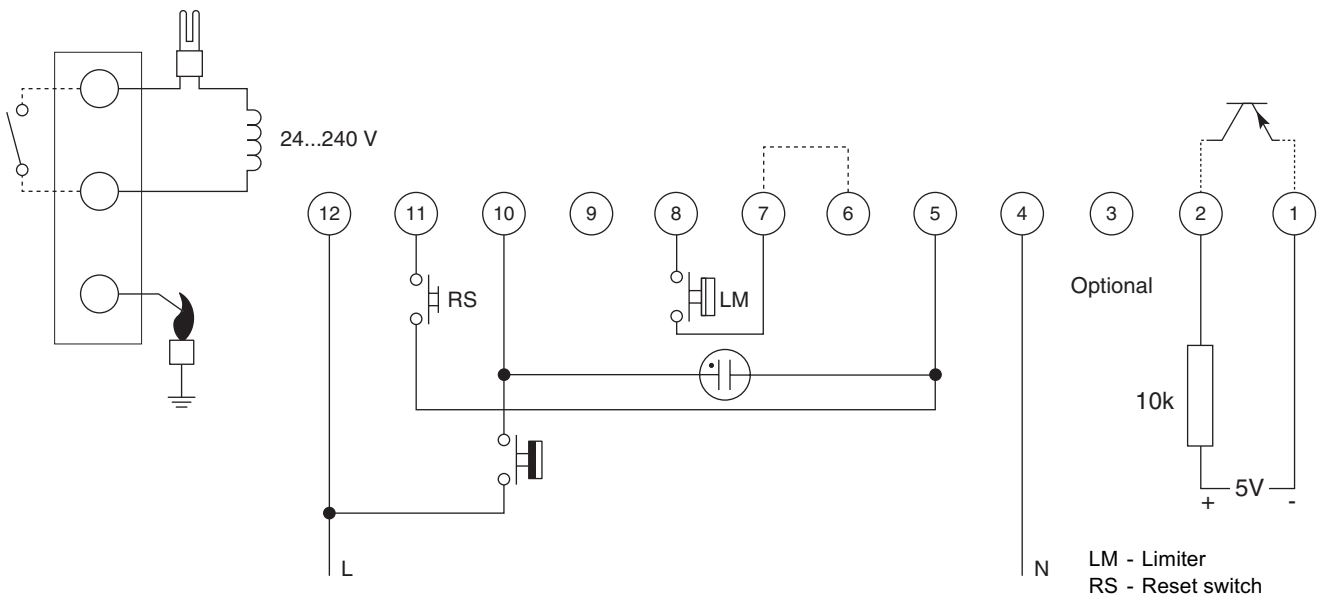

Fig. 59. Connection diagram S4575B 1009

SYSTEM OPERATION

General

The S4575A, B, P, Q ignition controls can provide hot surface ignition.

The **Hot Surface Igniter** (HSI is connected to a floating winding of a transformer (see fig 55., 56.).

Lock-out reset

The S4575 can be reset by either depressing the internal/external reset button (suffix A and B) or by interrupting the permanent life (suffix P and Q).

NOTE 15.:If during normal use the reset button is pressed, the gas valves close and the S4575 ignition control starts a new sequence after releasing the reset button.

NOTE 16.:If permanent alarm output: neon indicator with integral resistor >150 kΩ (max 1 mA)

Suffix A and P (see fig. 60.)

When there is a call for heat the HSI starts glowing during glowing time (T_g).

After the glowing time (T_g) the gas valve is switched on. The igniter ignites gas and resulting flame is detected by the flame rod.

After flame establishment a predetermined, extended ignition time can be included.

If flame is not established within the safety time (T_s), the S4575 ignition control locks out.

If the flame is lost during normal run, the S4575 ignition control repeats start sequence.

Suffix B and Q (see fig. 61.)

As suffix A and suffix P except flame relay contact is closed after flame detection.

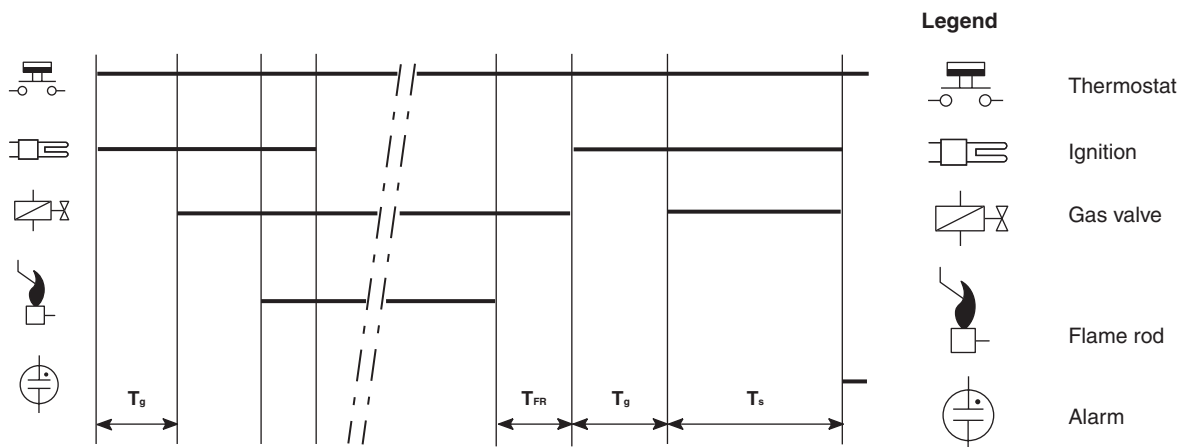

Fig. 60. Timing diagram S4575A, P

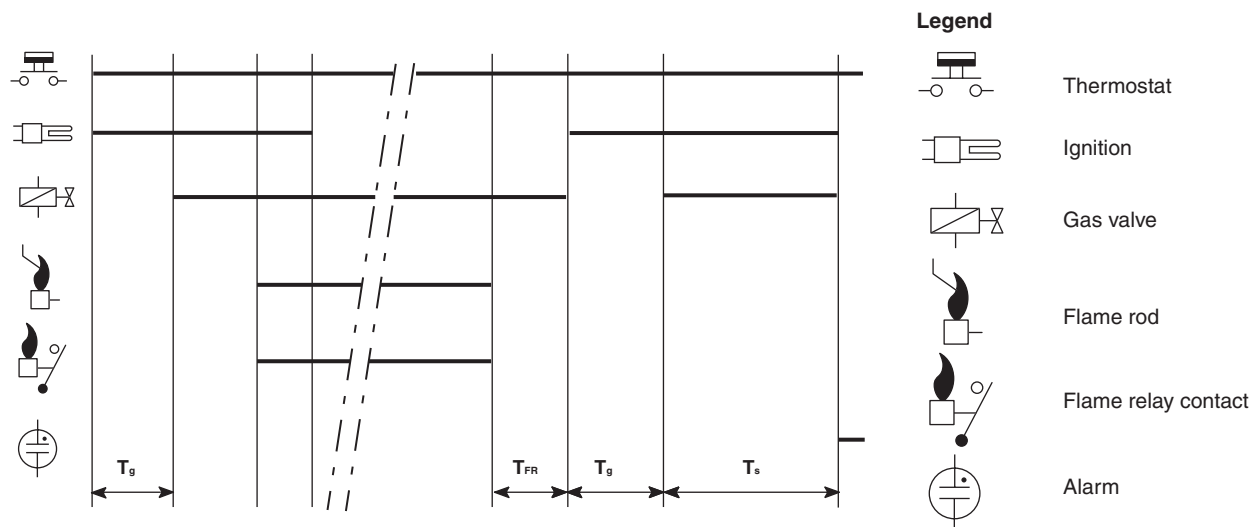

Fig. 61. Timing diagram S4575B, Q

SPECIFICATIONS INTERMITTENT PILOT IGNITION CONTROL S4585D

Model

Suffix D: fan assisted, intermittent pilot burner ignition

Supply voltage

220 ... 240 Vac, 50/60 Hz

Power consumption

4 VA

Humidity

90% RH max. at 40 °C non condensing

Ambient temperature

-15 ... 60 °C

Electrical rating

Fan: 220 ... 240 Vac, 50/60 Hz, 1 A,
cos φ > 0.6

No flame indicator: 220 ... 240 V, 1 mA max

Electrical connection

High voltage spark/flame

sensing single rod: 2.8 x 0.5 mm spade terminal

PCB connectors: Molex 3003 series suitable for
Molex 3001 female cable connector

Housing (degree of protection)

See page 38

Timing (depending of O.S. number)

Self check time (T_c): 1.5 s

Safety time (T_s): infinite

Flame sensing

Min flame current: 1.0 μ A

Response time on: > 0.2 s

Response time off (T_{FR}): < 1.0 s

Phase-Phase mains

trafo input: 220 ... 240 > 0.1 VA

Ignition

Spark voltage: > 12 kV at 40 pF load

Spark energy: 3 ... 15 μ As

Repetition rate: 1 ... 4 Hz

Max spark gap: 3.5 mm

Length ignition and flame sensing cable

0.5 m max.

Length of wiring for external components

1 m max.

Recommended flame sensor

Q371/Q385 "2000 series"/Q389/Q395 intermittent ignition
pilot burner

Maximum pilot burner output

250 Watt

No flame indicator

Required impedance: > 100 k Ω

No flame indication time

T_{NF} : > 10 s

Side connections**

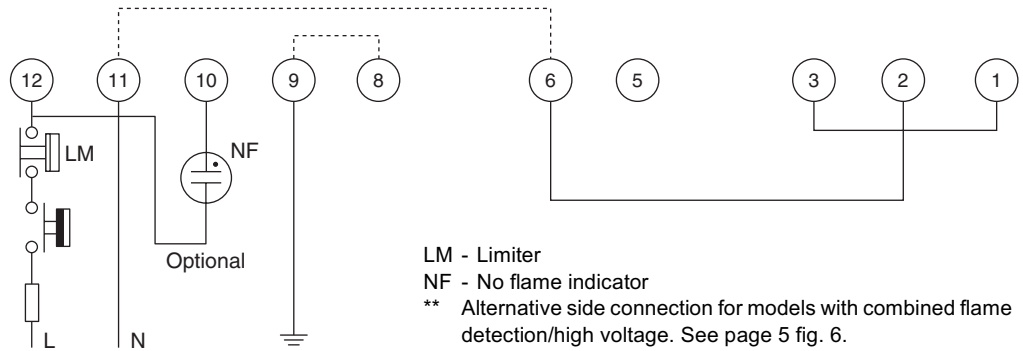
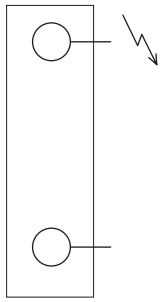

Fig. 62. Connection diagram S4585D wired up in atmospheric application

Side connections**

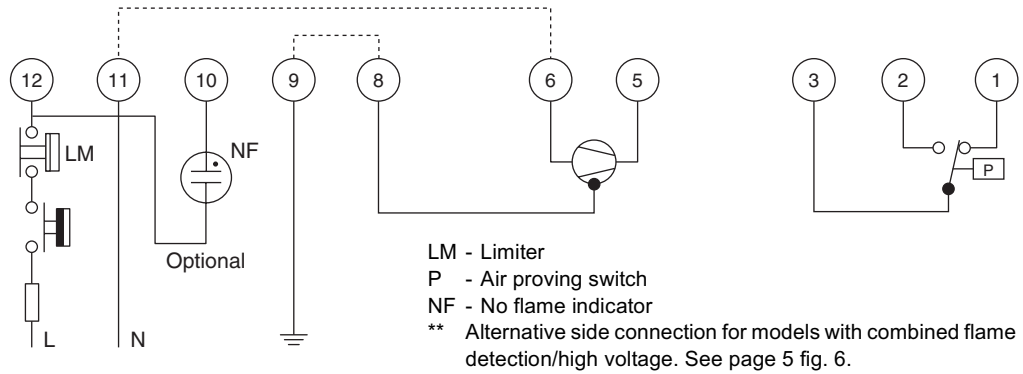
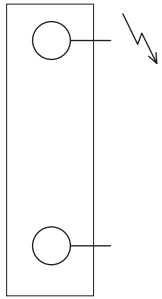

Fig. 63. Connection diagram S4585D wired up in fan assisted application

SYSTEM OPERATION

Atmospheric ignition control S4585D (see fig. 64.)

After false flame check during self check time (T_c) a built-in igniter and pilot gas valve are switched on. The ignition spark ignites gas and resulting flame is detected by the combined flame/ignition rod. Ignition is switched off immediately after flame is established and main gas valve is switched on. If the flame is lost during normal run, the main gas valve is closed and re-ignition of pilot occurs.

Fan assisted ignition control S4585D (see fig. 64.)

When there is a call for heat, fan is energized through no air proving switch after self check time (T_c). When sufficient air flow is proven by air proving switch, a built-in igniter and pilot gas valve are switched on. The ignition spark ignites gas and resulting flame is detected by the combined flame/ignition rod. Ignition is switched off immediately after flame is established and main gas valve is switched on. If air flow is not proven by air proving switch ignition control will remain in a waiting mode with fan energized. If the flame is lost during normal run, the main gas valve is closed and re-ignition of pilot occurs.

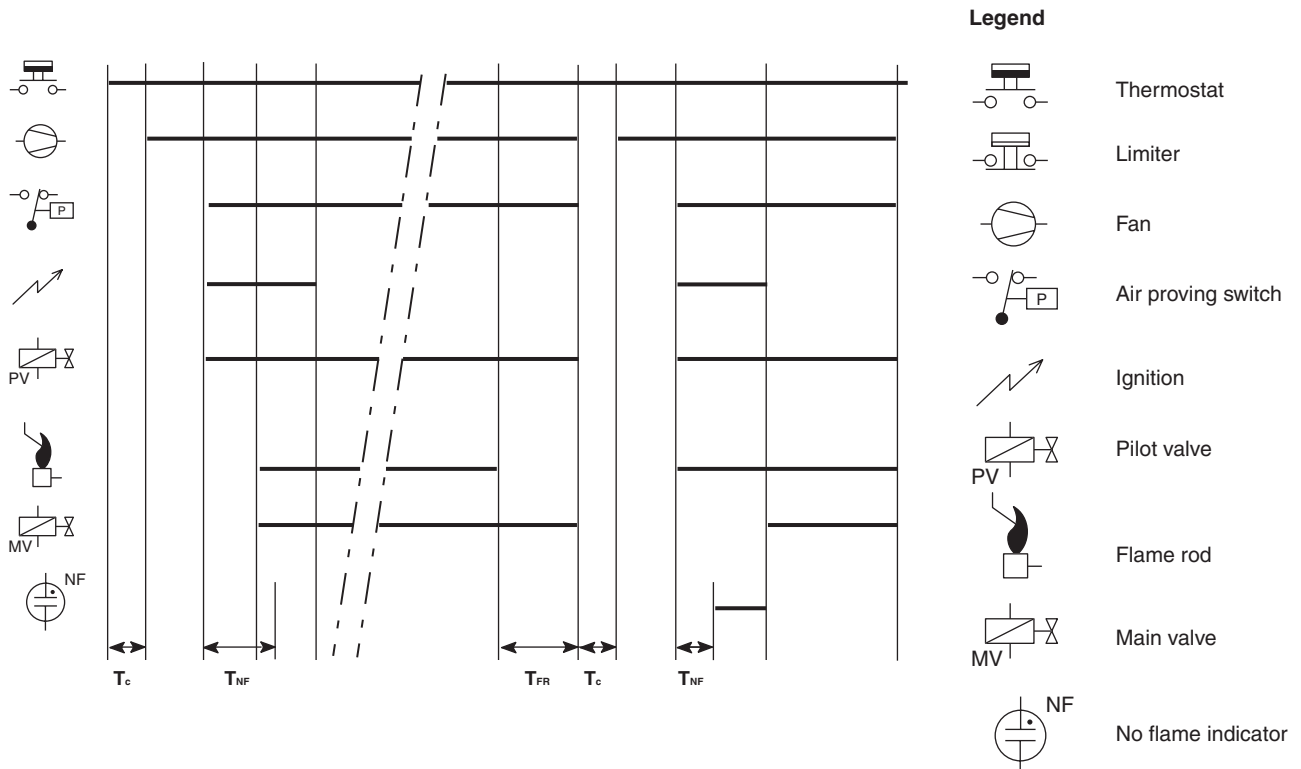

Fig. 64. Timing diagram S4585D

GENERAL CONSIDERATIONS

To ensure reliable long term operation, mount ignition control at a position in the appliance with a low ambient temperature and a low radiation.

High temperatures will affect product life.

To suppress Radio Interferency Interference (RFI) the ignition control including spark igniter cabling should be mounted in sufficient shielded environment.

NOTE 17.:When first starting, the control can be in the lock-out condition; reset the ignition control.

If a first reset is not succesful, wait at least 15 seconds before attempting another one.

After a reset an extended waiting time will occur.

NOTE 18.:Electrical rating of connected controls and air proving switch should be appropriate for the load that is switched by the ignition control.

NOTE 19.:Power interruptions will cause program restart.

NOTE 20.:The flame connection pin of all types is protected against electrical schock gas pressure switch as mentioned in this instruction sheet is a functional device.

NOTE 21.:If the S4565 ignition control incorporates an EMC filter, disconnect the ignition control from mains before performing a dielectric strength test.

No flame indication

If no flame indication is built in, the indicator ligths up if there is no flame detection within the no flame indication (T_{NF}) period.

ELECTRICAL CONNECTIONS AND WIRING

WARNING

Take care that installer is a trained experienced service person.
Turn off gas supply before starting installation.
Disconnect power supply to prevent electrical shock and/or equipment damage.

IMPORTANT

*Disconnect power supply to prevent electrical shock and/or equipment damage.
Wiring must be in accordance with local regulations. The appliance manufacturer's instructions should always be followed when provided. If such instructions are not provided see the connection diagrams for typical systems.
Before installing or replacing any control check that type number is correct for the application.
Ensure combustion chamber is free of gas before start up.
Conduct a thorough check out when installation is completed.
At the first start the ignition control can be in lock-out; depress reset button to free control.
Warranty claims are not accepted if the specified plug/rectifier circuit is not used.*

CAUTION

Do not connect the ignition control to power supply when it is not connected to the gas control.

Wiring

- Use leadwire which can withstand 105 °C ambient.
- Use leadwire which is proven against moisture.
- Wiring between ignition control and spark sensing probe should have good quality insulation, suitable for the temperatures encountered.

CAUTION

If ignition frequency ≥ 25 Hz or pulse energy > 45 μ As the ignition cable and its connections shall have a protection against electrical shock hazard.
For single rod applications, the ignition/sensing cable and its connections shall have protection against electrical shock hazard.
Label all wires prior to disconnection when servicing ignition controls. Wiring errors can cause improper and dangerous operation.
If electronics components are installed in an area subject to water (dripping, spraying, rain etc.), means shall be provided to protect these components.
Flame relay output is not accessible when the normally closed output is present.

Assembling of the cable connector(s) and cover (see fig. 65.)

- Use cable with $\varnothing 5 \dots \varnothing 7$ mm.
- Strip length cable: 15 mm
- Grommet inlet numbers 1, 2, 4 applicable for cable with $\varnothing 5 \dots \varnothing 7$ mm.

- Grommet inlet number 3 applicable for cable with $\varnothing 4 \dots \varnothing 7$ mm.
- Mount the connector(s) and bring the cable grommet in position over the cables and connector.

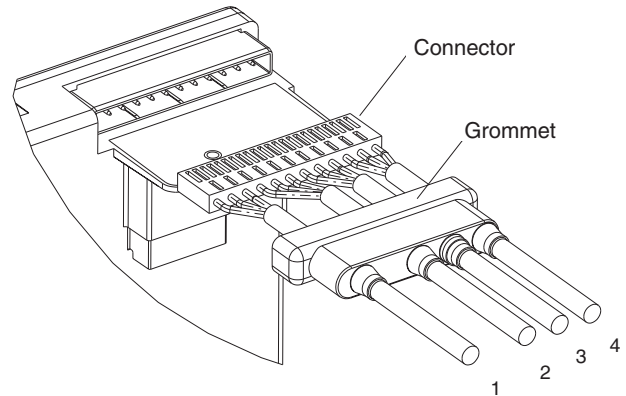

Fig. 65.

Assembly of strain relief for IP 44 protection (see fig. 66.)

Position the cover on the ignition control. Then, when holding the cover down (in direction A) rotate it to mount the cable(s) in the strain relief (in direction B). Finally fix the whole assembly (ignition control and cover) with a screw on the gas control with a torque of 40 Ncm max.

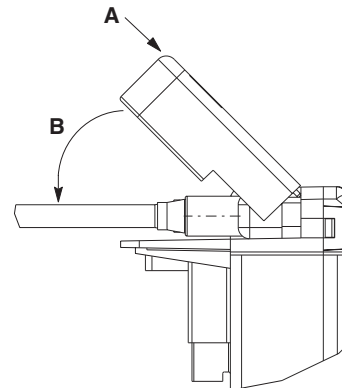

Fig. 66.

Fusing

In order to prevent unsafe conditions at too high current, the ignition controls have an integral non replaceable fuse. This fuse will be blown long before the maximum 16 A external fuse switches off.

Spark gap

Max. allowable spark gap 3.5 mm

Supply voltage polarity

WARNING

If ignition control (without the phase neutral independent operation feature) seems to operate normally but does not detect flame, check for right polarity of power supply (line, neutral).

Checking flame current

- The minimum value should be in accordance with specified value.
- To check flame current connect a DC micro-Ampèremeter between flame sensing wire and flame sensing rod.
- If flame current is insufficient check that flame sensing rod is fully enveloped by the flame and that burner is reliable grounded to the ignition control.
- If there is no sufficient flame current due to phase-phase mains it is recommended to use an ignition control with the phase neutral independent operation feature. If this is not available, it is recommended to use a AT7030A or AT7030B flame detection transformer. See also instruction sheet EN1R-9136 for the AT7030 transformer.



WARNING

Short μ A meter during ignition to prevent damage of the μ A meter in single rod application.

FINAL CHECKOUT

Final checkout of the installation

Set appliance in operation after any adjustment and observe several complete cycles to ensure that all burner components function correctly.

- To check flame current connect a DC micro-Ampèremeter between flame sensing wire and flame sensing rod.
- If flame current is insufficient check that flame sensing rod is fully enveloped by the flame and that burner is reliable grounded to ignition control.
- If there is no sufficient flame current due to phase-phase mains it is recommended to use an ignition control with the phase-neutral independent operation feature. If this is not available, it is recommended to use an AT7030A or AT7030B flame detection transformer. See also instruction sheet EN1R-9136 for AT7030 transformer.

Housing (degree of protection)

New style housing (see fig. 1.)

Enclosure IP 20 (standard housing)

Use: strain relief set 45.900.440-001

Enclosure IP40

Use: cover set 45.900.431-004
cover set 45.900.431 -005
(flame retardant according to UL94-VO)
cable grommet 45.900.442 -008

Enclosure IP 44 (only applicable for specific O.S. numbers)

Use: cover set 45.900.431-004
cover set 45.900.431 -005
(flame retardant according to UL94-VO)
cable grommet 45.900.442 -008/009
sleeve 45.900.442-003
gasket 45.900.442-011

Old style housing (see fig. 2.)

Enclosure IP 20 (standard housing)

Enclosure IP30

Use: strain relief set 45.900.440-001
cover set (external reset) 45.900.401-044
cover set (internal reset) 45.900.401-045

Enclosure IP40

Use: strain relief set 45.900.440-001
cover set (external reset) 45.900.401-044
cover set (internal reset) 45.900.401-045
grommet 45.900.442 -001 and -002
(depending on application and number of cables)

Enclosure IP 44 (on request)