

## FLOW SWITCHES FF82 FOR PIPES FROM G1 TO G8

### GENERAL CHARACTERISTICS

Flow switches are suitable to control and adjust air in conditioning. It acts in compliance with the technical regulations of the M.D. 1/12/1975 (Safety) standards for the instruments containing hot liquids under pressure) and with the collection R file R.2.C.6. Into heating plants with closed expansion tank where the circulation is guaranteed by electropumps, the heat supply must be automatically interrupted in case of stop of the circulation pumps.

### INSTALLATION

To be installed on sections of horizontal pipe, far from valves, elbows, irregular flows or discharges, the straight pipe must be at least 5 times of the long of the of the pipe. The flow direction must follow the arrow designed on the instrument.

- Respect installation distance as per (fig 1)
- Check the correct installation and the correct functioning, pushing the regulation screw to simulate flow (fig 2)

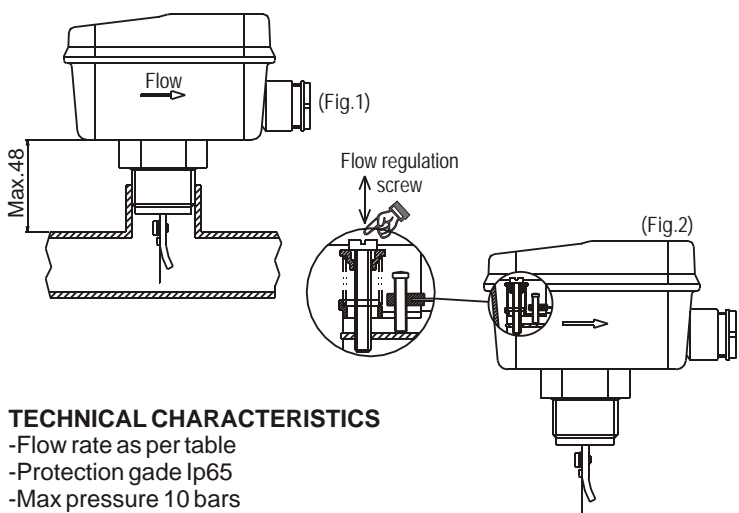

### TECHNICAL CHARACTERISTICS

- Flow rate as per table
- Protection gade Ip65
- Max pressure 10 bars
- Working temperature: -20 ÷110°C
- Ambient temperature: 50°C
- Antishock thermoplastic material enclosure
- Paddles in inox AISI 301 for pipes from G1 to G8
- G1" connection
- Female 6,3mm electrical connection
- Sealed cable glande **Pg16**

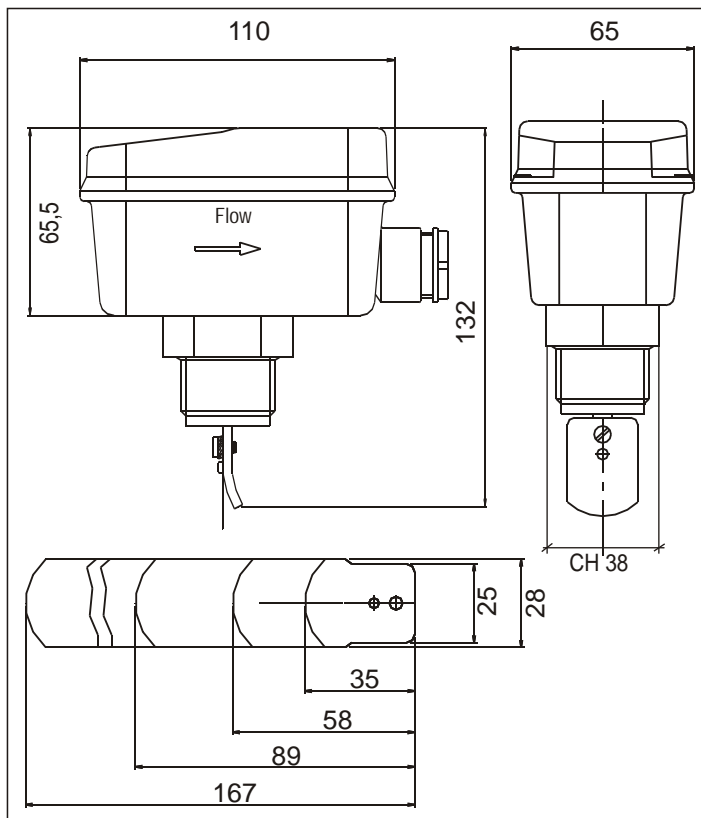

### ELECTRICAL FEATURE

SPDT microswitch  
Nominal tension: 250Vac  
Continuous duty nominal current: 16 (6) A

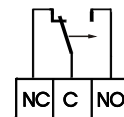

According to CEI EN 60947-5-1

CEI EN 60529

Flow increases: open C-NC  
Close C-NO

### CALIBRATION

Device is supplied with lower flow rate calibration;  
To modify it use use regulation screw as per **fig 3**

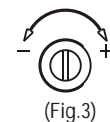

TYPE	PIPELINE DIAMETER	PADDLE mm	Minimum flow rate Value m <sup>3</sup> /h		Maximum flow rate Value m <sup>3</sup> /h	
			Decreasing	Increasing	Decreasing	Increasing
FF82	1"	35	0,5	1	1,9	2
	1" ¼	35	0,7	1,2	2,7	2,9
	1" ½	58	1	1,6	3,6	3,9
	2"	58	2,1	2,9	5,7	6,1
	2" ½	89	2,7	4	6,5	7
	3"	89	4,3	6,1	10,7	11,4
	4"	89	11,3	14,7	27,6	28,9
		* 167	6,1	7,9	17,3	18,4
	5"	89	22,8	28,3	53	55,5
		* 167	9,2	12,8	25	26,7
	6"	89	35,8	43	81,6	85
		* 167	12,2	16,8	30,5	32,5
	8"	89	72,4	85	165,5	172,3
		* 167	38,5	46,4	90,7	94

\*values using longer paddle

WE RESERVE THE RIGHT TO MAKE ANY NECESSARY TECHNICAL MODIFICATIONS WITHOUT ADVANCED NOTICE