

FAN04264

Pressure switches for single-phase / two-phase motors direct control

Pressure controls suitable to control directly the electric motors of the pumps, compressors, domestic or industrial autoclaves groups. Suitable as well for fluids (gas or liquids) chemically compatible with the friction diaphragm.

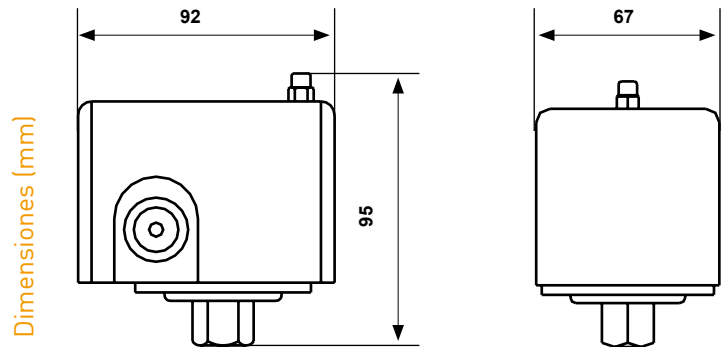

	Range bar	Differential range beginning bar	Differential range ending bar	Max. differential of the sensible element bar	Protection degree
B71	1,5 ÷ 4,5	1,0 ÷ 2,1	1,2 ÷ 2,3	6	IP40

1 Bar = 100Kpa *The differential must be deducted from the range value.

ELECTRICAL FEATURES

Double breaking switch for each pole, contacts in silver alloy.

EXAMPLE OF ELECTRICAL WIRING FOR DIRECT CONTROL OF THE ELECTRIC MOTOR

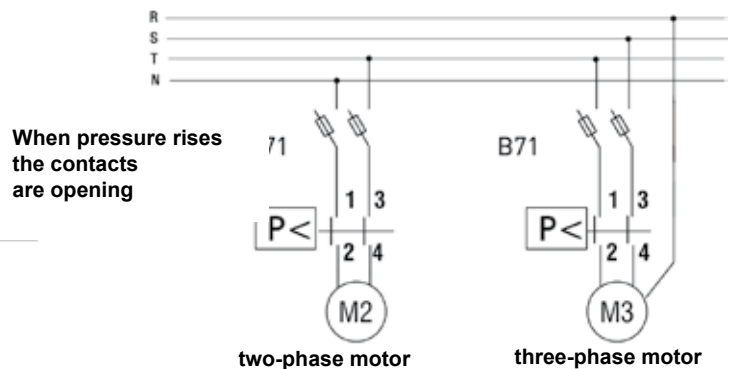

Nominal insulation tension	Ui 415V~
Continuous duty nominal current	Ith 15A
Operating nominal current in AC-1	Ie 12A
Operating nominal current in AC-3	Ie 3A

HOMOLOGATION AND STANDARDS

Complies with EN 60947-5-1 standards.

INSTALLATION

Direct installation on the pipe.

OPERATION

Contacts are opening when pressure rises.

Bipolar contact allows the control of electric motors up to 3A, without contactor.

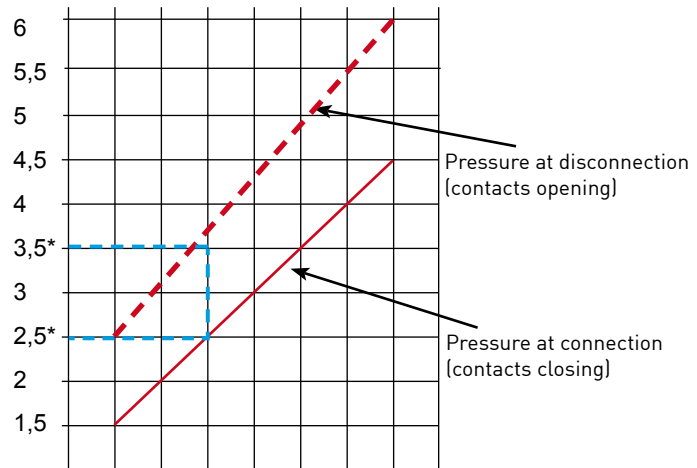

* EXAMPLE: Pressure at disconnection 3,5 bar
Pressure at connection 2,5 bar

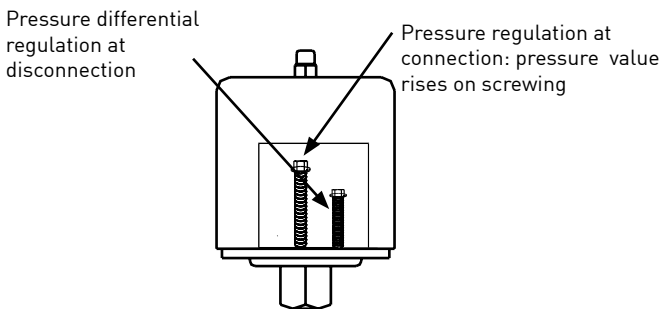

FEATURES

Sensitive element with friction membrane.

Adjustable differential.

Flange connection G 1/4.

Cover in shockproof thermoplastic material.

The metallic parts are in stainless steel.

Earth clamp.

Output connections with two cable glands.

Maximum temperature of the controlled fluid: 70°C.

Pressure switch body admissible temperature: -15 ÷ 60°C.

Storage and transport temperature: -15 ÷ 60°C.

Unit weight: 0,35 Kg.