

# FAN04152 à 58

## Hydrostats up to 1 bar

These devices are used for protection against lack of water in cooling systems. Suitable against lack of oil in lubrication circuits or lack of coolant in cooling systems. Pressure control is intended mainly for protection against boiling and combustion.

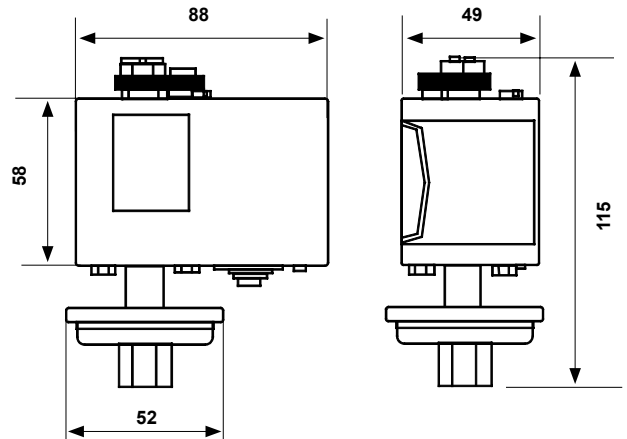

	Range bar	Differential bar	Sensitive element max. pressure bar	Connection G/14	Protection degree	Availability
B11AN	0,15 ÷ 1	0,1 fixed	20	flange	IP40	in stock
B11AN4	0,15 ÷ 1	0,1 fixed	20	threaded	IP40	on request

## WATERPROOF CASING EXECUTION

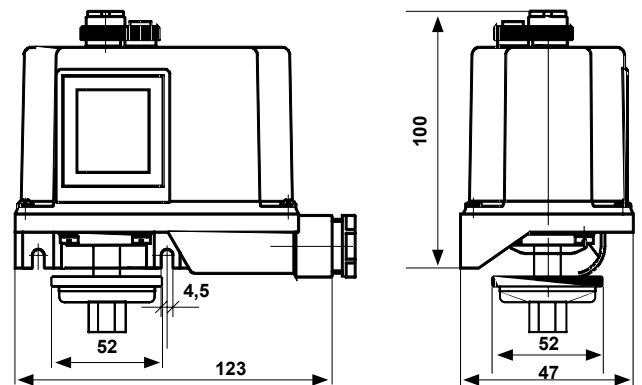

B11ANY	0,15 ÷ 1	0,1 fixed	20	flange	IP40	in stock
B11AN4Y	0,15 ÷ 1	0,1 fixed	20	flange	IP40	on request

1 Bar = 100Kpa \*The differential must be deducted from the range value.

# ELECTRICAL FEATURES

Snap action SPDT microswitch, contacts in AgCdO.

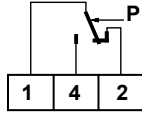

Nominal insulation tension	Ui 415V~		
Continuous duty nominal current	Ith 16A		
Operating nominal current Ie	220V~	380/415V~	
Resistive load	AC-11	-	16A
Inductive load	AC-3	-	6A
Continuous current	DC-13	0,2A	-

## EXAMPLE OF ELECTRICAL WIRING

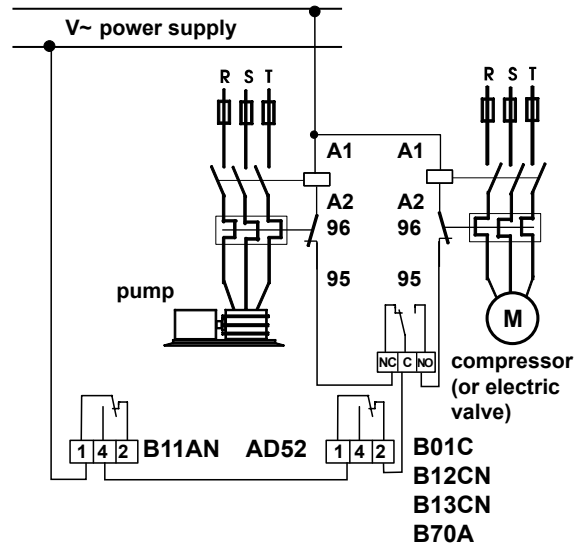

# HOMOLOGATION AND STANDARDS

Complies with EN 60947-4-1 standards.

# INSTALLATION

Direct installation on the pipe.

Pressure element connection G 1/4.

In case of fluid temperatures higher than the maximum allowed, connect the pressure switch to the pipe by inserting a metallic spiral between the pressure switch and the pipe to facilitate heat dispersion.

Possibility of mounting on metallic clamp, except for the waterproof casing versions.

## MOUNTING MODEL

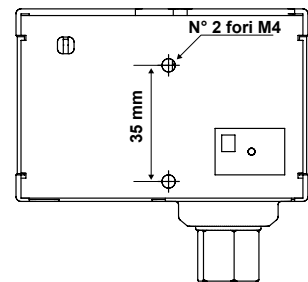

# OPERATION

When pressure increases: 1-2 opens, 1-4 closes.

# FEATURES

Elements in contact with the fluid are in stainless steel, laser welded.

Metallic frame.

Cover in shockproof thermoplastic material.

Output connections with PVC cable gland.

Connection G 1/4.

Maximum temperature of the controlled fluid: 120 °C.

Pressure switch body admissible temperature: -35 ÷ 60 °C.

Storage and transport temperature: -35 ÷ 60 °C.

Unit weight: 0,47 Kg. B11AN.