

BUTTERFLY VALVE

Series BFV ...

The butterfly valves of the series BFV are DVGW approved to the Norm EN 161 with CE product identification number. They are suitable to be used on residential and industrial combustion systems.

They are particularly suitable for both manual and automatic control of gases belonging to the first, second and third family and of air.

Installation between two flanges ISO 7005 – PN16.



TECHNICAL FEATURES

Max. pressure	: 300 mbar	Body	: aluminium
Temperature	: -10 ÷ +60°C for gas	Stem	: stainless steel AISI 303
	-10 ÷ +80°C for air	Butterfly disc	: aluminium from DN25 to DN 150
On request	+200°C for air		AISI 304 from DN200 to DN250
Control ratio	: 10:1	Stem sealing	: "O" ring in Viton
Bidirectional valves	: without zero setting		

FEATURES

- Sturdy, compact construction, especially suitable for industrial applications.
- Installation in any position.
- Mechanical position indicator.
- Lockable rotation angle from 0° to 90°.
- Without zero setting.
- External tightness by means of two "O" rings.
- Easy conversion on field from manual to automatic servicing.
- Wide range of accessories on request:
 - manual control lever
 - 1 or 2 internal reductions with respect to the nominal diameter of the valve
 - Butterfly disc AISI 304 for air temperature up to 200° C.

FLOW DIAGRAM

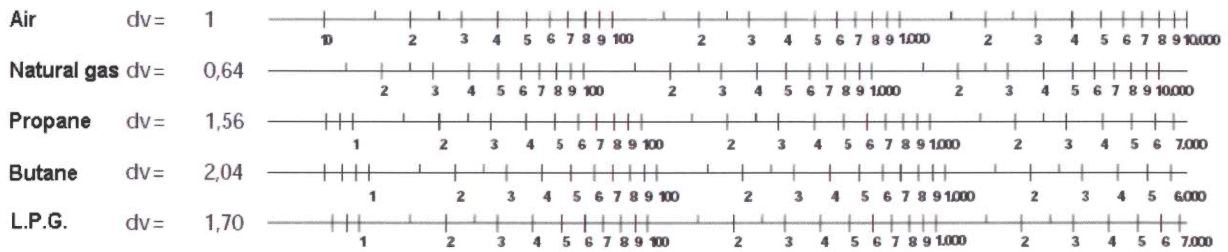
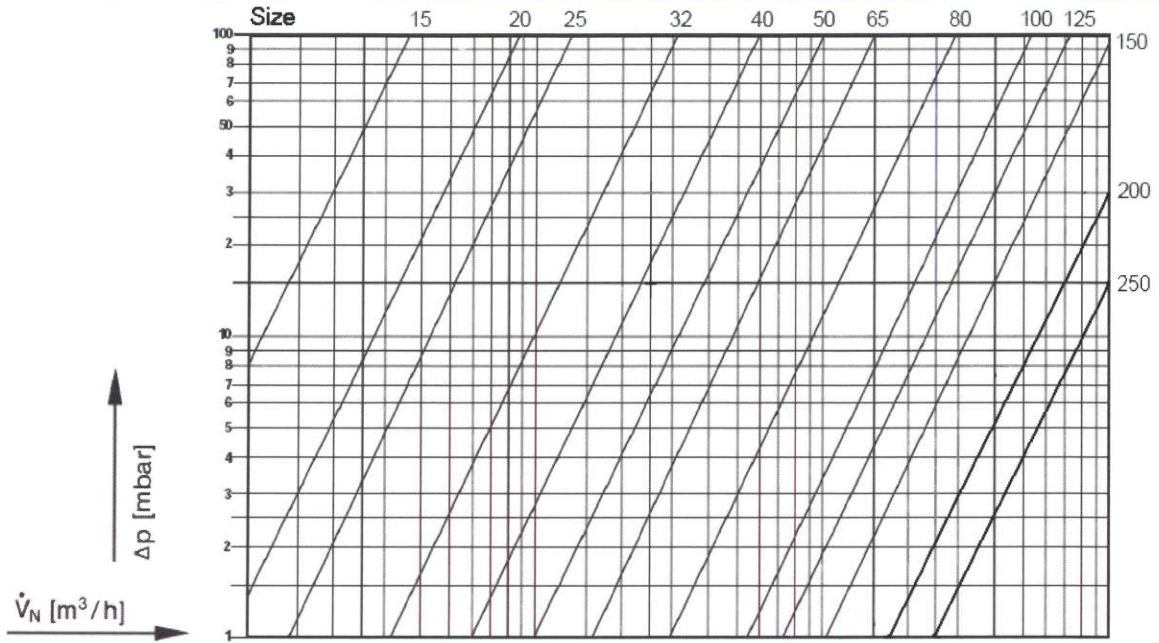

MODELS

DN	Orifice diameter [mm]	MODEL		DN	Orifice diameter [mm]	MODEL	
		Manual control	Free shaft			Manual control	Free shaft
25	20	BFV25/20.A	BFV25/20.B	80	50	BFV80/50.A	BFV80/50.B
	25	BFV25.A	BFV25.B		65	BFV80/65.A	BFV80/65.B
32	20	BFV32/20.A	BFV32/20.B	100	80	BFV100/80.A	BFV100/80.B
	25	BFV32/25.A	BFV32/25.B		100	BFV100.A	BFV100.B
	32	BFV32.A	BFV32.B				
40	25	BFV40/25.A	BFV40/25.B	125	80	BFV125/80.A	BFV125/80.B
	32	BFV40/32.A	BFV40/32.B		100	BFV125/100.A	BFV125/100.B
	40	BFV40.A	BFV40.B		125	BFV125.A	BFV125.B
50	32	BFV50/32.A	BFV50/32.B	150	100	BFV150/100.A	BFV150/100.B
	40	BFV50/40.A	BFV50/40.B		125	BFV150/125.A	BFV150/125.B
	50	BFV50.A	BFV50.B		150	BFV150.A	BFV150.B
65	40	BFV65/40.A	BFV65/40.B	200	125	BFV200/125.A	BFV200/125.B
	50	BFV65/50.A	BFV65/50.B		150	BFV200/150.A	BFV200/150.B
	65	BFV65.A	BFV65.B		200	BFV200.A	BFV200.B
				250	250	BFV250.A	BFV250.B

NOTE For max. temperature of 110 °C add "1" to letters "A" o "B".
 For max. temperature of 200 °C add "2" to letters "A" o "B".

DIMENSIONS

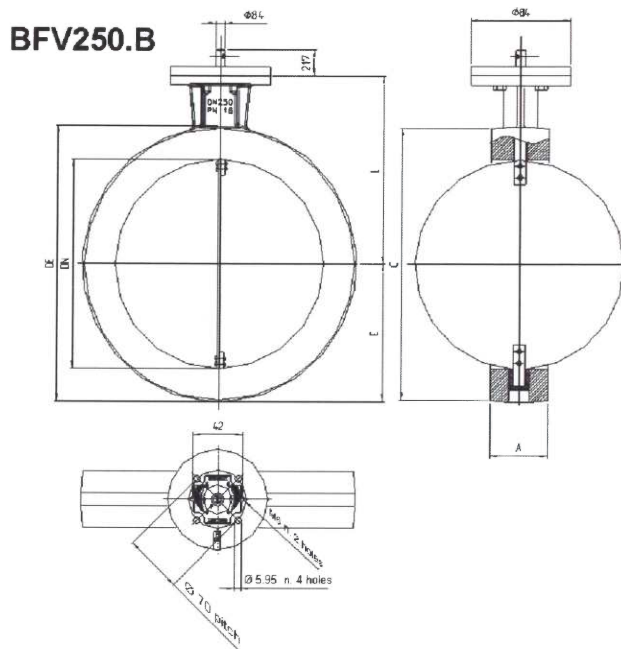
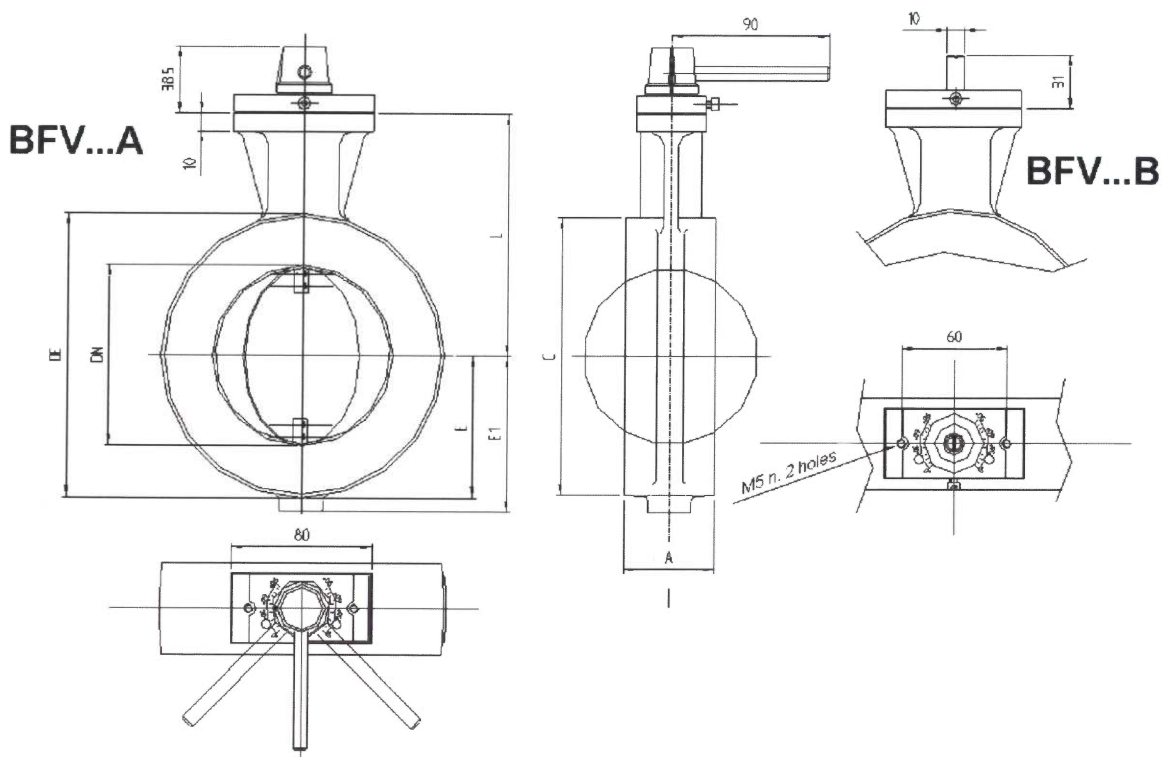

DN	25	32	40	50	65	80	100	125	150	200	250
DE	71	82	92	107	126	141	162	192	217	272	330
A	40	40	40	43	46	46	52	56	56	60	68
C	68	78	88	102	122	138	158	188	212	268	326
E	35,5	41	46	54	/	/	/	/	/	/	165
E1	/	/	/	/	1,7	1,9	2,3	2,4	2,8	3,5	/
L	81,5	85	89,5	100,5	108	128	138	149,5	162	187	225
Weight kg	0,7	0,8	0,9	1,2	1,7	1,9	2,3	2,4	2,8	3,5	8,7

1. WARNING

Installation, adjustment and maintenance of the valve must be carried out exclusively by skilled and authorized service technicians.

Non-proper installation, adjustment, changes, use and maintenance may cause damages to the personnel or to the equipment. Consequently, it is necessary to respect strictly the following instructions and local prescriptions for both the installation of electric devices, in case of motorized valves, and of gas systems.

2. INSTALLATION

- 2.1** Make sure that all operating data indicated on the valve plates correspond to those of the system.
- 2.2** When installing the valve be sure that there is sufficient clearance above the gear cover and that it can be easily accessible in order to perform manual servicing, automatic servicing by means of a gear motor or servicing by means of levers.
- 2.3** The installation of the BFV valves can be performed in any position but the position with horizontal axis is recommendable.
- 2.4** The valve can be installed in any location except where acid fumes or other deteriorating vapour may attack its metal parts or where gas leaks or explosive vapours are present in the atmosphere.
- 2.5** Do not use the valve as a lever.

3. OPERATING

- 3.1** Before operating the following points must be checked carefully:
 - tightness of the external gas pipes;
 - that valve adjustment is performed within the requested angle range;
 - that mechanical locks or other retainers, which may damage the valve, have been removed.
- 3.2** Once these preliminary checks have been performed, the main gas tap can be opened and the operation test can be carried out.

4. MAINTENANCE AND CHECKS

- 4.1** The BFV valves do not require any particular current maintenance because they do not need lubrication.
- 4.2** It is recommendable to check at least once a year that the mechanical connections have not been modified, especially in case of systems, which do not function vibration-free.

5. REPLACEMENT

In case replacement of the BFV valve is necessary, proceed as follows:

- 5.1** Close the main gas tap.
- 5.2** Remove the mechanical connections from the valve axis.
- 5.3** Remove the valve body from the inlet and outlet flanges by loosening the fastening screws from the respective nuts.
- 5.4** Install the new valve proceeding as per instructions reported in the foregoing chapters.

All the reported data are subject to be changed without notice.

Form 110502