

EUROMAX 120 FLUSH

***Professional mobile unit for washing and loading
large thermal and solar systems***

Instructions for use and maintenance



Dimensional quotes and overall dimensions

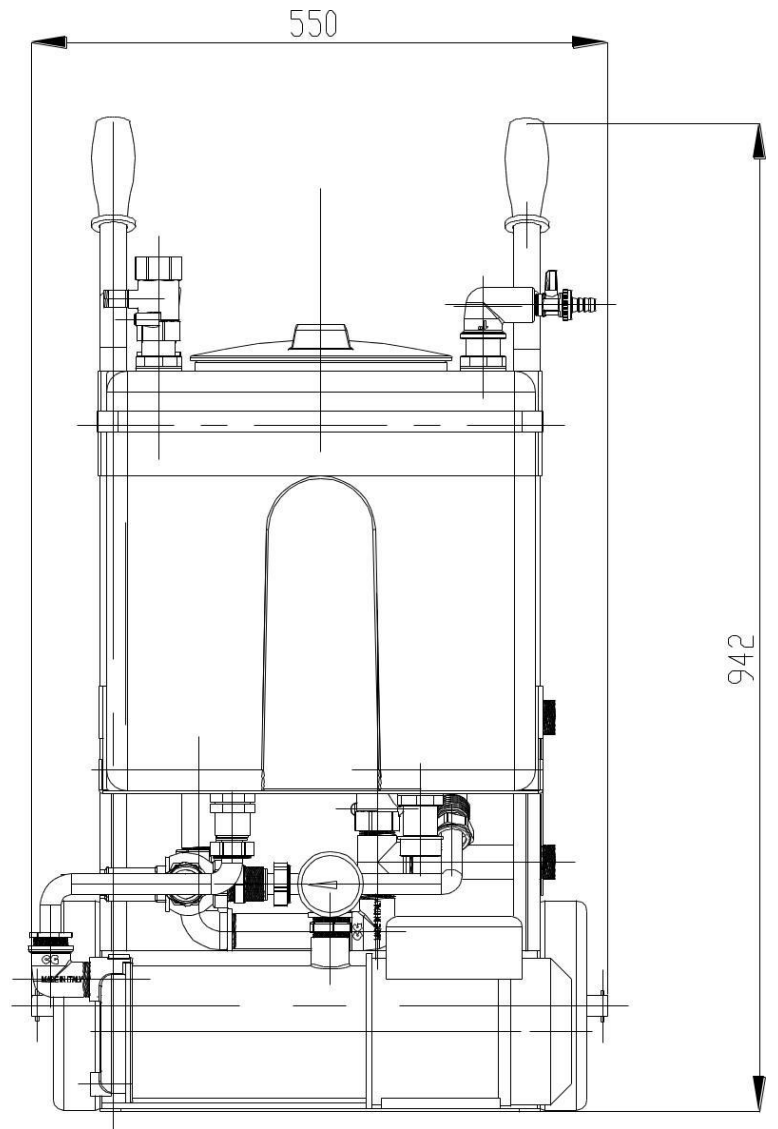
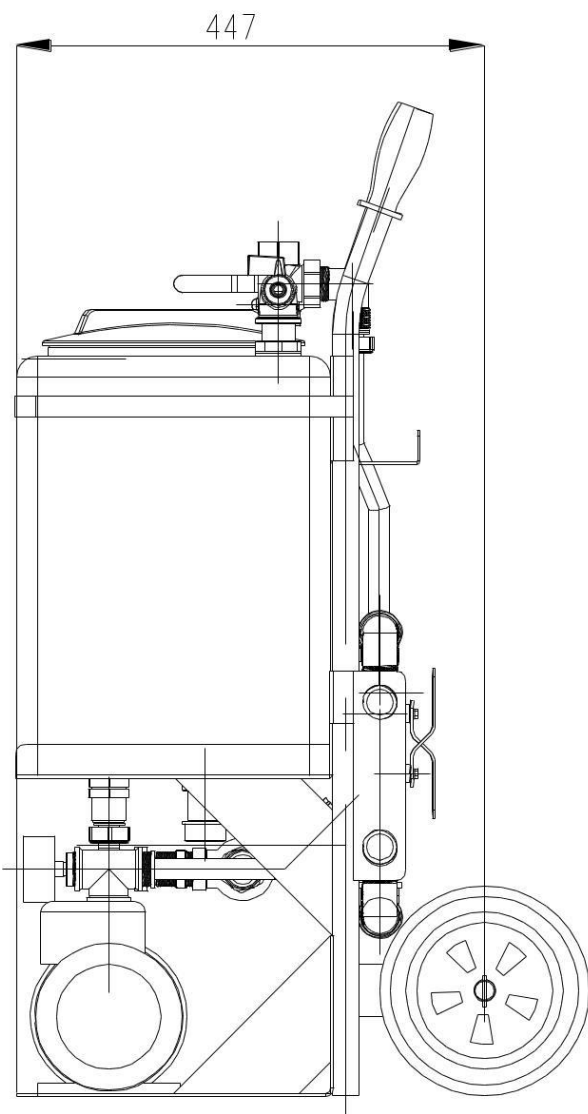

Mechanical and hydraulic descriptions

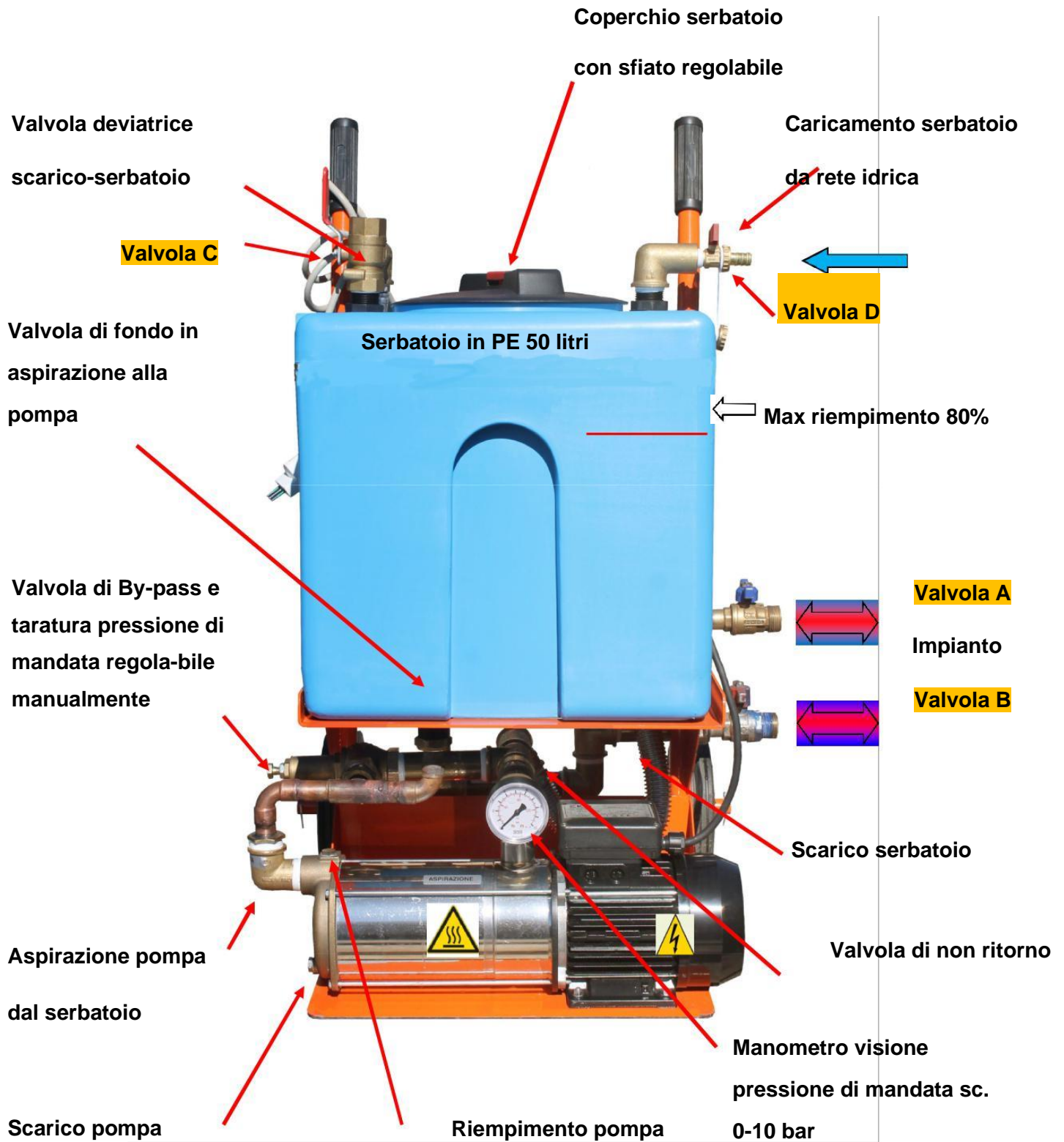

Descrizioni meccaniche ed idrauliche apparecchiatura

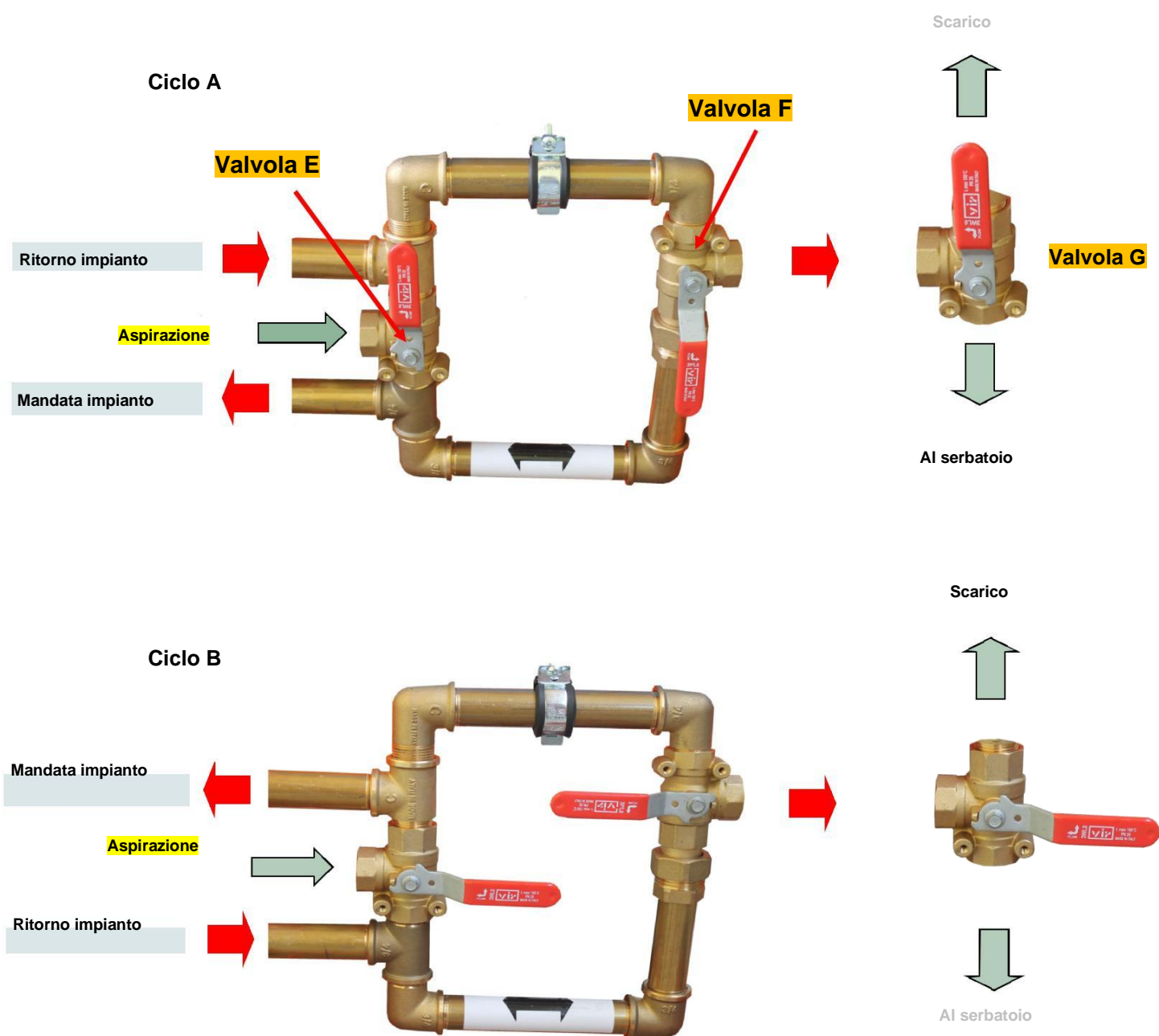

The equipment is equipped with a manual hydraulic system that allows the flow and return of the system circuit, with the possibility of reversing the water flow, therefore the reverse recirculation of the service fluid, furthermore, using valve A it is possible to load the system directly from the water network.

Instructions for flushing systems

Example of flushing a heating system. procedures:

Connect VALVES A and B to the system, making sure that all connections are well tightened and that there are no leaks. The fluid cycle is determined and identified by positioning valves E and F as shown on page 5.

Fill the tank with clean water using valve D to 80% of the tank's maximum capacity. Once the tank is filled, turn on the pump using the pump on switch; at this point, the water in the system will begin to recirculate.

The water returning from the system once it has reached valve G and based on its degree of cleanliness, you can decide whether to convey it to the tank or to the drain. Always keeping in mind that the mains supply must always be powered for any replenishment in the tank of water sent to the drain.

Once the degree of cleanliness of the return water has been checked and deemed good, add the products needed to treat the system itself to the tank.

Once the system has been treated for the necessary time using valves E and F, the direction of the flow can be reversed to make the washing process more effective.

To fill and pressurize the system, you can proceed as follows:

- Determine the delivery to the system using valves E and F (valve F must be closed in the direction of the return flow), turn on the pump and pressurize the system, checking the required pressure using the pressure gauge installed on the delivery line from the pump. The adjustable by-pass valve can be adjusted to the required pressure by unscrewing or screwing the adjustment screw 7 of the valve itself, with the measurement of the adjusted pressure highlighted by the pressure gauge.

You can proceed with the internal cleaning and restoration operations of the heating system by following, (in accordance with the state of the system and its hydraulic structure), the following operations:

Before starting any type of intervention on a panel heating system, some operations, checks and technical-constructive assessments of the system itself are necessary and recommended.

Identify the "weak" points of the system, such as flexible connection pipes, valves with obvious corrosion.

If possible, consult the design of the floor and vertical distribution network of the system

Check for any defects due to prolonged use of the heating system

Check the anchoring of all pipes to avoid any possible shaking during the operation

Possibly arrange the machine connections downstream of the distribution manifold especially if there are electrothermal heads

Exclude all by-pass, water hammer or overpressure devices present

Secure the exhaust pipe in a safe way so that shaking does not damage it.

Check the state of complete opening of the valves and plug any air vents at high points

Possibly by-pass equipment subject to breakage or misalignment such as mixers, meters, etc. etc.

Washing and sanitizing SANITARY HOT WATER storage boilers

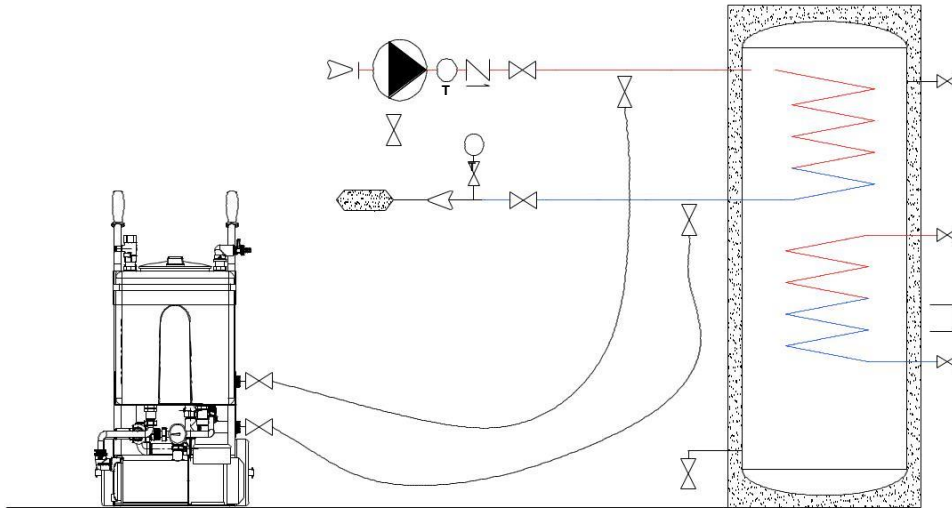

ST
T

Washing and sanitizing single radiator and radiant panel systems

