

COR35114

This is a precision tool that flares and burnishes soft copper, aluminum or brass tubing. This tool is not designed for use with steel or stainless steel tubing.

The tool has a unique, adjustable tube holding mechanism which permits flaring any size tubing within the ranges of 3/16" - 5/8" O.D. (4, 7-16mm O.D.)

To flare tubing:

1. Before flaring, be sure that tubing is cut off squarely, and remove the cut-off burrs.
2. Slip the flare nut onto the tubing.
3. Insert tubing into the adjustable opening of the tube holding assembly. Position the end of the tubing approximately 1/8" above the top surface of the holder. Cover plates of the holder are 1/8" thick and can be used as a comparison gauge for positioning tubing (See Fig. 1)
4. Tighten the clamp screw approximately 1/2 to 3/4 of a turn beyond free travel position to secure tubing. (See Fig. 2)
5. Be certain that the flaring cone surface is oiled. Slip yoke over the tube holding assembly, centering on tubing. Twist the yoke clockwise to lock it into position. (See Fig. 3)
6. Turn the yoke assembly handle, advancing the flaring cone until contact with the tubing is made. To complete the flare, turn the yoke handle the number of half-turns indicated below. For tube sizes not shown, use the next closest size or determine correct number of half-turns by trial.

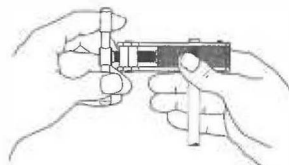

Fig. 1

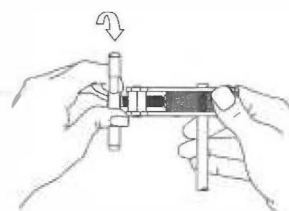

Fig. 2

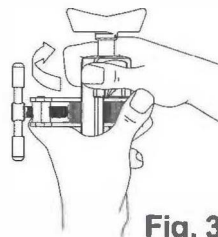
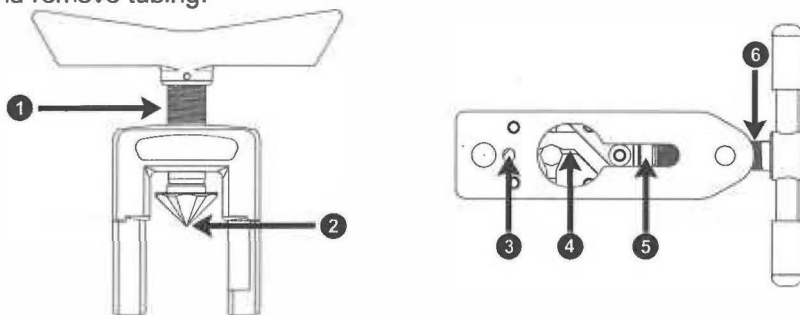

Fig. 3

TUBE SIZE O.D. (INCHES)	NUMBER OF HALF-TURNS
3/16	4
1/4	4
5/16	5
3/8	5
1/2	6
5/8	6

7. After flaring, back off the flaring cone to remove the yoke, loosen the clamp screw and remove tubing.



Suggestions for keeping your Grabber™ Rol-Air™ flaring tool in good operating condition:

Keep tool clean and frequently lubricate moving parts (numbers 1, 3, 4, 5 and 6). Maintain a light film of oil on the flaring cone surface (number 2).

If the tube holding assembly becomes dirty, turn the clamp screw to full open position, and immerse assembly in solvent. After drying, lubricate as indicated above.

If you want to store this tool with the yoke engaged on the tube holding assembly, place the point of the flaring cone so that it rests in cover plate hole 3.

Never tighten the flaring cone against the laminated blocks, as damage to the tool may result.