



HVAC/R TOOLS AND
VACUUM PUMPS SPECIALIST

CORDLESS FLARING TOOL

INSTRUCTION



WK-E800AM-L



— Contents —

Safety Precautions	1
Names of Parts/Standard Specifications/Standard Accessories	5
Operating Instructions	7
Regular Maintenance and Inspection	11
Before Asking for Repairs or Servicing	12
Special Accessories	13

Safety Precautions

Thanks for purchasing **DSZH**[®] products. for safe and correct using, please read this user instruction carefully before using the product.



WARNING

- 1) Ensure you use the correct voltage.**
 - Be sure to use the voltage indicated on the name plate of the main unit or in the instruction manual. If the voltage is different from the voltage indicated overheating smoke or fire may occur.
- 2) Check the switch is OFF, before inserting the plug into the power supply socket.**
 - If the plug is inserted into the power supply when the switch is ON. the machine may start operation abruptly, and is liable to cause accidents. Be sure to check the switch is OFF.
- 3) Be sure to avoid electric shock.**
 - Do not touch the plug with wet hands.
 - Do not use the machine in rain or in places where water can easily get into the machine.
 - Be sure to ground the machine to avoid electric shock.
- 4) Take notice of conditions at the work site.**
 - Do not use the machine in rain, humid or damp places, or places where water can easily get into the machine. Humidity will lower insulation of the motor and cause electric shock.
 - Do not use close to flammable fluids or gases, such as gasoline and thinner. Fire or explosion might occur.
- 5) Use designated accessories and attachments.**
 - Do not use accessories and attachments other than those designated in the operation manual or our catalogs. Accidents or injuries might result.
- 6) In the following cases, turn the main unit OFF and pull the plug out of the power supply socket.**
 - When the machine is not in use or parts are changed, repaired, cleaned or inspected.
 - When accessories are changed.
 - When hazards are expected (including electric power failure)
When the plug is inserted, the main unit may start operation unexpectedly, causing accidents.
- 7) If any abnormality is noticed, stop operation immediately.**
 - When operation of the machine is not smooth or abnormalities such as unusual odors, vibration or noise are detected, immediately stop operation of the machine.
 - Check symptoms against the items in [Troubleshooting Methods] in the instruction manual, observe corresponding instructions. If the machine is being used continuously, overheating, smoke or fire might occur, causing accidents or injury.
 - If overheating or smoke from the main unit occurs do not attempt an overhaul but ask for an inspection and repair.
- 8) Keep the work site clean.**
 - Ensure you keep the work table and the work site in good order, and well lit.
A cluttered site and work table are liable to cause accidents.
- 9) Do not let authorised personnel come near the machine.**
 - Do not let any people other than authorised personnel touch the main unit or the power supply cord or operate the machine.
 - Do not let people other than authorised personnel enter the work site, especially children. Injuries might occur.
- 10) Do not use the machine with force.**
 - Use the machine only for its designated purpose. Operate according to the capacity of the main unit. to assure safe and effective operation. Forced operation may not only cause damage to the product but also accidents.
 - Do not use the machine in the any way that could cause the motor to lock, or cause smoke or fire.

Safety Precautions



WARNING

11) Wear neat clothing .

- Do not wear neck ties, clothes with open sleeves, loose clothing, accessories such as necklaces, etc., which could get caught in the rotating parts.
- When working outdoors, it is recommended to wear rubber gloves and shoes with stoppers. Slippery gloves and shoes are liable to cause injuries .
- Cover long hair with caps or hair nets, to prevent them getting caught in rotating part.
- Wear safety caps, safety shoes, etc. according to the working environment.

12) Do not work in an unnatural posture.

- Keep a firm footing and balance to avoid falling over and injuring yourself.

13) Remove teels such as Wrenches.

- Before turning on the switch, check that tools used for inspection and adjustment have been removed. If you use the machine when tools are left inside it, accidents and injuries may occur.

14) Operate the unit with great care.

- Always work with great attention to handling methods, workiry meihods and surrounding conditions. Carelessness may result in accidents and injuries.
- Do not operate the machine when concentration is lowered such as when tired, after drinking alcohol. when sick, affected by medicines, etc.

15) Do not handle the power supply cord carelessly.

- Do not carry the product by the cord, or pull the plug out of the socket with the cord.
- Do not place the cord near heated objects, fats & oils, cutters and objects with sharp edges.
- Take care not to tread on the cord, pull the cord or apply unnecessary force resulting in damage to the cord. Electric shock or short-circuit may occur, causing fire.

16) Perform careful maintenance daily.

- When changing accessories and parts, follow the instruction manual.
- Periodically inspect the power supply cord and plug, If damaged, ask to your sales agent or our sales branch for repairs.
- If an extension cord is used. inspect the cord periodically, and if damaged, replace it. if extension cords are used outdoors, use extension cords designed for outdoor use to prevent electric shock, short-circuit or fire.
- Keep gripping parts dry and clean and free of oil and grease, Slipping may cause injury.

17) Check for damaged parts.

- Before using the machine, carefully check for damage to the protective cover and other parts, and check both normal operation and specified functions.
- Check for any abnormalities such as in adjustment of movable parts, tightening, damage to parts, and all parts affecting operation.
- Do not use machines if the stop and start switches do not work.
- In replacing or repairing a broken protective cover and other parts, follow the instruction manual. If no instructions are specified in the instruction manual, ask your sales agent or our sales branch for repairs.

18) Store carefully when the machine is not in use.

- Store in a dry place away from children and locked with a key.

19) For overhaul and repair of the machine, ask an appointed DSZH agent.

- Our products comply with corresponding safety standards. Do not remodel.
- Be sure to ask your sales agent or our sales branch for any repairs.
If repairs are ca~ied out by unskilled or unqualified personnel, the perfonnance of the unit will be adversely affected and may result in accident or injury.

WARNING

① **Hold the tool securely.**

When the tool is switched on and the flare cone starts rotating, the hand you hold the tool with may be jarred; take care not to hit any objects around you.

② **Always use the exclusive charger.**

Always use the exclusive charger for charging. It is dangerous to charge with any other charger, so never attempt to do so. Do not try to use the charger for charging other tools or batteries, or for any other purpose.

③ **Never use boosters or other transformers for charging.**

This can damage the charger; always use with a 220V supply.

④ **Never charge with an engine generator or DC power source.**

Do not use an engine generator or DC power source for charging. The charger may be damaged.

⑤ **Always charge indoors.**

- When charging, do not let the battery or charger get wet; charge indoors.
- Do not place the charger close to an open flame.
- Keep all inflammable materials away from the charger.
- The battery or the charger may get slightly hot during charging; choose a dry and well-ventilated place that is not exposed to direct sunlight.

⑥ **Moisture can cause accidents.**

Do not try to charge or use this product in the rain or in wet or damp places. Moisture can cause electric shock, in addition to weakening the insulation of the charger or the motor. Always avoid moisture.

⑦ **Unplug the charger after charging is complete.**

Unplug the charger cord from the power source after charging is finished. If there is a power failure, always remove the charger attachment plug from the power source.

⑧ **Charge in a range of 5°C to 40°C.**

This product employs a special charging circuit for fast charging (about 1 hour); always charge within a temperature range of 5 to 40°C. Below 5°C, it may overcharge, shortening the life of the charger. Above 40°C, charging may not be possible. The most suitable range is 20 to 25°C.

⑨ **Do not charge continuously with the same charger.**

- If the same charger is used to charge many tools continuously, it could be damaged due to overheating. Once charging is finished, let the charger rest for about 15 minutes before charging again.
- Normally, at an ambient temperature of about 20°C, the tool will be fully charged in about 1 hour and the pilot lamp will then go out. However, below 20°C, the pilot lamp may stay on even after 1 hour.

Safety Precautions

WARNING

- ⑩ **Do not immediately recharge a battery that has been used up quickly .**
A battery that has been used up quickly due to continuous operation becomes abnormally hot. Therefore, when such a battery is placed in the charger, a red pilot lamp will light up, either preventing a recharge, or resulting in an insufficient charge. Always charge the battery after it has cooled.
- ⑪ **Do not charge for more than 2 hours .**
If the pilot lamp stays on even after charging for 2 hours, the product may be faulty. Stop charging and take the product to your nearest sales agent.
- ⑫ **Keep the battery mounting hole clean.**
The battery mounting hole on the charger has charging terminals. If this hole is contaminated with metal chips, water or other foreign matter, the terminals may be short-circuited, causing damage to the charger .
- ⑬ **Do not disassemble the battery of the charger.**
- The battery houses a special device designed for quick charging (in about 1 hour); never try to disassemble it or it may be damaged .
 - The charger houses condensers and electronic parts. Disassembling could result in electric shock or damage to the charger; never try to disassemble it.
- ⑭ **Never short-circuit the charger.**
- A battery with extremely low internal resistance is used. If short-circuited, there may be a surge in the current, resulting in overheating, burns or damage to the battery.
- ⑮ **Never put the battery in a fire.**
Never put the battery in a fire or an incinerator or it may explode
- ⑯ **Take care when working in high places.**
When working in high places, make sure that there is nobody below you.
- ⑰ **Keep the ventilation hole on the charger clean.**
Keep the ventilation hole on the charger clear of metal chips and inflammable materials as they may cause electric shock or damage. Avoid using the charger in dusty places.
- ⑱ **Stop charging if any abnormality is detected.**
If you detect abnormal heat or any other abnormality while charging, stop immediately and take the charger for repairs .
- ⑲ **Store the charger properly.**
Store the charger in a dry place out of the reach of children and where the temperature does not exceed 40°C . Never store under the eaves etc. where rain might get in. Deterioration of the electrical insulation can result in electric shock.

Names of Parts/Standard Specifications/Standard Accessories

Names of Parts

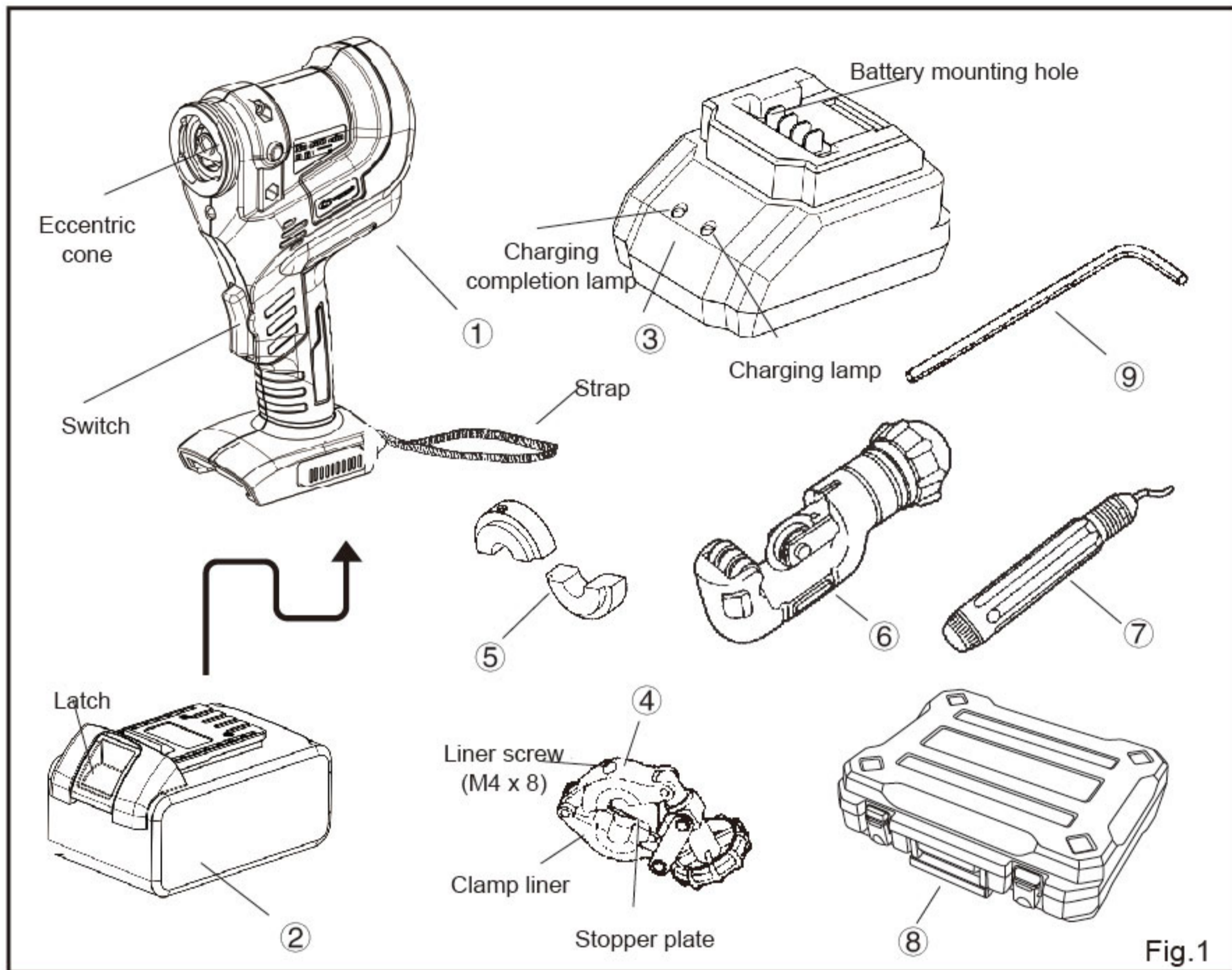

Standard Specifications

	Product name	Quantity
1	Flaring tool	1 Pcs
2	Battery	1 Pcs
3	Charger	1 Pcs
4	Clamp	2 Pcs
5	Liner	7 Pcs
6	tube cutter	1 Pcs
7	Scraper	1 Pcs
8	Carrying case	1 Pcs
9	Allen wrench	1 Pcs

Table 1

Names of Parts/Standard Specifications/Standard Accessories

■ Standard Specifications

(1) Flaring tool

Applicable pipe	Copper tube (O/OL material)						
Applicable pipe size	Outer diameter	1/4"	5/16"	3/8"	1/2"	5/8"	3/4"
	Outer diameter	6mm	8mm	10mm	12mm	16mm	19mm
	*(Clamp liners for 5/8 and 3/4 diameter tubes sold separately.)						
Flaring shape	Complies with shapes described in JIS B 8607.(To be referred to separately.)						
Processing method	Eccentric cone (constant-pressure plunge rotation)						
Cone speed (rpm)	280rpm						
Power	DC motor						
Battery potential for flaring	Approximately 700 tube ends per fully charged battery. (May vary depending on usage.)						
Processing time	Approximately 5 seconds.						

Table 2

(2) Battery

Battery type	Lithium Battery
Voltage	18V
Capacity	4000mAh
Charging time	Approximately 60 minutes
Battery rechargeability	Up to 500 times
Charging temperature	5 ~ 40°C

Table 3

(3) Charger

Applicable battery	Lithium Battery 18V
Power supply	AC 220 ~ 240V (50/60 Hz)
Charging mode	Temperature control
Charging voltage	18V
Charging current	2400 mA
Operating temperature	5 ~ 40°C

Table 4

Preparations before use

(1) Charging the battery

- ① Remove the battery from the main unit by pressing the latch on the battery. (Fig. 2)
 - Hold the main unit firmly and remove the battery.
 - When the flaring tool loses power, recharge the battery. If the battery is completely drained, it may not be possible to fully-recharge it, resulting in shortened battery life.

- ② Attach the battery to the battery mounting hole of the charger. Be sure to insert the battery fully into the hole. (Fig. 3)
 - Make sure the battery is aligned correctly.
 - Charge the battery within a temperature range of 5 to 40°C. Charging the battery outside this range may cause the battery to leak or become abnormally hot. In addition, the performance and the life of the battery may be adversely affected.

- ③ Plug the charger into the power source. The red charging lamp comes on, and charging starts. When the charge completion green lamp comes on, charging is complete. It takes about 60 minutes to complete charging. (Fig. 4)
 - The input voltage for this charger is AC220V(50/60Hz).
 - If you intend to charge another battery, leave the charger to cool for at least 15 minutes before charging the next one.
 - When the temperature of the battery is too high, recharging is not possible. (The green charge completion lamp will come on erroneously when a battery that is too hot is placed on the charger.)

- ④ Remove the battery from the charger, and then attach it to the main unit. (Fig. 5)
 - If the battery cannot be fully recharged even after following the correct procedure, the battery life may have run out. Charging the same battery as is may damage the charger.

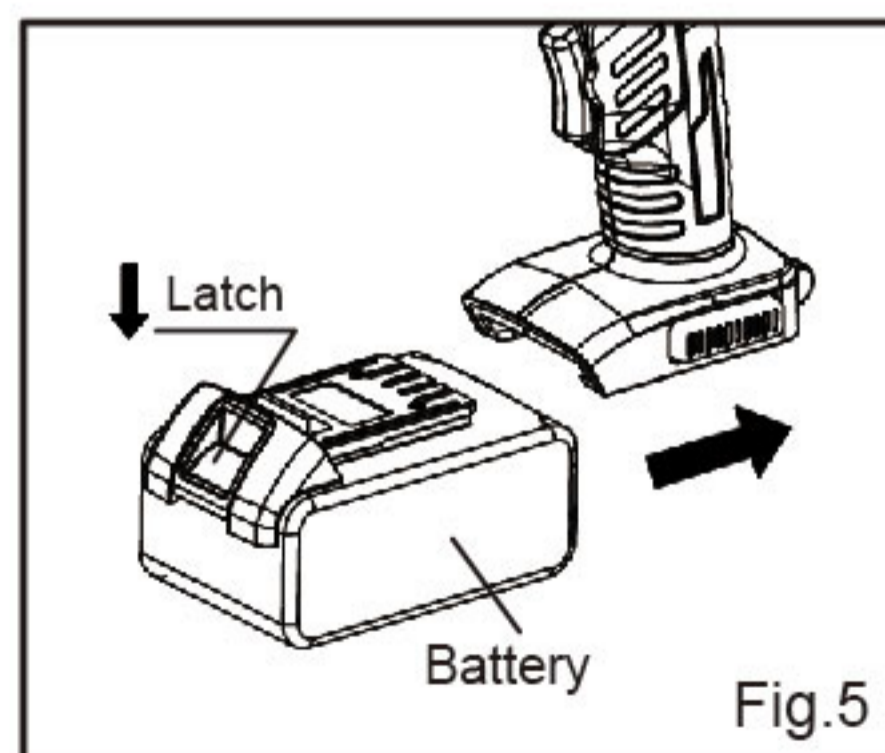
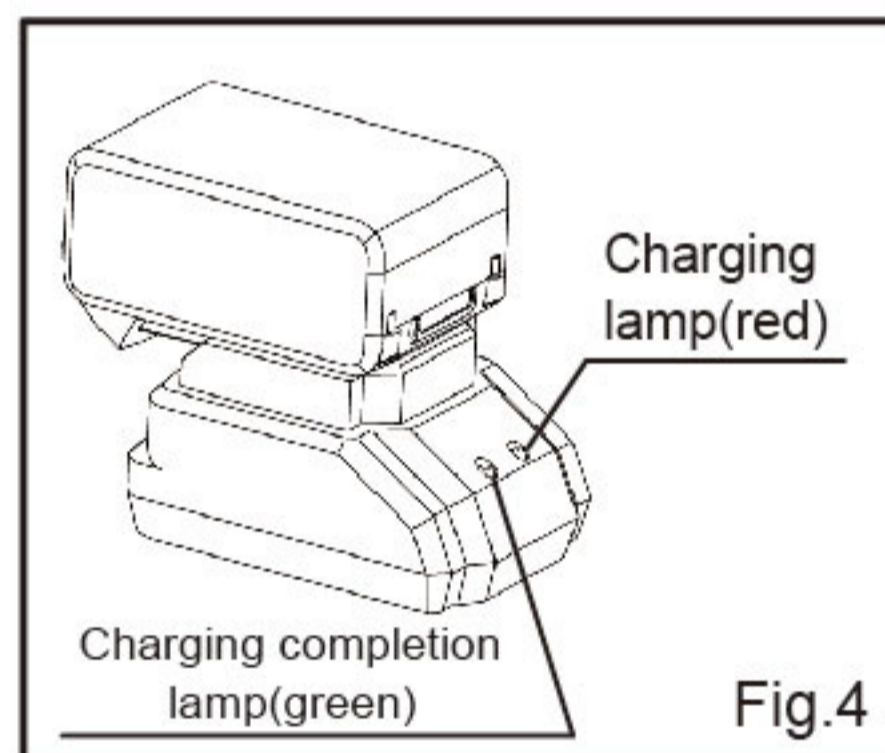
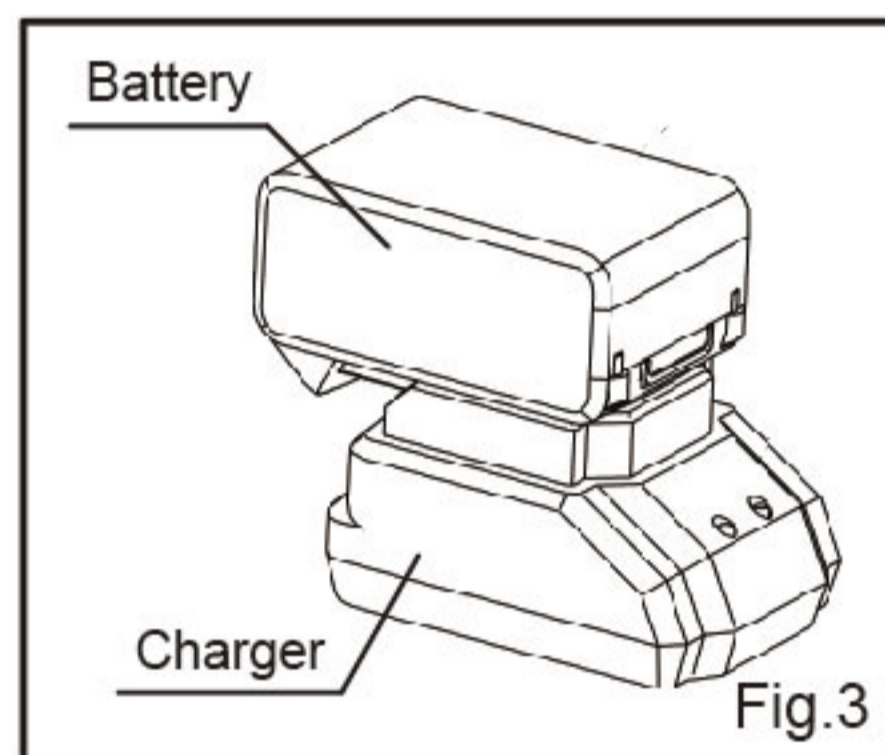
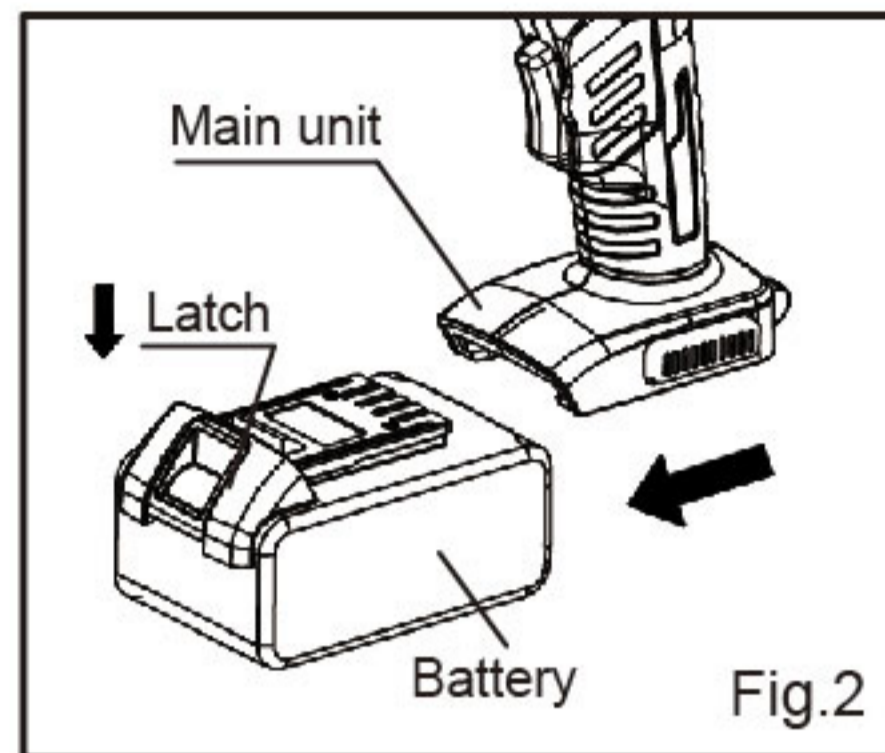

Operating Instructions

(2) Cutting and scraping the tube

- ① Mark a line where you wish to cut the tube, and then place the tube on the cutter. (Fig. 6)
 - Tighten the cutter so that the blade lightly presses against the tube.

- ② Rotate the cutter around the tube in the direction of the arrow (Fig. 6) while feeding the blade by turning the knob little by little.
 - When feeding the cutter blade, the knob should be turned at a rate of approximately one eighth of a rotation per one to three rotations of the tube cutter.
 - If you feed the blade too quickly, the tube may be deformed and the tube cannot be flared properly. (Fig. 7)
 - When you use a tube without first cutting it, check that the tube is not deformed. (Fig. 7)

- ③ Remove burrs from the cut end of the tube with a scraper. (Fig. 8)
 - Hold the cut end facing downward so that metal chips do not fall into the tube.
 - If the cut end has not been properly scraped, the tube cannot be flared properly, and a gas leak may result.
 - Do not make any scratches on the inner surface of the tube to be flared. Damage or scratches may remain even after the tube is flared.

Making a flare

(1) Clamping the tube

- ① Slide a flare nut that is compatible with the tube size over the tube. (Fig. 9)
 - Be careful of the orientation of the nut.
 - Confirm that there are no burrs left on/in the copper tube.Note that if any burrs remain, the surfaces that are flared may become dented and cause a gas leak.

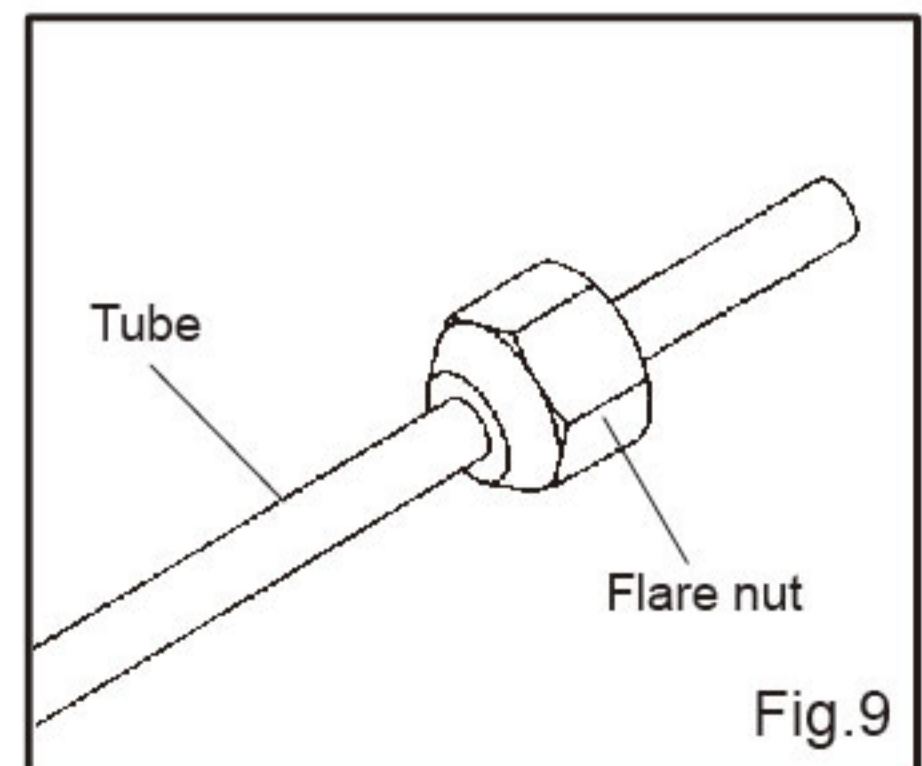
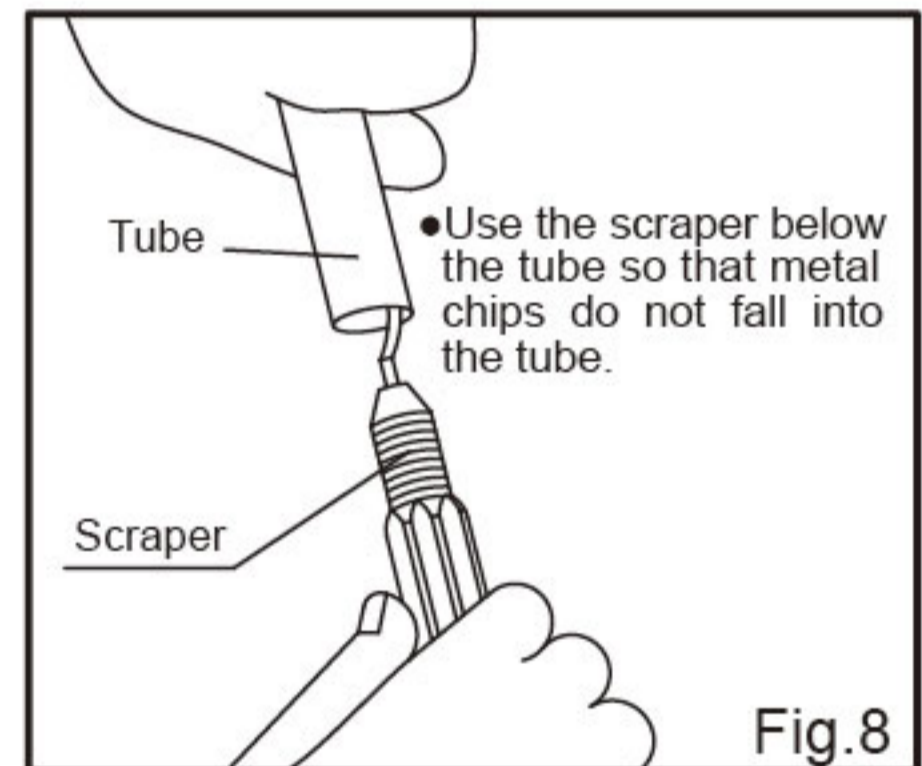
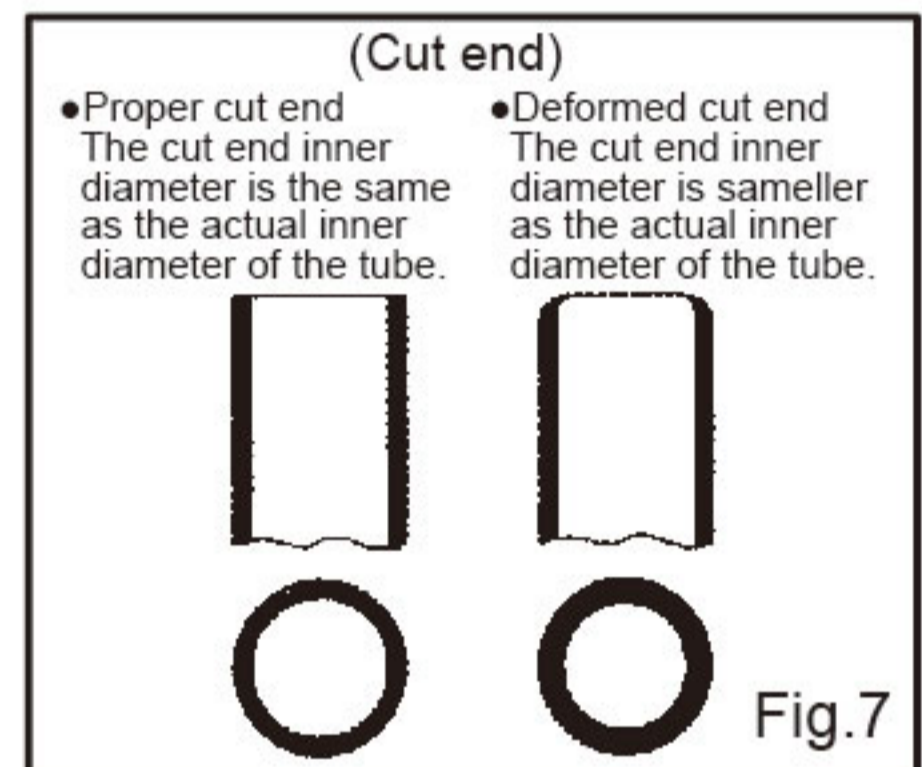
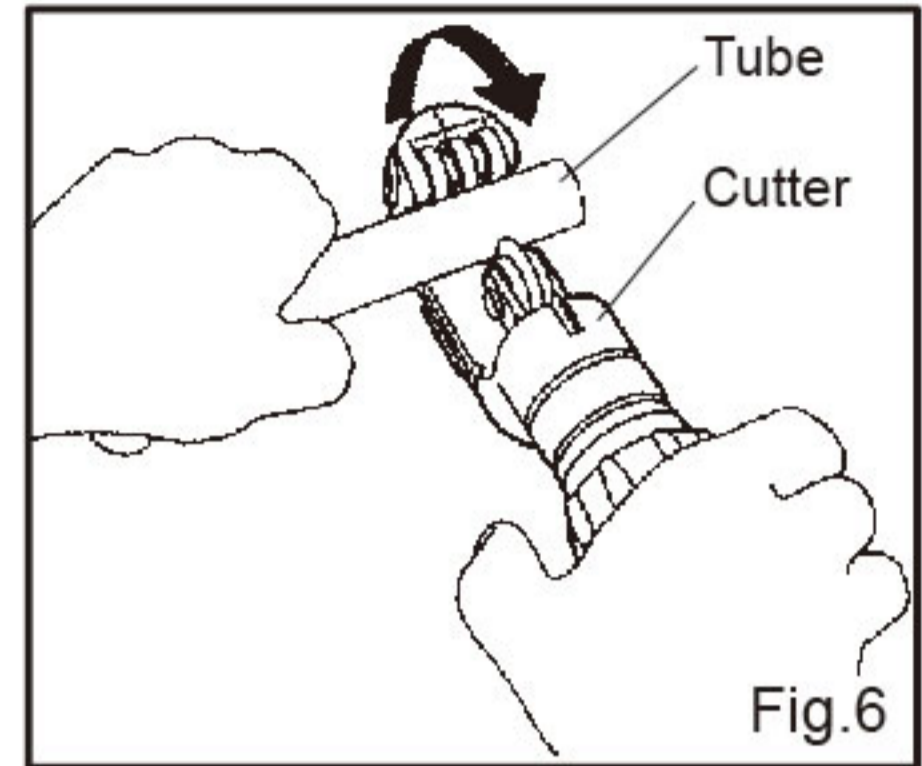

Operating Instructions

- ② Choose a clamp that is compatible with the tube size, and then place the tube so that the tube end contacts the stopper plate. (Fig. 10)

- * If there is a space between the tube and the stopper plate, the resulting flaring diameter will become smaller.
- * By turning the knob immediately be opened or arrow, the clamp can immediately be opened or closed.
- * Remove any metal chips from the liner, the flare cone and the tube.

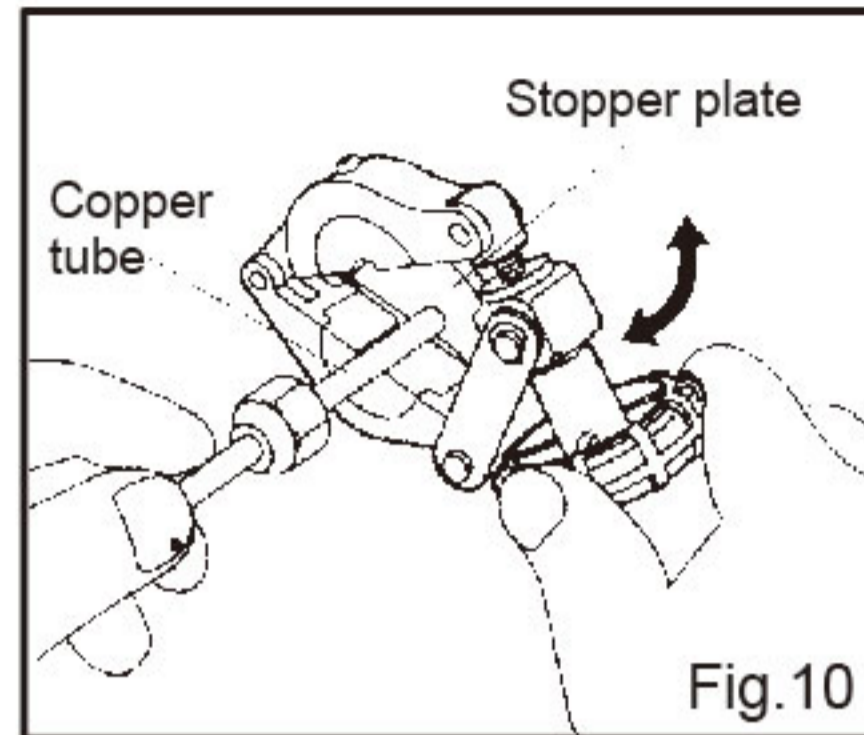

- ③ When the liner is replaced to change sizes, be sure to fit the new liner properly in the clamp before securing it with the socket bolt. (Fig. 11)

- * Secure the clamp to the liner using the hexagonal bar spanner provided (opposita side: 2.5mm) and hexagonal socket bolt (M4x8).

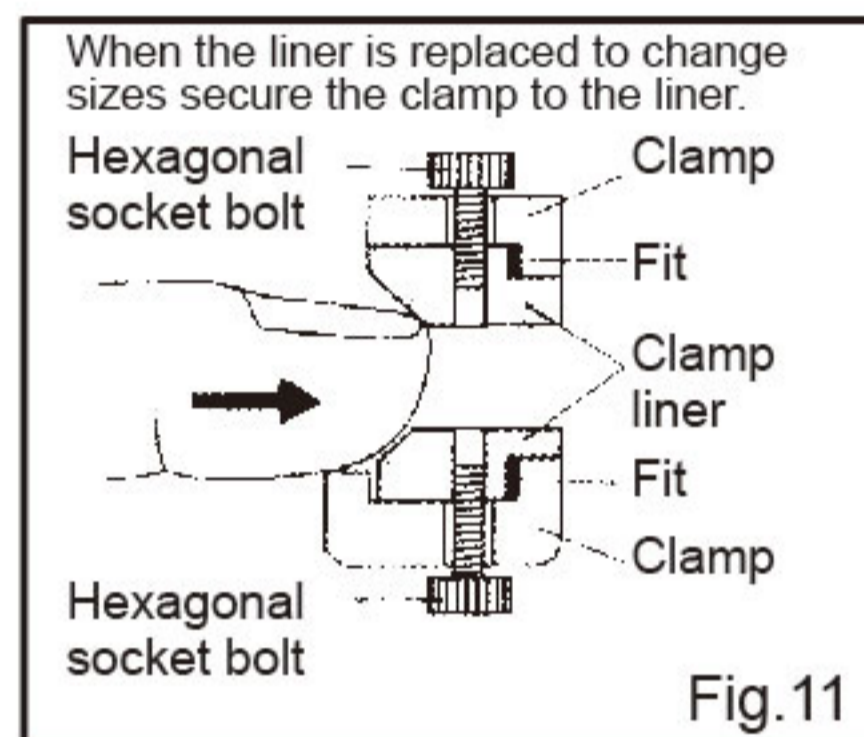

- ④ Check that the tube is placed correctly, and then clamp the tube. (Fig. 12)

- * To confirm that the stopper plate is in perfect contact with the tube, try to raise the stopper plate slightly with your finger. If the stopper plate is easy to shift, it implies that there is a space between the stopper plate and the tube, so reset the tube.
- * Turn the clamp knob until the clamps are closed firmly.
- * The distance between the liners is set slightly shorter than the external diameter of the tube so that the tube will not become loose or slip. Therefore, when clamping the tube, the exterior of the tube will be scratched, but this will not pose any problem.

- * When the knob is hard to turn, apply oil or grease to the points shown on the right. (Fig. 13)

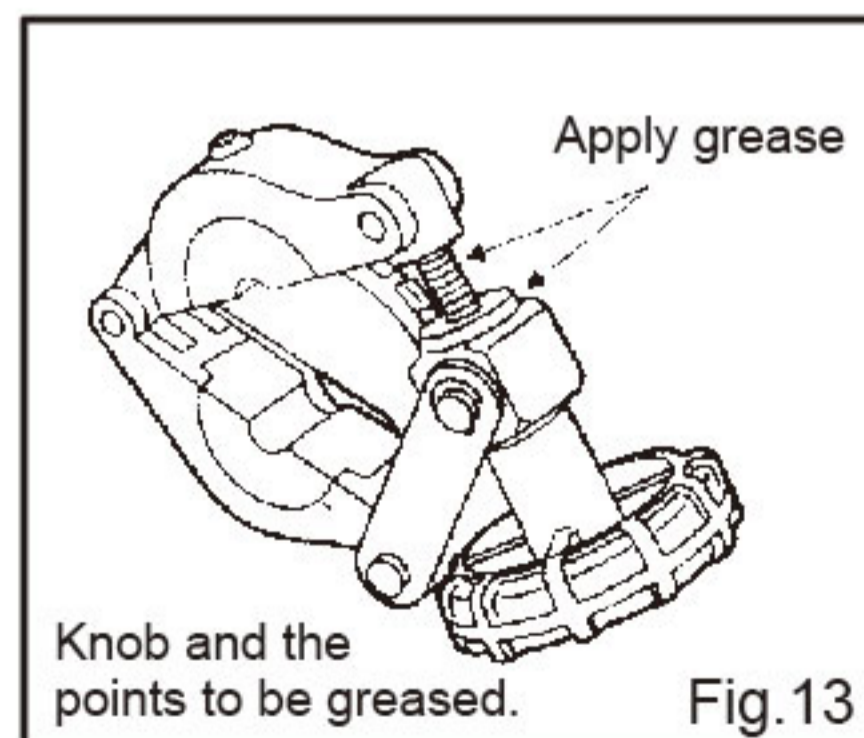
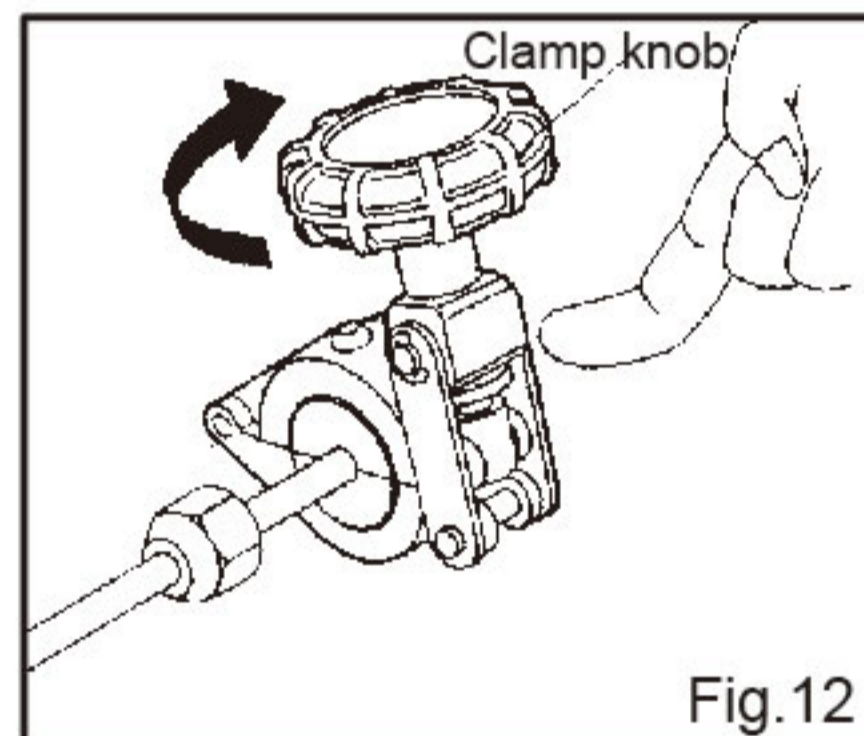

Operating Instructions

(2) Flaring

- ① Attach the clamp (in which the tube has been placed) to the main unit. (Fig.14)
 - * Attach the clamp to the main unit by aligning the joints on the clamp with the recesses in the main unit, and then turn the main unit in the direction of the arrow until you hear a click. (Fig.15)
 - * The clamp can be set on the main unit only when the flare cone (on the main unit) is fully-retracted. If the flare cone is sticking out, press the lower part of the switch to put it in the retracted position. When you hear a clank (from the clutch), implying that the flare cone is fully-retracted, return the switch to its original position, (Fig.16)
 - * Remove any foreign matter (metal chips, etc.) from the flare cone, Not removing the foreign matter could cause scratches on the inner surface of the flare, or a gas leak.
- ② Start flaring by pressing and holding the upper part of the switch. Flaring will be completed within 3 seconds from when you hear a clank (from the clutch). Release the switch to stop the rotation. (Fig. 16)
 - * If the time for idling (from when the clutch starts operating until you release the switch) is short, it may sometimes result in insufficient flaring.
- ③ Press and hold down the lower part of the switch. The flare cone will be retracted while rotating in reverse. When the flare cone is fully retracted, you will hear a clank. Return the switch to its original position. (Fig. 16)
 - * When the battery is on the verge of running out, flaring will exhaust the power for reverse rotation, thus preventing the flare cone from returning to its retracted position. Therefore, be sure to recharge the battery before it becomes weak.

(3) Removing the tube

- ① Detach the clamp from the main unit by reversing the installation steps. (Fig.17)
 - * The clamp cannot be removed unless the flare cone is fully retracted. Avoid removing it forcibly, otherwise the flaring tool may be damaged.

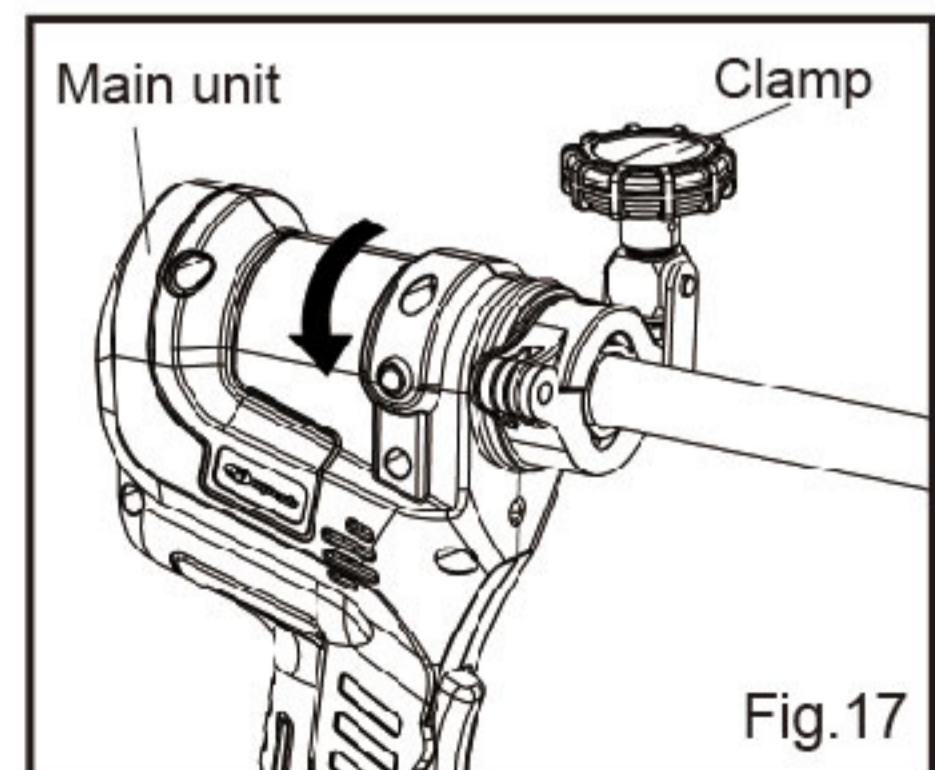
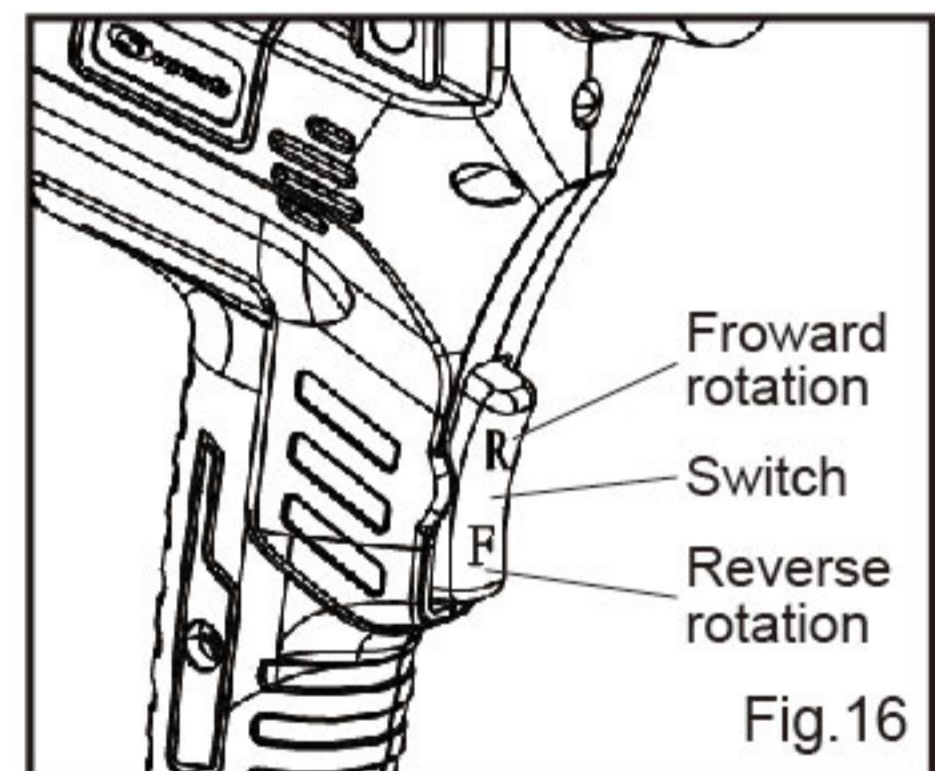
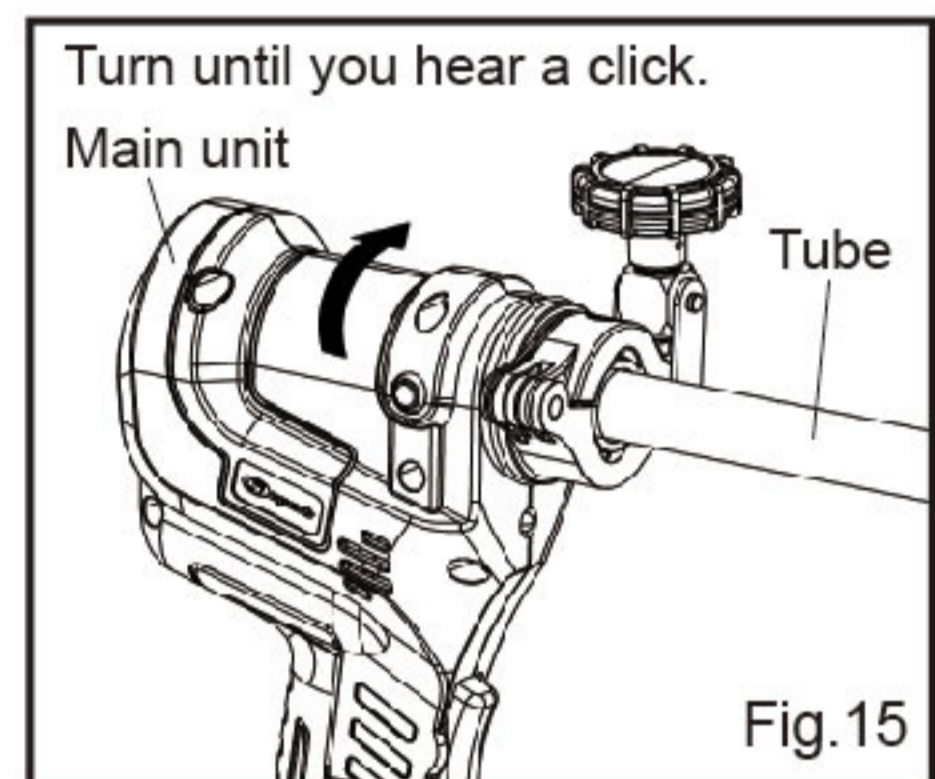
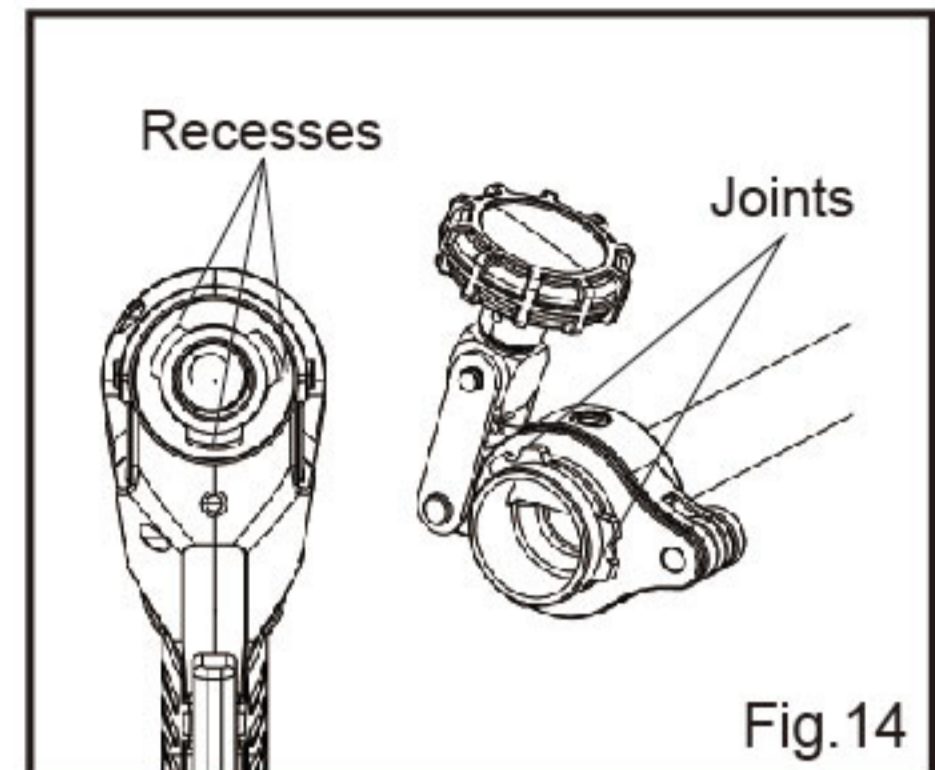

Regular Maintenance and Inspection

② Loosen the knob to open the clamp, and then remove the tube.(Fig.18)

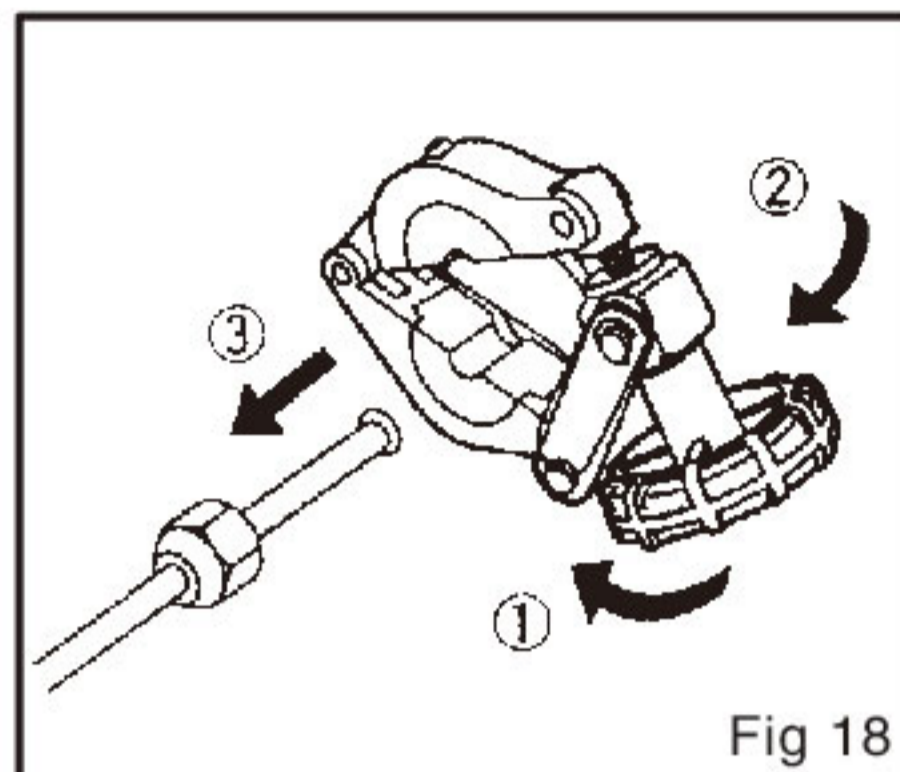

CAUTION

- Before inspection or maintenance, be sure to turn OFF the switch and also remove the battery from the flaring tool. If the battery is not removed, the tool may activate unexpectedly, causing serious injury.
- When an abnormality is found during inspection or maintenance, identify the problem referring to the descriptions in “Before asking for repairs or services” and then follow the relevant instructions. Using the product as is (without correcting the abnormality) may generate heat, fumes, or fire, causing serious accidents or injury.

1. Check all screws

Check all screws for looseness on a regular basis and tighten any that are loose. Using the product if any screws are loose can be dangerous.

2. Keep the surface clean

Clean the outside of the charger with a dry, soft cloth or with a cloth dampened in soapy water. Do not use chlorine-based solvents, gasoline or paint thinner as they may dissolve the plastic.

3. Store properly after work

After the job is finished, store the product in a dry place where the temperature does not exceed 40°C and with the battery separated from the charger. Keep out of the reach of children.

Requesting repairs

This machine is produced with great precision; therefore, should the machine fail to operate normally, do not repair it by yourself, but call us for repairs. If parts are required or if you have any questions, please contact us at your earliest convenience.

Before Asking for Repairs or Servicing

If an abnormality occurs with the product, check the following and then contact the manufacturer or the sales agent from whom you purchased the product.



CAUTION

If there are no descriptions (including instructions) regarding the problem in question in the following troubleshooting table, never try to disassemble or repair the product by yourself.

If any problems are not dealt with below or if there is any instruction that indicates repair or servicing, be sure to contact the manufacturer or the sales agent from whom you purchased the product.

If the product is repaired by personnel without the proper knowledge or skills to repair this product, it may cause serious accidents or injury, as well as adversely affecting the performance of the product.

■ Troubleshooting

Problem	Possible causes	Corrective measures
The flaring diameter is too small.	The tube end was pinched due to feeding the blade too quickly when the tube was cut,	Feed the cutter blade slowly to cut the tube. (Refer to page 8.)
	Burrs were left on the tube end.	Remove the burrs. (Refer to page 8.)
	There was a space between the tube end and the stopper plate.	Place the tube taking care not to leave a space between the tube end and the stopper plate. (Refer to page 9.)
	The idling time from when the clutch started operating was too short	Make the idling time longer. (Refer to page 10.)
	Flaring pressure is diminished.	Ask for inspection or repairs. (Refer to page 12.)
Ring-shaped flaws occur on the flared inner surface of the tube. (If the flaws are shallow, this does not pose a problem.)	A large burr was on the pipe end. Remove the burrs. (Refer to page 8.)	Remove the burrs. (Refer to page 8.)
	The idling time from when the clutch started operating was too short.	Make the idling time longer. (Refer to page 10.)
	Flaring pressure is diminished.	Ask for inspection or repairs. (Refer to page 12.)
Flaws other than ring-shaped ones (vertical flaws, dents, etc.) occur on the flared inner surface of the tube.	Flaws were made while removing burrs on the inner surface of the tube.	Remove the burrs without making any flaws on the inner surface of the tube. (Refer to page 3.)
	Dust or metal chips adhered to the flare cone or the inner surface of the tube.	Remove dust and metal chips. (Refer to page 8.)
	Flaring pressure is diminished.	Ask for inspection or repairs. (Refer to page 12.)
A larger step (0.3 mm or more) occurs on the flared exterior surface of the tube.	The liner was attached in a stepped way.	Attach the liner without steps. (Refer to page 9.)
	There was a step (0.3 mm or more) on the clamp surface where the liner was to be installed.	Ask for inspection or repairs. (Refer to page 12.)
The flaring tool does not operate even when the switch is turned ON.	The battery has run out.	Recharge the battery. (Refer to page 7.)
	There are insulators, such as dust, between the battery and the conductive part of the flaring tool.	Remove the insulators.
	The wiring or the motor is faulty.	Ask for inspection or repairs. (Refer to page 12.)
The red charging lamp on the charger does not light up. (Charging is not possible.)	There are insulators, such as dust, between the battery and the conductive part of the flaring tool.	Remove the insulators.
	The wiring or the motor is faulty.	Ask for inspection or repairs. (Refer to page 12.)
	The temperature of the charger is too high.	Cool the charger and then recharge the battery. (Refer to page 7.)

Special Accessories

(1) Clamp (Fig.22)

Part No.424950

Although it is possible to cope with different tube sizes by replacing just the liner with an appropriate one, we recommend you flaring 5/8 or 3/4 diameter copper tubes using a clamp with a suitable liner as one set.

(2) Liners for tubes 5/8 and 3/4in diameter (Fig. 23)

(same as the conventional ones.)

These liners are used for 5/8 and 3/4 copper tubes, respectively.

purchasing a liner together with a clamp as a set saves labor when replacing liners.

(3) Lithium battery (Fig.24)

Part No.424955

For your convenience, keep a spare battery.

No other manufacturer's battery can be used.

(4) Charger (Fig.25)

Part No.424960

No other manufacturer's charger can be used.

(5) Carrying case (Fig.26)

Part No.424957

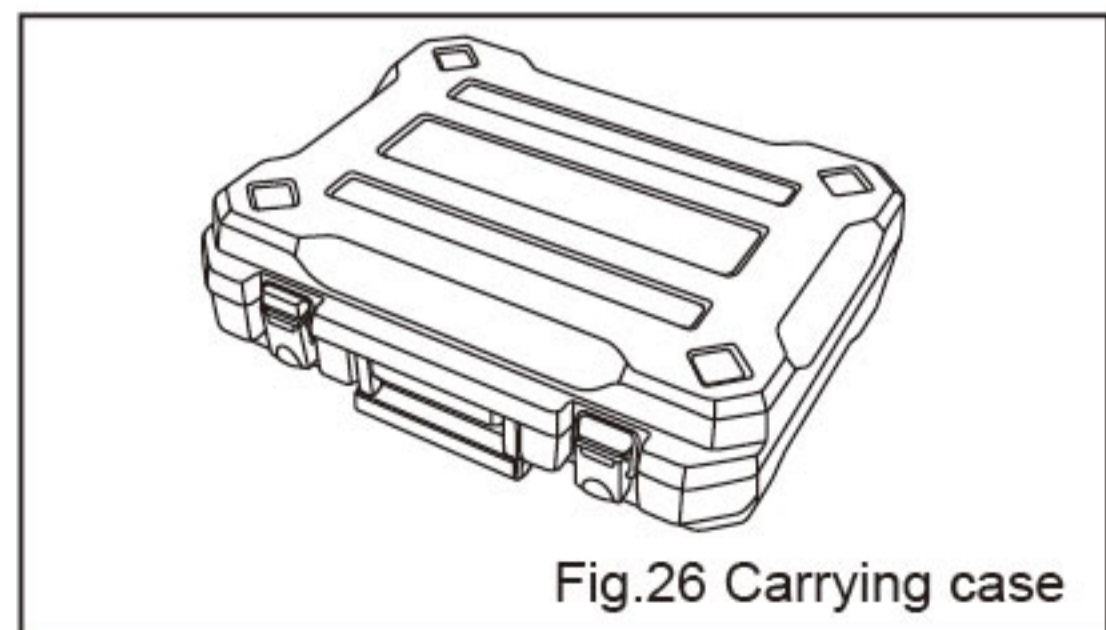
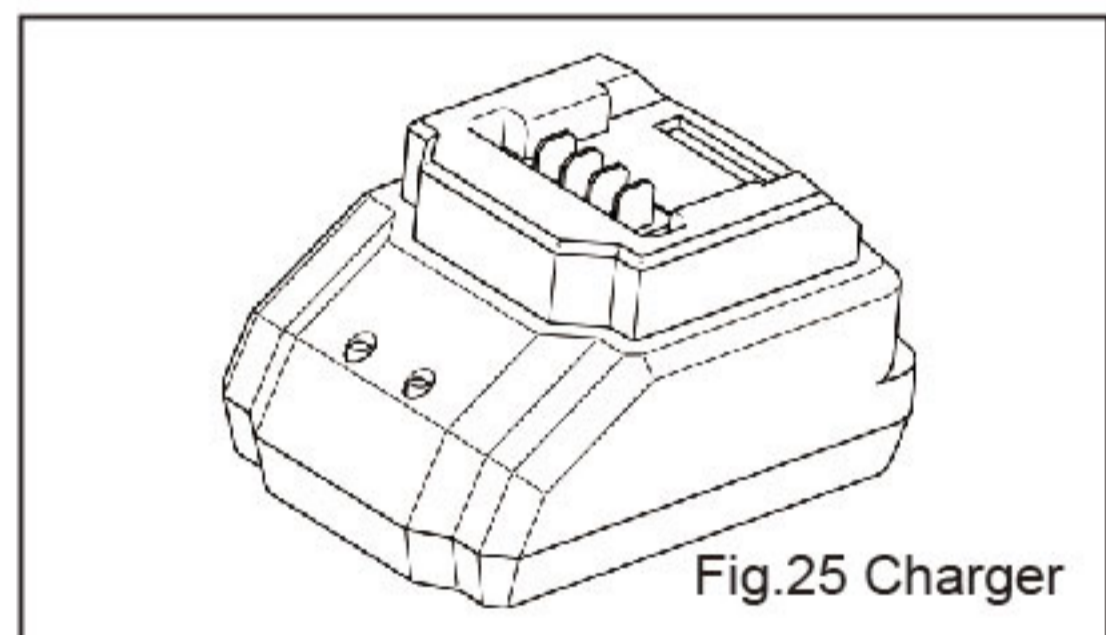
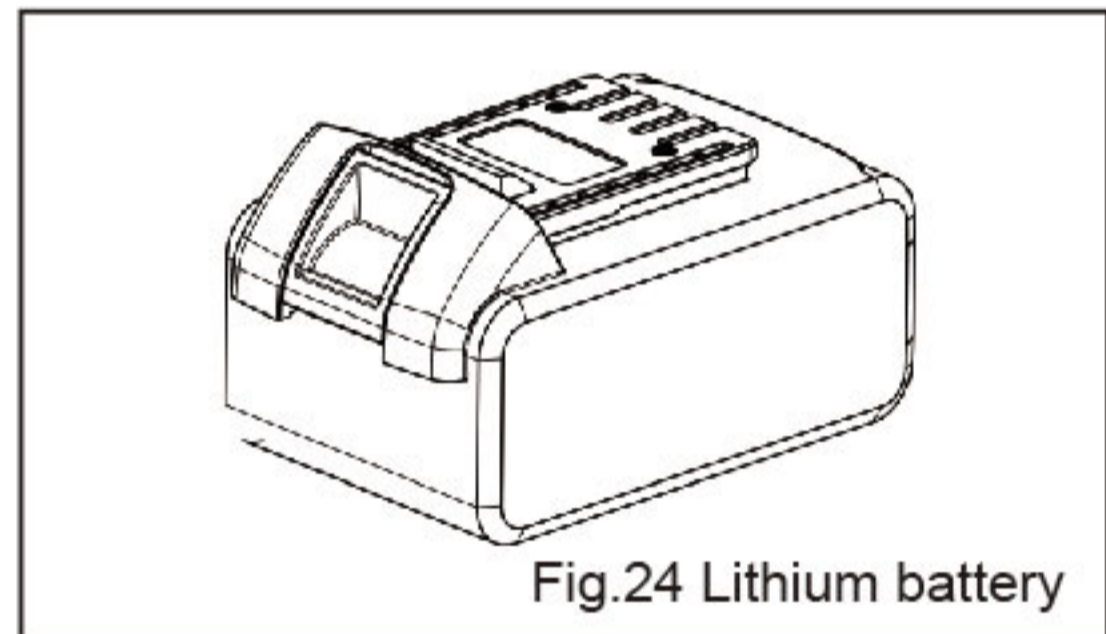
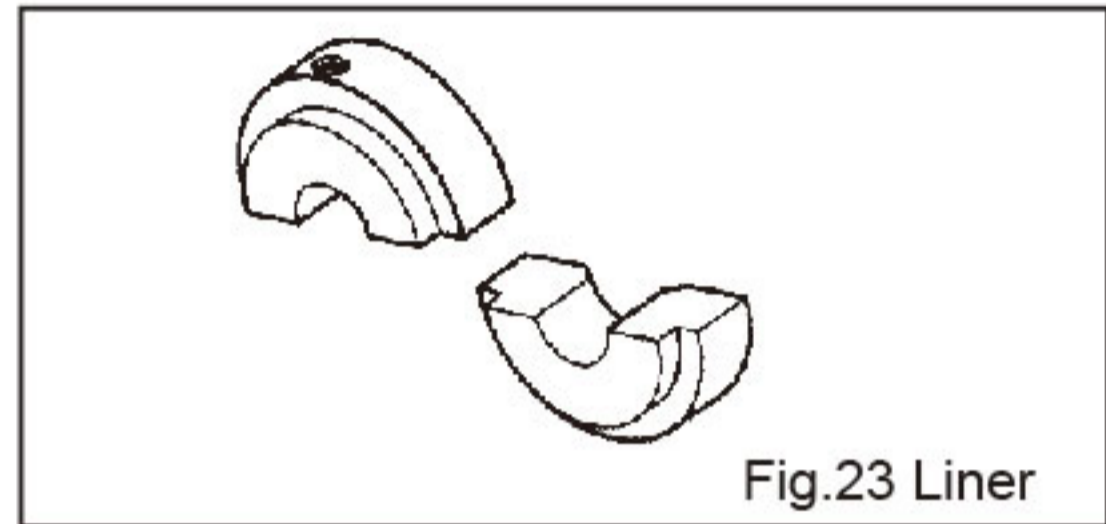
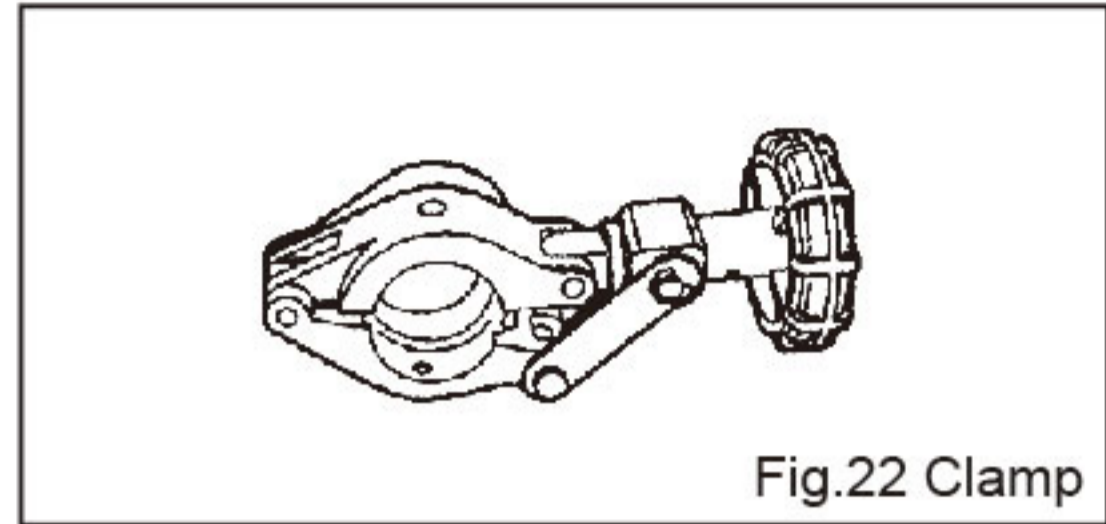



DSZH[®]

