

V4600/V8600E,T

COMPACT GAS CONTROL WITH THROTTLE VALVE

INSTRUCTION SHEET

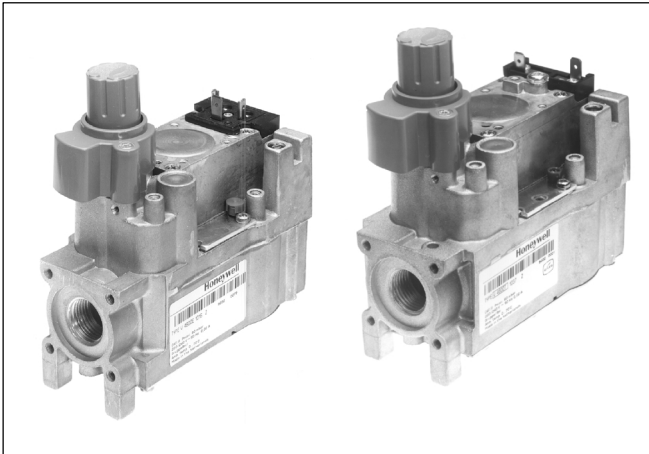

APPLICATION

V4600/V8600E,T gas controls, together with Honeywell pilot burner/thermocouple and room/boiler thermostats, provide all the functions necessary to safely regulate gas flow pilot burner and main burner manifold of domestic heating boilers (free standing and wall mounted), warm air furnaces and back boilers.

V4600/V8600E,T gas controls are intended to be used for manufactured, natural and LP gases (1st, 2nd, 3rd family gas).

V4600/V8600E,T gas controls are approved in accordance with existing european standards.

DESCRIPTION

V4600/V8600E,T gas controls comprise a pilotstat mechanism, throttle valve and an electric operated on/off valve.

The pilotstat is a thermoelectric safety device according to european standards EN 125 and EN 126 and closes off the gas supply to both main burner and pilot burner.

The electric on/off servo operator is an automatic shut-off valve of class J according to EN 161 and closes off the gas supply to the main burner.

SPECIFICATIONS

Models

V4600 serie: 220/240 V, 50 Hz.

V8600 serie: 24 V, 50 Hz.

Suffix E: fast opening and throttle valve

Suffix T: slow opening and throttle valve

Dimensions

See fig. 1.

Ambient temperature

0 ... 70 °C

Pipe connection

Pipe connections are designed to meet the bending stress of group 2 according to EN 161.

Standard:

Inlet: 1/2" ISO 7-1 internal parallel pipe thread.

Outlet: 1/2" ISO 7-1 internal parallel pipe thread or Ø18.6 mm without thread.

Inlet and outlet can also be made with straight or elbow flanges.

Special connection: Side outlet Ø14 mm

Pilot gas connection

Standard at end outlet: 1/4", 4 mm or 6 mm outer diameter tubing.

Special connection: Included in the side outlet.

Capacity*

In m³/h air at ΔP of 2.5 mbar.

Pipe connection	Capacity
1/2" x 1/2"	3.15
1/2" x Ø18.6 mm	3.15
1/2" x Ø14 mm side outlet	2.2

* Capacity curves are available on request.

Minimum differential pressure

Between inlet and outlet: 2.5 mbar

Minimum adjustable capacity

1.5 m³/h air at ΔP of 20 mbar

Maximum operating pressure

The P_{max} indication on the housing of the gas control is the maximum inlet pressure at which the gas control functions safely.

Mounting holes

Two M5 mounting holes are located on the bottom of the gas control.

The four holes at inlet and outlet for mounting the flange on the gas control are provided with M5 thread with minimum 6.5 mm full thread.

The four holes for mounting the flange to the side outlet are provided with M4 thread with min 6 mm full thread.

Mounting position

The gas control can be mounted 0 to 90° in any direction from the upright position i.e. from the position when the knob is on top.

Main gas connection

- Take care that dirt cannot enter the gas control during handling.
- Use a clean taper fitting with thread according to BS 21 or a piece of new, properly reamed pipe, free from swarf.
- Do not tighten the pipe or pipe fitting too far (see table below). Otherwise valve distortion and malfunction could result.

Pipe size	Max. length of pipe thread
1/2"	18.6 mm

- Apply a moderate amount of good quality thread compound to the pipe or fitting only, leaving the two end threads bare. PTFE tape may be used as an alternative.
- Ensure the gas flows in the same direction as the arrow on the bottom of the gas control.

Pilot gas connection

- Square off the end of tubing and remove burrs.
- Slip compression fitting over tubing.
- Insert tubing into gas control housing until it bottoms, slide fitting into place and turn finger tight.
- Use a wrench to tighten fitting about 3/4 turn beyond finger tight to make a pressure tight joint. **Do not use jointing compound.**
- Connect other end of tubing to pilot burner according to the pilot burner manufacturer's instructions.



CAUTION

Do not bend tubing at gas control after compression fitting has been tightened, as this may result in gas leakage at the connection.

Thermocouple connection

The gas control has an electrical thermocouple connection and must therefore be kept clean and dry; thread compound should never be applied to it. Tighten only 1/4 turn beyond finger tight in order to give good electrical connection. When routing the thermocouple tubing, do not bend it too sharply (min. radius 2.5 mm).

Perform gas leak test



WARNING

FIRE OR EXPLOSION HAZARD CAN CAUSE PROPERTY DAMAGE, SEVERE INJURY OR DEATH

Check for gas leaks with a rich soap and water solution any time work is done on a gas control.

Gas leak test

- Paint all pipe connections upstream of the gas control with with a rich soap and water solution. Bubbles indicate a gas leak.
- If a gas leak is detected, tighten the pipe connection.
- Stand clear while lighting the main burner to prevent injury caused from hidden gas leaks, which could cause flashback in the appliance vestibule. Light the main burner.

- With the main burner in operation, paint all pipe joints (including adapters) and gas control inlet and outlet with with a rich soap and water solution an approved leak detection fluid.
- If another gas leak is detected, tighten adapter screws, joints and pipe connections.
- Replace the part if gas leak can not be stopped.



CAUTION

Keep soap and water solution away from electrical connections.

Electrical connection



CAUTION

Switch off power supply before making electrical connections.

Take care that wiring is in accordance with local regulations.

Follow the instructions supplied by the appliance manufacturer. If there are no such instructions, see fig. 2. and 3. for typical wiring diagrams.

Use lead wire which can withstand 105 °C ambient.

The electric on/off servo operator is provided with:

both 6.3 mm terminals suitable for 6.3 mm receptacles (e.g. "Series 250" AMP fasteners) and screw terminals,

or provided with:

quick connect terminals suitable for 6.3 mm receptacles (e.g. "Series 250" AMP fasteners) or for a female connector according DIN 43650.

Wiring 220/240 V, 50 Hz (see fig. 2.)

Install the line voltage thermostat (or controller) and other controls as required.

Provide hard PVC boots on the AMP terminals to prevent touching of live terminals. When fitting a cover a Heyco-type strain relief should be used.

Wiring 24 V, 50 Hz (see fig. 3.)

Install the transformer, low voltage thermostat and other controls as required.

Adjust heat anticipator to the A rating as stamped on the gas control.

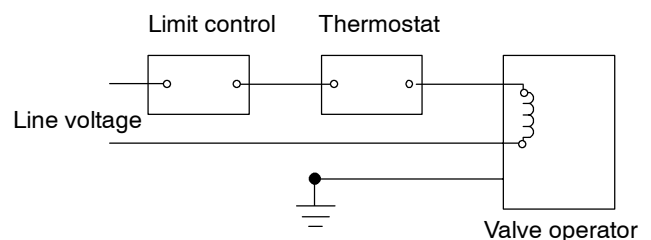

Fig. 2. Wiring 220/240 V, 50 Hz

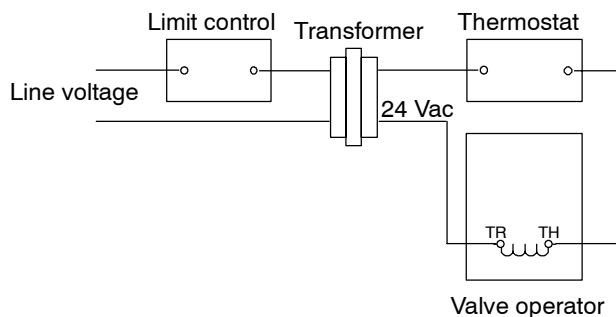

Fig. 3. Wiring 24 V, 50 Hz

OPERATION

The operation of the pilot safety system is accomplished by manipulation of a knob, provided with programming symbols that indicate lighting and shut off.

Lighting

- Depress knob and hold it down.
- Ignite pilot burner.
- Hold knob down for 20 seconds, after pilot burner has been lit.
- Release knob.
- Wait at least three minutes before a second attempt to light the pilot burner is made, when pilot flame has not been established.

Shut off

In order to interrupt all gas flow through the gas control, knob must be turned clockwise to its stop. After release the knob will automatically rotate to its ready position.

IMPORTANT

A safety latching device prevents the knob from being fully depressed until the thermocouple has cooled down sufficiently to de-energize the power unit, after which the knob will be effective again.

When the knob is depressed during latch position, pilot gas will flow to pilot burner. However, when knob is released, pilot gas extinguishes and main gas supply is not affected.

Wait one minute after shut off before starting lighting procedure.

ADJUSTMENTS AND CHECKOUT



WARNING

Adjustments must be made by qualified persons only. If the appliance manufacturer supplies checkout and/or service and maintenance instructions carefully

follow them. If these instructions are not provided then use the procedure outlined below.



CAUTION

To ensure a safe closing of the valve, it is essential that voltage over the terminals of electric on/off servo operator is reduced to 0 Volt.

Pressure tap

The gas control is provided with a pressure tap of 9 mm outer diameter at inlet and outlet side.

When checking the pressure undo the screw a half turn and slip tube over nipple.

Ensure that screw is retightened after making test.

Pilot flame adjustment (see fig. 1.)

The gas control is packed for shipment with pilot flow at maximum. Refer to the pilot burner manufacturer's instructions for recommended size of pilot flame.

If adjustment is required turn pilot flow adjustment screw clockwise to decrease or counter clockwise to increase pilot flame.

Outlet pressure adjustment (see fig. 1.)

- Energize electric on/off servo operator in order to have gas input to burner.
- Check input to the appliance using a clocking gas meter or alternatively a pressure gauge connected to the outlet pressure tap.
- Open cap to expose throttle adjustment screw.
- Turn the flow adjustment screw with a screw driver **either way** until the burner pressure required is recorded on the pressure gauge.
- Close cap.

Check of slow opening (softlite)

The softlite pressure is factory set.

Check burner performance at this pressure observing burner ignition and flame characteristics.

Burner should ignite promptly and without flash back to orifice and all ports should remain lit.

Cycle burner several times (wait 10 seconds between cycles to allow servo system to resume slow open action).

Repeat check of slow opening after allowing the appliance to cool down.

Checkout

Set appliance in operation after any adjustment and observe several complete cycles to ensure that all burner components function correctly.

Maintenance and service

Under normal circumstances no maintenance or service is required.

Screws on the valve that have been sealed must never be removed.